

711 OGDEN AVENUE
LISLE, ILLINOIS 60532

Where the Machines of Tomorrow are Made Today™

LOCKFORMER

OPERATING INSTRUCTIONS AND PARTS LIST FOR LOCKFORMER BAND SAW MODEL 24-S

NEO
WHEEL
TYRE # 171170



CAUTION: Before operating your new Lockformer Saw read instructions carefully to be sure that both proper blade speed and blade type are correct for the material to be worked. Table 1 explains blade selection and speed. Table 2 gives stack cutting recommendations, and Table 3 explains blade pitch with reference to radius cutting.

Proper machine set-up is shown in Fig. 1 2 & 3 with accompanying text. Figures 4 & 5 with text, explain various adjustments.

Blade life as well as cutting efficiency is dependent upon proper blade selection and speed, so recommendations, given herein should be followed closely. Your Lockformer Bett Marr is a precision cutting tool and, with proper care, will give many years of trouble-free, efficient service.

LOCKFORMER

Where the Machines of Tomorrow are Made Today™

711 OGDEN AVENUE
LISLE, ILLINOIS 60532

ASSEMBLY AND ADJUSTMENT PROCEDURE

ADJUSTMENT TAKE-UP

The reduction unit is mounted on an eccentric hub and bearing assembly 44002 (see Figure 1) that can be revolved to the right slightly to take up any undue slack in the drive chain and V-belt.

MOTOR BELT INSTRUCTION

Motor belt can be tightened by turning hand wheel on base to the left. **DO NOT** have belt too tight.

ASSEMBLY OF TABLE ON SAW

First, remove the table slot screw from the table. (See Figure 5.) Guide the blade through the slit in the front edge of the table 50269 and then rest the two front table lugs on the 3/4" round table mounting shaft 13012. At the same time slip the rear table lug over the 3/8" table mounting pin 60763 in the frame until the lug contacts the frame. Finally, lock the front lugs to the mounting shaft with the two 1-1/4" long studs and washers 60002. Screw the table slot screw into the front edge of the table.

The insert riser bar 9956554 is fastened to the top of the table when cutting stacked galvanized or stacked aluminum sheets.

UPPER WHEEL ADJUSTMENT AND TRACKING THE BLADE

Place the blade on the rubber tires of both the upper and lower wheels and shift the back edge of the blade up against the flange of both wheels, then, increase the tension on the blade by screwing the riser bolt 52605 to the right (see Figure 4.) Care should be

taken that the tension is not too great to interfere with free movement of the wheels. Too great a tension on the blade is a common cause of blade breakage. When tension has been adjusted, revolve the wheels slowly forward by hand. **NEVER ADJUST ANY PART OF THE SAW WHILE MOTOR IS RUNNING.** If the blade creeps away from the flange on the upper wheel, tilt the upper wheel in at the top slightly by turning the upper wheel bracket adjusting bolt 60525 to the right. This will cause the blade to gradually creep up against the flanges, in which position the blade is tracking properly. Lock the adjusting nut in place to prevent shifting during operation of the saw.

SETTING AND ADJUSTING THE BLADE GUIDES

After the blade has been "tracked" properly, the blade guide brackets 40380 (Upper) and 40381 (Lower) in Figure 5 should be adjusted so that the slit in the carbide thrust and blade guides 85101 Upper and Lower are parallel and centered with the blade. Also, when centering the blade guides, adjust the carbide thrust and blade guide 85101 Upper and Lower in or out, so that the back of the blade clears the back of the slot in the carbide guides by about 1/64"

The blade should run freely through both the blade guides when the blade guides are adjusted properly. Finally, lock the carbide guides into position by tightening the Allen setscrew in the guide insert holders.

NOTE: The carbide thrust guides furnished with the saw are for 1/4" and 3/8" blades. The carbide guides are reversible, one side is for 1/4", the reverse side is 3/8". Make sure that proper slots are used on upper and lower. Teeth **MUST** project outside of carbide insert. Carbide guides may also be purchased for 3/16" and 1/2" blades.

ATTACHMENTS AVAILABLE

30° Angle Guides

#350402

1/4"-1/4" Carbide

Inserts

#85103

3/16"-1/2" Carbide

Inserts

#85107

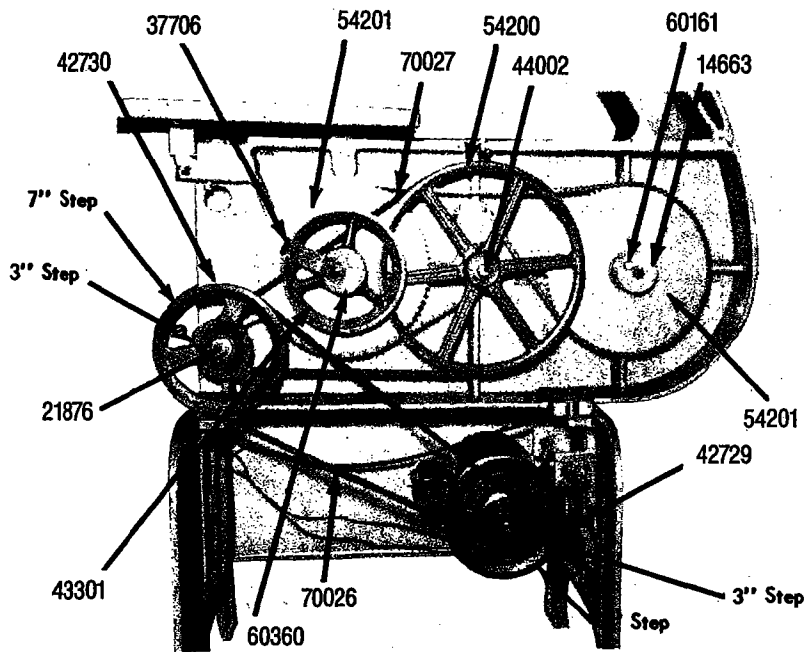

Fig. 1

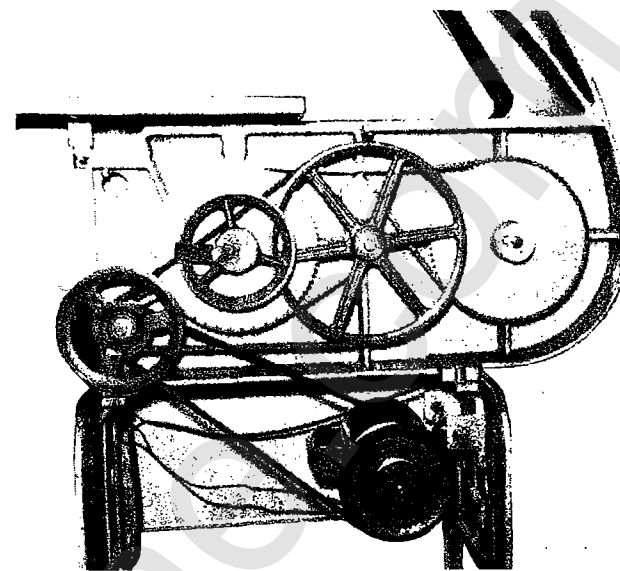

Fig. 2

FOR 100 FEET PER MINUTE BLADE SPEED—

The two Allen socket head cap screws are engaged, 60360 is engaged in the 10" sprocket 54201 and the shaft locking hub of the 7" pulley 43301 the second cap screw 60161 is engaged in keyed drive collar 14663 and the rear 10" sprocket 54201. Note warning tag 37706 is on hub of 7" pulley. (See Figure 1). The 54" V-Belt 70026 is placed on the 7" groove of the step idler pulley 42730 and the 3" step groove of the motor drive pulley 42729. Turn on switch and you will operate at 100 F.P.M.

FOR 600 FEET PER MINUTE BLADE SPEED—

The two Allen socket head cap screws are engaged, 60360 is engaged in the 10" sprocket 54201 and the shaft locking hub of the 7" pulley 43301 the second cap screw 60161 is engaged in keyed drive collar 14663 and the rear 10" sprocket 54201. Note warning tag 37706 is on hub of 7" pulley. (See Figure 2). The 54" V-Belt 70026 is placed on the 3" groove of the step idler pulley 42730 on the 7" step groove of the motor drive pulley 42729. Turn on switch and you will operate at 600 F.P.M.

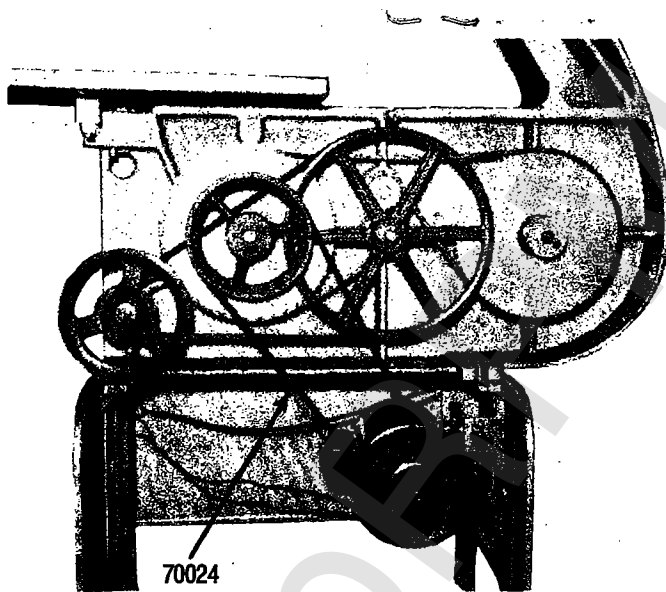

Fig. 3

FOR 3000 FEET PER MINUTE BLADE SPEED—

Remove the two Allen socket head cap screws 60360 and 60161 and warning tag 37706 from the 10" sprocket 54201 and the shaft locking hub of the 7" pulley 43301 and from the keyed drive collar 14663 and the rear 10" sprocket 54201 (See Figure 3). This disengages the speed reduction unit from the band saw drive shaft. It is imperative that these cap screws be removed before operating at 3000 F.P.M. Remove 54" V-belt 70026 completely from the machine.

The 51" V-Belt 70024 (this belt is furnished with the machine and is packed separately) is placed on the 3" step groove of the motor drive pulley 42729 and the 7" pulley 43301. Turn on switch and you will operate at 3000 F.P.M.

NOTE: The 56" V-Belt 70027 that connects the 12" pulley 54200 with the second 2-3/4" groove of the 7" step idler pulley 42730 remains engaged on this assembly during all speed changes.

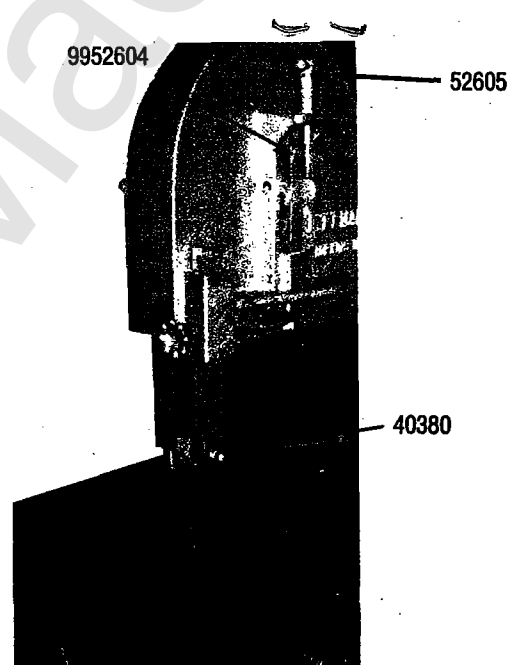

Fig. 4

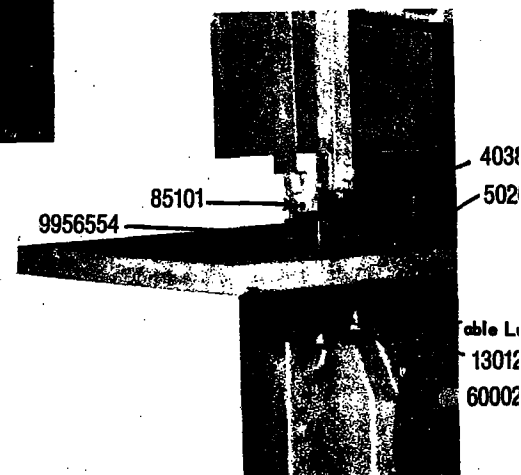

Fig. 5

Band Saw

12" Pulley, Bearing and Eccentric Assembly (54204)

Components

12" Pulley and 2" Sprocket Assembly P/N - 54200
Bearing and Shaft Assembly P/N - 44002
Eccentric P/N - 19133

Assembly Instructions

1. Place pulley and sprocket assembly (54200) with sprocket side up on bench in a position where, when bearing is pressed in, it can protrude from the back without interference.
2. Press bearing/shaft assembly, slotted end first, so that the bearing sticks out approximately 1/4."

NOTE: Be sure to press bearing from outside diameter of bearing by using a spacer or something comparable, or damage may result!

3. Place pulley on bench where slotted end of shaft and bearing is supported on bench. Now press eccentric on bearing-shaft (opposite slotted end) to achieve an approximate 1/16" clearance between end of eccentric and end of bearing.

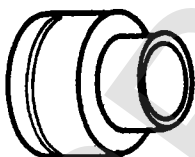
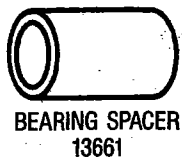
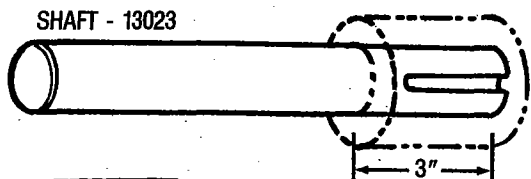
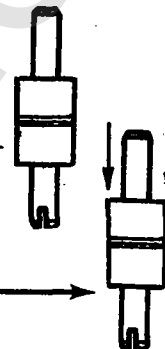
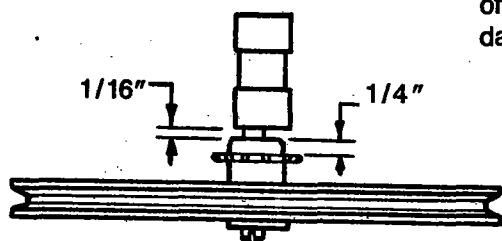
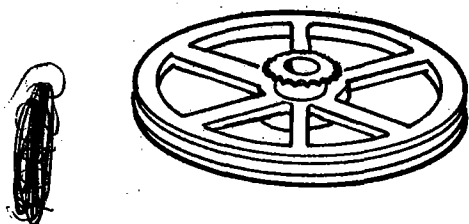

BEARING
66502 (2)

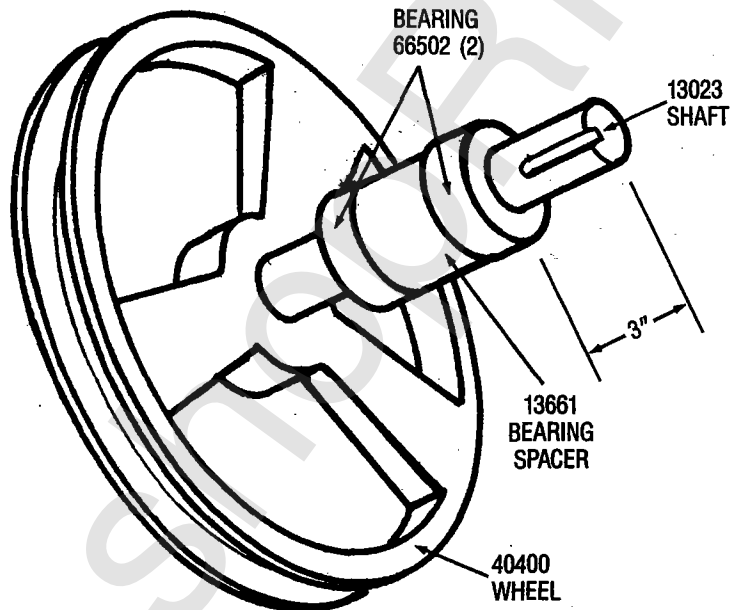

Band Saw

12" Sprocket Assembly

Assembly Instructions

1. Insert shaft in 3" spacer or 3" into vise - key way side down.
2. Press on bearing (66502) - hub side up.
3. Insert bearing spacer (13661).

4. Press on bearing (66502) hub side down.

NOTE: Be sure hubs from bearings are inside bearing spacer.

5. Press on wheel (40400) hub side out - so that hub end is flush with shaft end.
6. Slide whole assembly into frame casting.
7. Slide on 10" sprocket (54201) from other side.
8. Slide on keyed drive collar (14663) and lock down with set screw.

TABLE 2**Stack-Cutting Recommendations**

GALVANIZED SHEETS:	26 gauge, stack 1 to 50 sheets	600 F.P.M.
SHEET STEEL:	Hot roll, cold roll, and any other metal than galvanized, stack 1 to 10 sheets.	100 F.P.M.
COLD ROLL, SHEET STEEL, ALUMINUM COATED:	Stack 1 to 10 sheets, cut at lowest speed	100 F.P.M.
ALUMINUM SHEETS:	Stack 15 to 30 or more, use 4 pitch blade. Single sheets use 24 pitch blade. Lubricate scribe line with bees wax or cutting oil to aid in the lubrication of cutting teeth.	600 F.P.M.
STAINLESS SHEET STEEL:	FRICITION CUT, use 14 or 24 pitch blade, dull or sharp. CUT SINGLE SHEETS ONLY UP TO 12 GAUGE.	3000 F.P.M. (Direct Drive)

For cutting thin sheets use a fine pitched blade with at least three teeth engaged in the work at all times. If the teeth "come out of the work" they will tear out and the blade ruined. Generally, thick stock requires larger teeth and a slower cutting speed than thin stock.

TABLE 3**Radius Cutting Recommendations**

SAW WIDTH	SMALLEST RADIUS CUT
1/8 in.	1/8 in.
3/16 in.	5/16 in.
1/4 in.	5/8 in.
3/8 in.	1 7/16 in.
1/2 in.	2 1/2 in.

Avoid twisting blade. Use gradual, constant pressure in feed of work into blade with gradual radius of cut.

SIMPLE REMINDERS TO INSURE MAXIMUM BLADE LIFE

In most instances, experience has shown that shortened blade life results from the following:

1. Incorrect blade speed (with reference to material being cut)
2. Incorrect blade pitch (with reference to thickness of material or stacked material)
3. Blade being improperly set in guides
4. Excessive feed pressure or undue forcing of work into blade.

In addition to following the recommendations made herein, these additional general rules may be helpful:

FIRST: Since the blade travels from top to bottom, blade teeth should always be pointing downward.

SECOND: Keep at least three teeth in the work at all times. If you cut a thin piece of steel with a coarse tooth blade, you may rip off teeth or break the blade. In general, the thinner the material or the stack of material, the finer the blade tooth should be.

THIRD: Be sure the teeth of the blade clear the outside slot of the guide blocks.

TABLE 1

Speed and Tooth Recommendations

(Keep at least 3 teeth in work at all times!)

MATERIAL WORKED	PITCH	SPEED FT./MIN.	MATERIAL WORKED	PITCH	SPEED FT./MIN.
-----------------	-------	----------------	-----------------	-------	----------------

FERROUS METALS

Carbon Tool Steel	10 to 14	100	Mild Steel (not rolled)	10 to 14	100
Cast Iron	14	100	Nickel Silver	10 to 14	100
Cast Nickel Iron	10 to 14	100	Nickel Steel	10 to 14	100
Chromium Steel	10 to 14	100	Pipe	14 to 18	100
Cold Rolled Steel	10 to 14	100	Stainless Steel up to 12 gauge	10 to 14	3000
Drill Rod	10 to 14	100	Stainless Steel over 12 gauge	10 to 14	100
High Chrome Carbon Steel	10 to 14	100	Steel (structural)	10 to 14	100
High Speed Steel	10 to 14	100	Galvanized Sheet Steel	14 to 32	600
Iron Sheets	14 to 32	100	Tool Steel	10 to 14	100
Machine Steel	10 to 14	100	Tubing (steel)	14 to 18	100
Malleable Iron	10 to 14	100			
Manganese Steel	10 to 14	100			

NON FERROUS METALS

Aluminum Airplane Alloys	6 to 14	600	Brass, sheets (thin)	10 to 14	3000
Aluminum Castings	6 to 8	600	Brass tubing (thin)	10 to 14	3000
Aluminum, pure	6 to 8	600	Bronze Castings	8 to 14	600
Aluminum, single sheets	10 to 18	3000	Bronze, manganese	10 to 14	600
Aluminum sheets stacked	4 to 10	600	Bronze, government	10 to 14	600
Aluminum tubing	10 to 14	3000	Bronze, nickel	10 to 14	600
Babbitt (type & bearing metal)	6 to 10	600	Copper	10 to 18	600
Brass Castings	8 to 14	600	Copper, drawn	10 to 14	600
Brass, soft screw stock	10 to 18	600	Monel Metal	10 to 14	600
			Monel Sheets	14 to 24	600

PLASTIC and NON-METALLIC

Asbestos Board	8	600	Metal Wood	14	600
Asbestos Sheet	8 to 14	600	Mica	10 to 14	600
Bakelite (plastics)	8 to 18	600	Rubber, hard	8 to 10	600
Fibre	8 to 10	600	Wood	6 to 14	3000
Formica	8	600			

BAND SAW MODEL 24-S PARTS LIST

PART NO.	DESCRIPTION	PCS. PER UNIT	PART NO.	DESCRIPTION	PCS. PER UNIT	PART NO.	DESCRIPTION	PCS. PER UNIT
40330	Frame	1	*14663	Keyed Drive Collar	1	*14835	Stud	1
56549	Upper Front Cover	1	43211	Idler Chain Sprocket	1	14535	Hinge Pins	1
56550	Lower Front Cover	1	66041	Eccentric Idler Shaft Plug	1	24923	Lower Front Cover Spacer	1
*60984	Knurled Cover Studs	4	66063	Idler Oilite Bearing	1	29306	End Plate Brace	2
*60550	1/4-20-1/2 RHMS Cad	6	13119	Idler Shaft	1	58641	Stand Assembly	1
40340	Upper Wheel	1	*62055	1/2 ID 1/16 Washer	1	*60051	5/16-18 X 2 HHCS	1
44003	Bearing	1	54200	12" Pulley & 2" Sprocket Assembly	1	*60052	5/16-18 X 1 HHCS	2
40350	Upper Wheel Bracket	1	70027	56" Belt	1	*60056	5/16-18 X 1-1/2 HHCS	6
14501	Upper Wheel Bracket Pin	1	*21876	Idler Holder	1	*60094	3/8-16 X 1-1/4" HHCS	1
40360	Riser Bar	1	42730	3 Step Pulley	1	*60153	1/2-12 X 1-1/2" HHCS	1
*60525	5/16-18-3/4 Flat Head Cap Screw	1	44001	Ball Bearing	1	*60161	1/2-13 X 3-1/4 HHCS	1
21878	Wheel Riser Bar	1	50269	20 X 22 Table	1	*60576	10-24 X 1/2 RHMS	1
52605	Riser Tension Bolt & Crank	1	*60002	1/4-20 1 HHCS	2	*60652	5/16-18 X 1/2 SSS	5
13514	Riser Bolt Spacer	1	*60763	5/16-18 2 Sq. Head Set Screw	1	*60795	4 X 3/16 DR SCR TP-U	4
71170	Neoprene Wheel Tire	3	*60054	5/16-18 1 HHCS Cad	2	*61040	10-24 HN	1
9956505	Riser Bar & Blade Guard (21802)	1	13012	3/4 Table Support Shaft	1	*61122	3/8-16 HN	2
*35701	Blade Guard	1	39930	Table Blade Insert	1	*62010	5/16 X 1/16 Washer	4
*60790	2 1/4 Drive Screw U Cad	2	9956554	Insert Riser Bar	1	*62029	3/8 X 1/16 Washer	2
40380	Blade Guide Bracket	1	40420	Stacking Clamps	4	*62362	5/16 Lock Washer	4
*60610	1/4-20-1/4 SSS	3	60923	5/16-18 2 Clamp Thumb	4	*62362	3/8 Lock Washer Med.	2
*60055	5/16-18 X 5/8 HHCS	2	80030	3/4 HP Motor 1800	1	*80543	Cord 18-2 8-4	1
21651	Guide Insert Holder	2	*42729	7 X 3 Step Pulley	1	*80602	Rg Tng Terminal	3
*60593	7/16 X 10-32 Fillister Head Set Screw	2	*31425	Motor Mounting Plate	1	*80607	Insulating Cap	3
85101	3/8 X 1/4 Carbide Guide	2	70026	54" Belt	1	*80608	Wire Joint	3
52604	Riser Bar Locking Bolt & Wheel	1	70024	50" Belt High Speed	1	*80703	Toggle Switch Plate	1
56506	Blade Oiler Assembly	1	52600	Motor Adjustment Bolt Assembly	1	*85004	Blade 118" Ig.	1
66710	Felt Oiler Pad	1	*61120	3/8-16 HN HVY SF	2	*85155	Band Saw Name Plate	1
40381	Blade Guide Bracket (Lower)	1	80206	Toggle Switch	1	*85178	Lockformer Logo	1
40400	Lower Wheel	2	80545	6' Cord and Plug Set	1	*85303	Warning Sticker	2
*21879	Riser Bar	1	*80702	Flex Tube	1	66412	Bushings	2
66502	Sealed Ball Bearing	4	*80540	Cord	1	62612	1/4 X 3/4 Dowel Pin	1
*13023	Lower Wheel Bearing Shaft	2	*80210	Toggle Switch Bdy	1			
*13661	Bearing Spacer	2	*80700	Half Reflector	1			
62423	Shaft Key	2	*80701	Steel Clamp	5			
*54201	10" Sprocket, Hub & Bearing Assembly	2	*60820	6-3/4 Drive Screw U	5			
43301	AC 70 Shv	1	56551	Belt Guard	1			
*60360	5/16-18 2 SHCS Cad	2	14803	Belt Guard Attaching Stud	1			
37706	Warning Belt Guard	1	*61475	5/16-18 Wing Nut	1			
73010	35 Roller Link Chain	205	*61101	5/16-18 HN HVY SF	10			
*70712	35 Conn Link <i>MASTIA</i>	1	62011	5/16 1/8 Washer	5			

*Not Illustrated

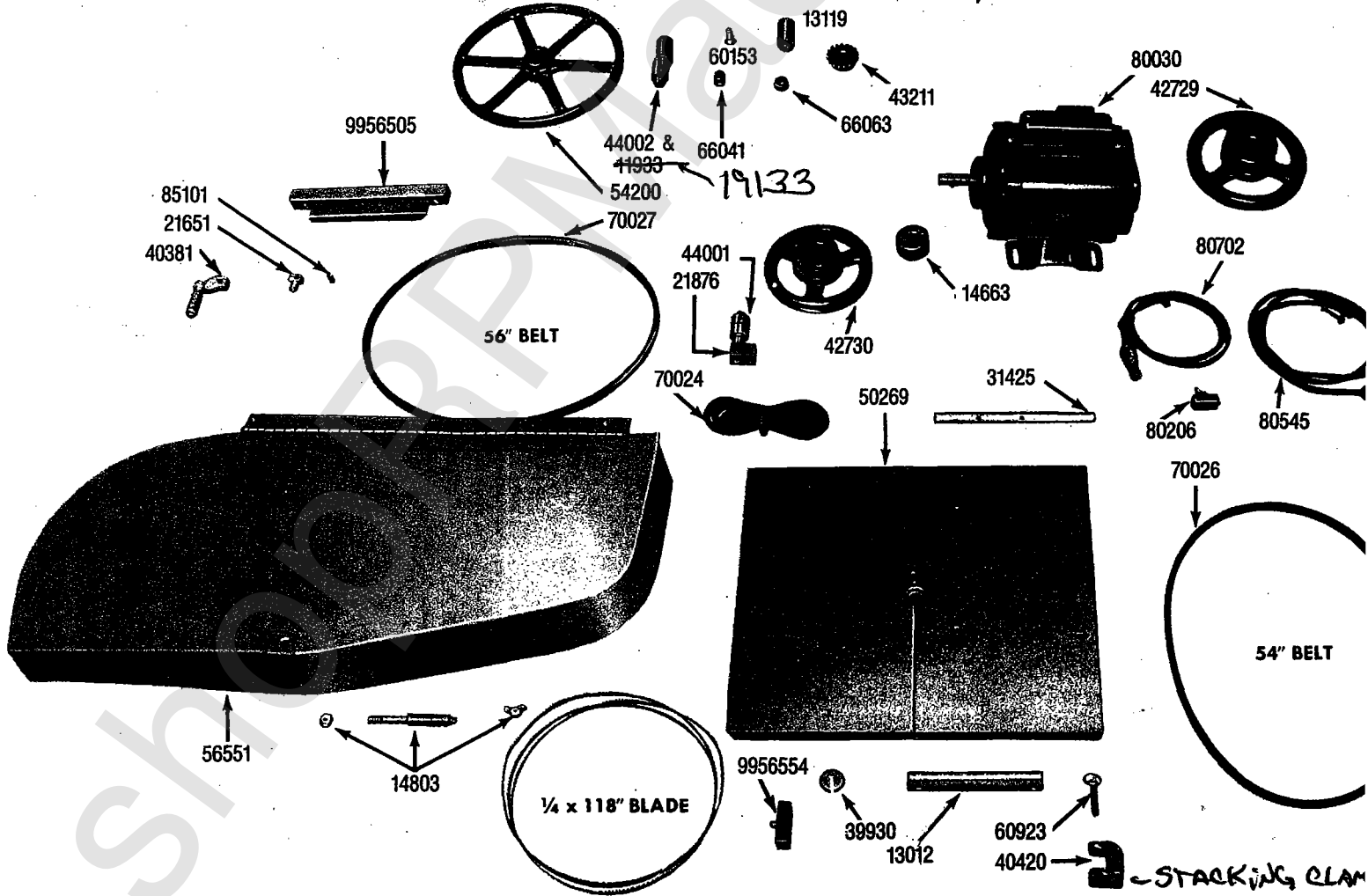
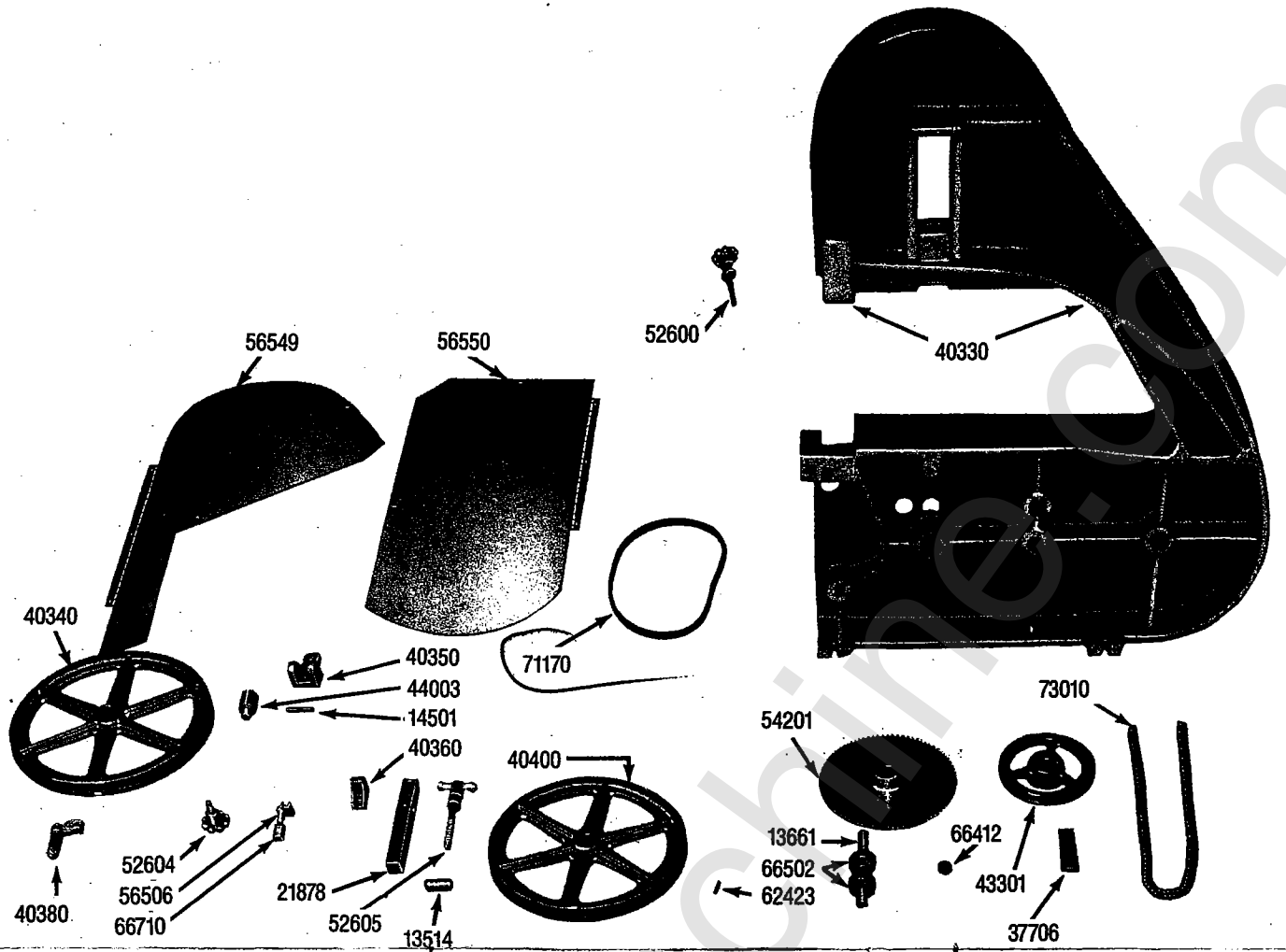

24-S BANDSAW

