

LOCKFORMER®

Button-Punch

SNAP LOCK

FLANGER

FOR 20 TO 28 GAUGE MATERIAL

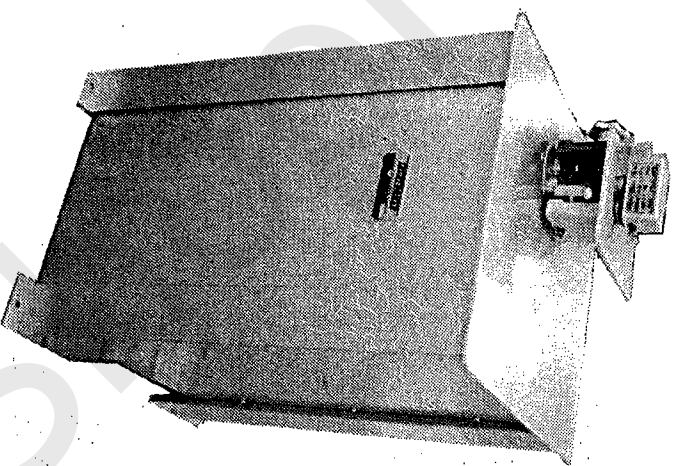

THE LOCKFORMER COMPANY
711 W. OGDEN AVENUE • LISLE, IL 60532

OPERATING INSTRUCTIONS FOR LOCKFORMER BUTTON PUNCH FLANGER

Capacity: 20 to 28 Gauge Galvanize

To satisfactorily form the 90° button punch flange on light gauge materials, it was necessary to form the metal in two stages.

Stage #1: To form the flange to the necessary height and
Stage #2: To introduce the button punch to the flange.

Operation Stage #1

(A) Adjust the Front Adjusting Screw (60983 on drawing) to the gauge material to be flanged. Note: An indicator punch mark is located on the end of the screw for reference. The reference mark will be on top when the adjusting screw is tight. To adjust tighten screw by hand.
See Sketch A)
Loosen screw required amount for the material being formed.

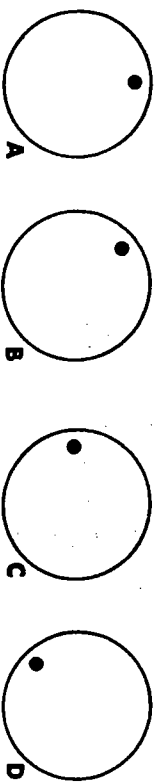

FRONT ADJUSTING SCREW SETTINGS

- *1/8 to 1/4 turn 26-28 Gauge "B"
- *1/4 to 3/8 turn 24 Gauge "C"
- *3/8 to 1/2 turn 22/20 Gauge "D"

*The above settings are approximate and will vary due to grades and type of galvanized sheets used. Practice and use will yield the exact setting for specific metals.

Important: Do not set front adjusting screw too tight. It should be set just tight enough to draw the metal through the rolls. Too tight of a setting will stretch and wrinkle the material or stall the machine.

(B) Adjust the Tension Screw (Hand Screw On Back Of Machine 14922). Tighten and loosen screw the required amount for material to be formed.

- 20 Gauge - 1 Turn Loose
- 22 Gauge - 1 Turn Loose
- 24 Gauge - 1 1/4 to 2 Turns Loose
- 26 Gauge - 3 Turns Loose
- 28 Gauge - 3 1/4 Turns Loose

(C) Turn Up A Starting Flange on the material before inserting it into the rolls. This is done by inserting the leading edge of the work to be flanged in the slot cut into the table and bending the piece away from the operator. It is most important to turn up a FULL 3/8 Flange at the beginning since this controls the height and also since button will not punch if flange is not at proper height. Start the material into the rolls on the lower stage of the machine.

As the material passes through the rolls, the compensator arm will make contact with the material and guide it through the rolls. If the material pulls out of the rolls it is an indication that either front adjusting screw is too loose or the back tension screw is not tight enough.

Important: Rated capacity of this machine is 20 to 28 Gauge galvanize. In running the lighter range of materials (26 to 28 gauge) it is most important that the back adjusting dial and front screw be at the proper settings. A wavy flange and an incorrect height will result if these instructions are not carefully followed. To adjust tool for 28 gauge screw front adjusting screw (thumb screw in lower unit 60983) tight and loosen 1/8 turn. Adjust the tension screw (hand screw on back of machine 14922) tight and loosen 3/4 turns.

Proper adjustments will result with a smooth regular flange. Too much pressure will create a buckled flange showing a heavy knurl marking on the flanged edge of the material. Insufficient pressure will cause the material to slip in the rolls and not be powered through the machine.

The buckled flange can also be caused by too much pressure being exerted by the pressure arm (40071). Consult settings on screws and adjust accordingly. A slight variance of the indicated readings may be required for various materials.

A buckled flange can be corrected by moving the compensator arm back to its lock out position. Then run flange through the rolls only. Do not apply any pressure to the material — but only support the piece as it goes through the machine. If the buckle is minor Stage Number 2 will remove it.

Operation Stage #2

Adjust the front adjusting screw (60983) on the upper stage same as for the lower stage.

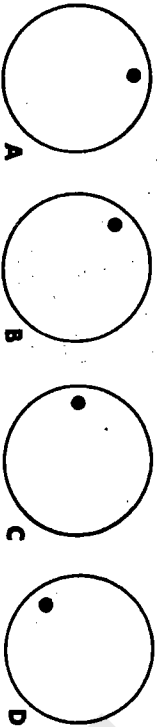

UPPER ADJUSTING SCREW SETTINGS

- 1/8 to 1/4 turn from tight "B" 26-28 Gauge
- 1/4 to 3/8 turn from tight "C" 24 Gauge
- 3/8 to 1/2 turn from tight "D" 22/20 Gauge

Run material through the upper section for punching operation.

To eliminate galvanize accumulation on knurled forming roll, it may be necessary from time to time to apply either kerosene or a light machine oil to the knurled roll. This will aid in keeping the roll from an over-deposit galvanized material. If galvanized material packs into knurl recesses, it is desirable to clean this part with a scraping tool or wire brush and then oil.

When running materials, other than cold roll steel or galvanized, e.g. aluminum stainless or copper, a slight modification of the standard settings may be required to operate properly.

For Running: Aluminum, Copper (soft) Materials:

The above materials will require a looser setting on both the front gauge (thickness) setting and pressure setting (spring pressure). Experience or test settings will be required. Should material shear at the corner, the damage could be caused by excessive pressure or metal pick-up and "galling" on the lifter button.

Where "galling" or metal pick-up is evident, the material will require lubrication to the part of the material being formed. Lubricants such as kerosene or a light machine oil should prove adequate.

For Running: Stainless Steel or Hard Brass Materials:

Increased spring pressure may be required for running certain types of stainless. A standard thickness setting is adequate. A drawing compound may be necessary to eliminate pick-up. A special aluminum bronze lifter button may be necessary for prolonged use of stainless materials. (A special quotation would be required for this button.)

It is very important that the body parts top and bottom be made to conform to the cheeks. The radius of the body may be over formed slightly to allow easier insertion of the cheek section. Note: If cheeks are continuous arcs, very little difficulty should be experienced. However, straight to curve (inside or outside) to straight will require care when forming the body so that the arc will be formed to the tangent of the radius. A plus or minus factor will cause difficulty in the final closing of the final elbow. Do not crush snap lock with pinch rolls when forming arcs. Allow adequate clearance between front rolls to pass lock through. There will be a certain amount of closing when forming by back (3rd) roll but not enough to affect snap. On small radius curves it is better to control formed curve by running larger diameter and then with hand pressure diminish radius with several passes through slip rolls.

BUTTON PUNCH FLANGER REPLACEMENT KIT #190103
 APPLIES TO ALL MACHINES WITH SERIAL NUMBERS BFF-1775 AND HIGHER

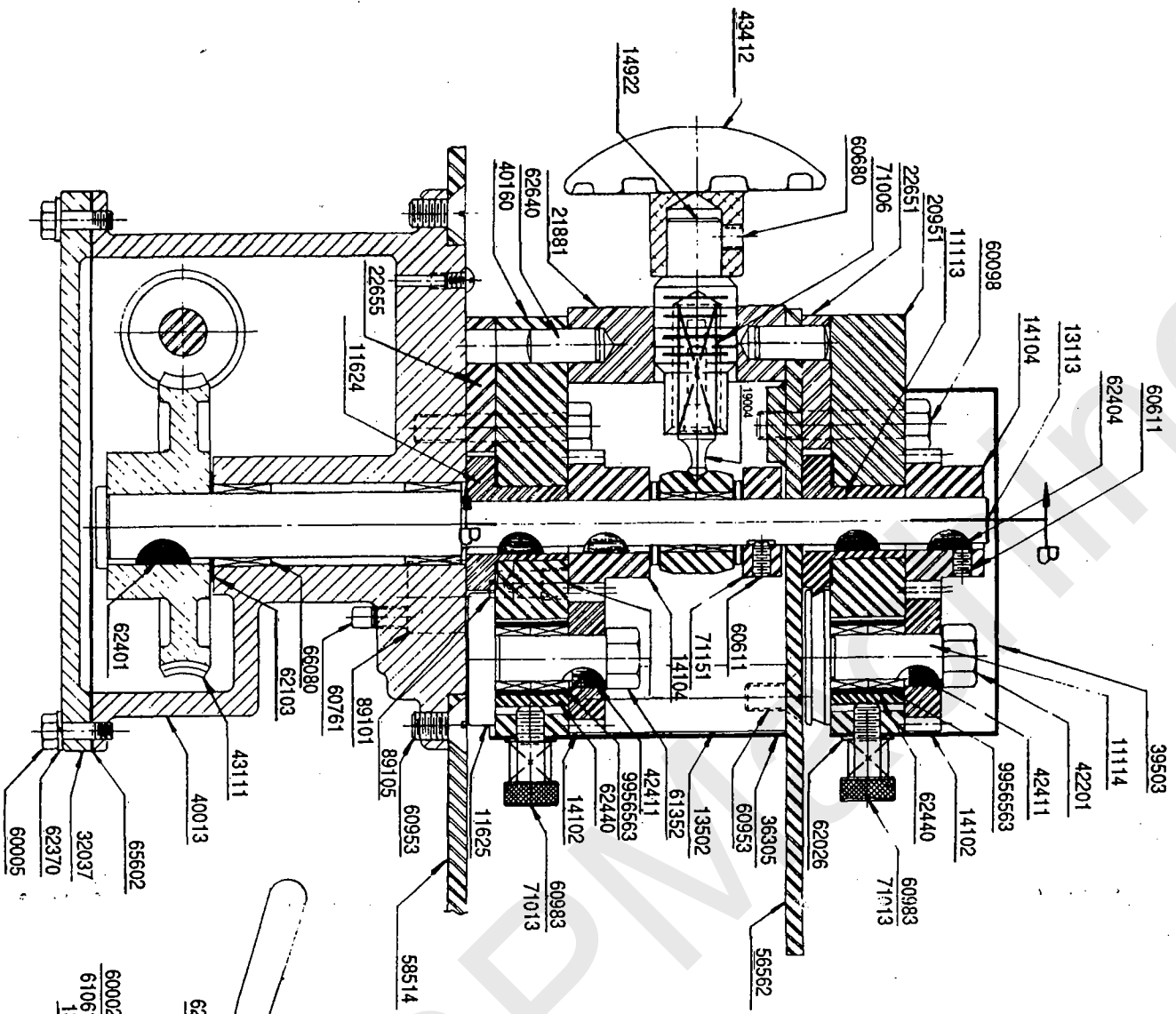

TO REPLACE PARTS: LOOSEN AND REMOVE NUT 42201 AND BOLT 60098. LOOSEN KEY SCREW 60611. REMOVE GEARS 14102 AND 14104. BLOCK 20951. REMOVE OLD SPACER PLATE, MALE AND FEMALE ROLLS. REPLACE NECESSARY PARTS AND ASSEMBLE IN REVERSE ORDER. REPLACEMENT PARTS:

MALE ROLL	11113
FEMALE ROLL	11114
SPACER	25512
GEAR	14104

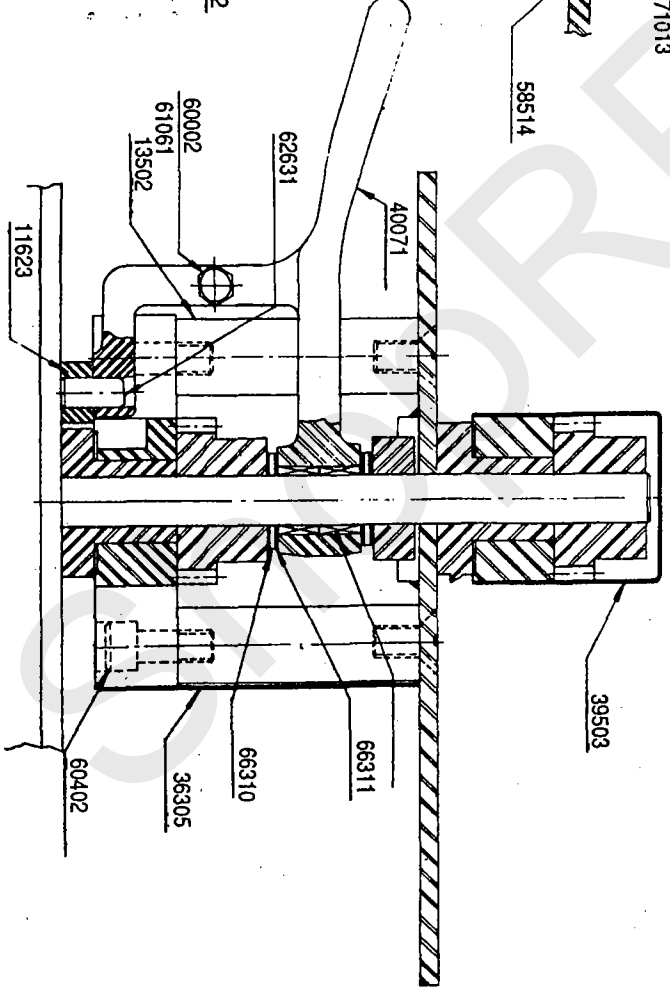
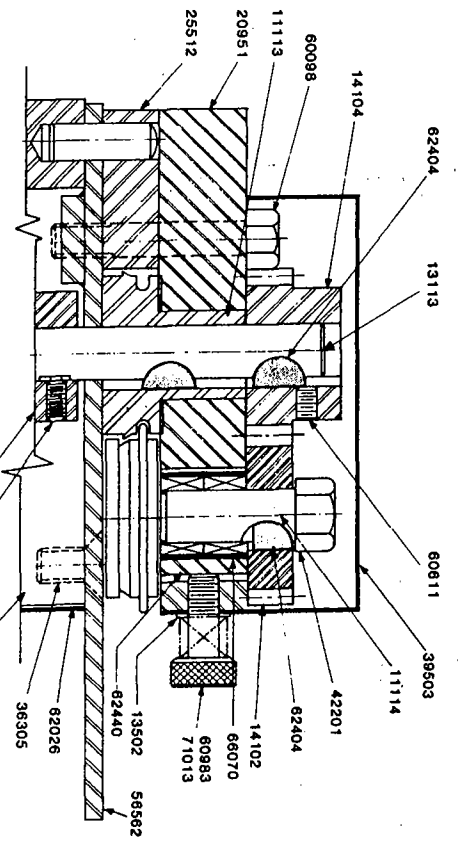

SECTION B-B

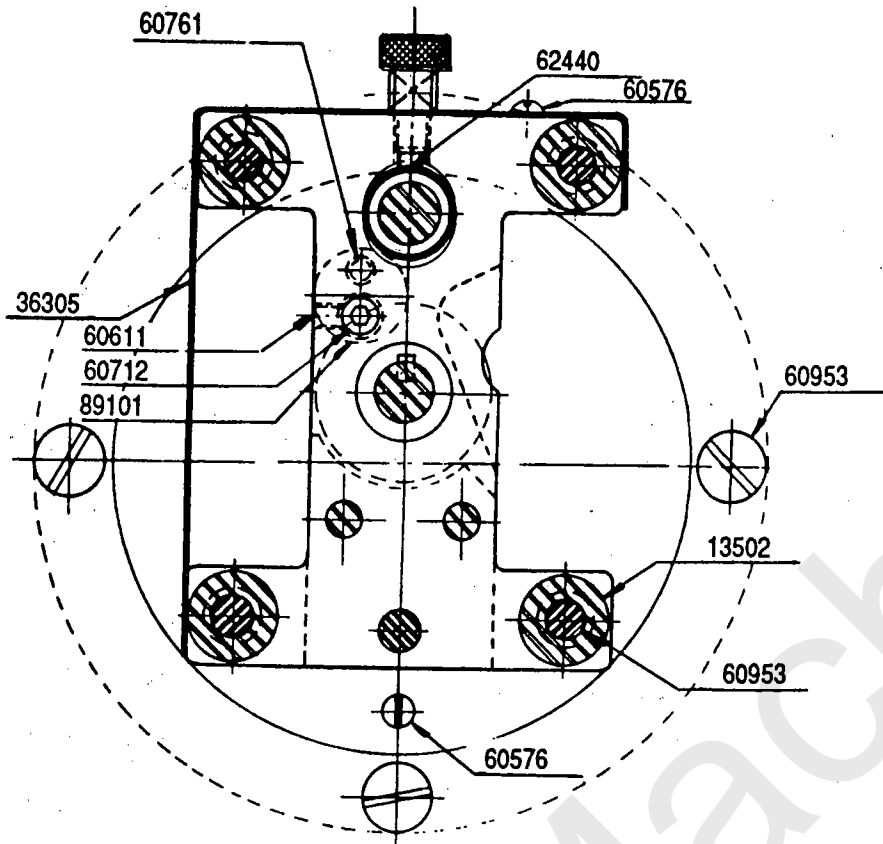

SECTION A-A

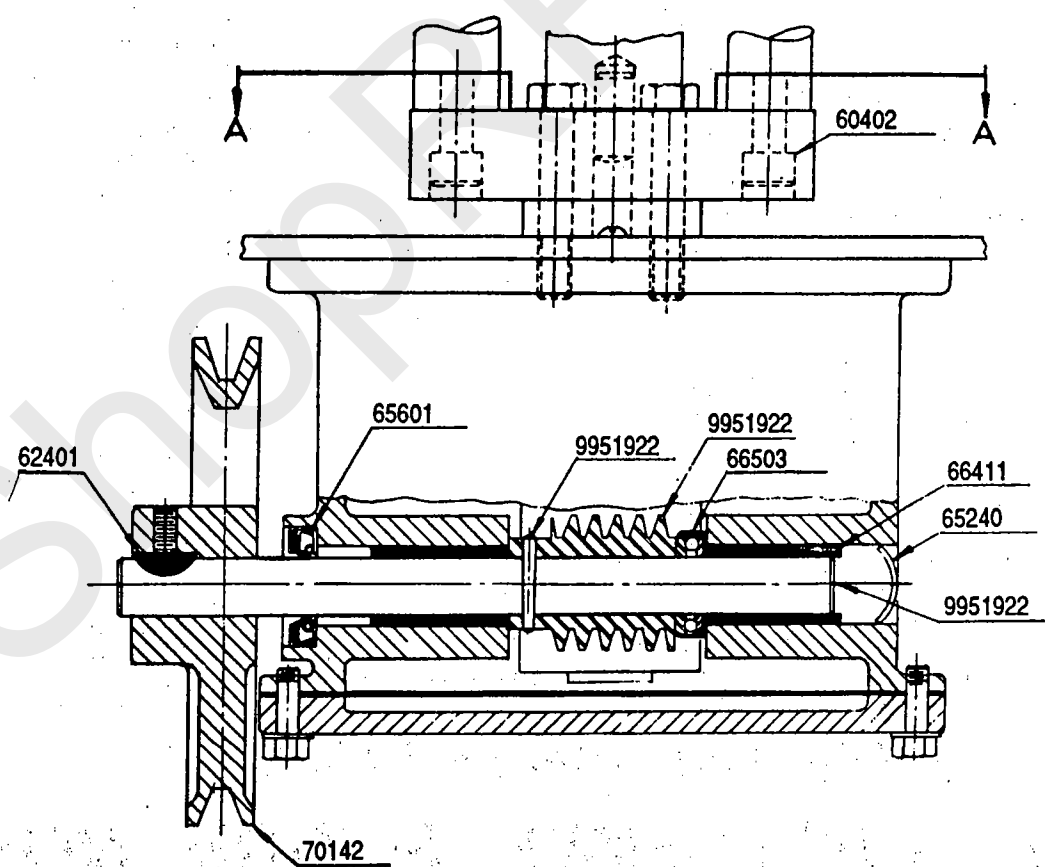

BUTTON PUNCH SNAP LOCK FLANGER

Parts List and Description

Part No.	Description	Pieces Per Unit	Part No.	Description	Pieces Per Unit
59022	Assembly Dwg.	1	89101	Lifter Button	1
40013	Gear Housing	1	11624	Plain Forming Roll	1
32037	Gear Housing Cover	1	11625	Knurled Forming Roll	1
65602	Gear Housing Gasket	1	62404	Woodruff Key #61	4
	Hor. Drive Shaft	1	66311	Thrust Race	4
9951922	Worm Gear	1	66310	Thrust Bearing	2
	Taper Pin	1	40071	Compensator Arm	1
66503	Thrust Bearing	1	14102	Gear	2
66411	Bronze Bushing	2	56562	Flange Plate Weldment	1
65240	Freeze Plug	1	13502	Vertical Spacer	4
65601	Oil Seal	1	9956563	Inner Race Assembly	2
13113	Vertical Drive Shaft	1	21881	Tension Screw Support	1
62103	Worm Wheel Washer	1	62640	Pivot Dowel	2
43111	Drive Gear	1	20951	Top Flanger Block	1
62401	Woodruff Key #9	2	40160	Bottom Flanger Block	1
66080	Housing Pin	2	71006	Spring	1
71151	Vertical Drive Shaft Collar	1	19004	Tension Spring Push Rod	1
22655	Lower Space Plate	1			
22651	Upper Space Plate	1			

Part No.	Description	Pieces Per Unit	Part No.	Description	Pieces Per Unit
62440	Race Support Key	2	58514	Stand	1
43412	Adjusting Handle	1	80030	Motor	1
11113	Button Punch-Male Roll	1	70140	Motor Sheave	1
11114	BUtoin Punch-Female Roll	1	70142	Machine Pulley	1
14104	Gear	2	70027	*V* Belt	1
11623	Adjusting Guide Roll	1	80481	BX Connectors	4
62631	Adjusting Guide Roll Shaft	1	80431	BX Cable	1
89105	Sensory	1	60875	Carriage Bolt - 3/8-16	4
60983	Head Screw	2	61120	Hex Nut - 3/8-16	4
71013	Spring	2	62029	Washer - 3/8	4
42411	Modified Woodruff Key #61	2	80204	Switch	1
14922	Tension Screw	1	80650	Handy Box	1
60576	Rd. Hd. Mach. Screw - #10-24	2	80675	Handy Box Cover	1
60611	Hol. Pt. Hol. Set Screw - 1/4-20	2	80525	Extension Cord	1
60680	Hol. Pt. Hol. Set Screw - 5/16-18	2	60048	5/16-18 x 1-1/4 H. H. Cap Screw	4
60761	Hol. Pt. Sq. Hd. Set Screw - 5/16-18	1	61101	5/16-18 HN. HVY. SF	4
61352	Hex Nut-Special - 1/2-20	1	62362	Washer - 5/16	8
60098	Hex Hd. Cap Screw - 3/8-16	4	60002	Hex Hd. Cap Screw - 1/4-20	1
60402	Soc. Hd. Cap Screw - 3/8-16	4	61061	Hex Jam Nut - 1/4-20	1
60953	Fl. Hd. Mach. Screw - 3/8-16	8	60712	Cup Pt. Hol. Set Screw - 7/16-20	1
60005	Hex Hd. Cap Screw - 1/4-20	4	62026	Washer - 3/8	2
62370	Lock Washer - 1/4	4	42201	Hex Nut - Special	1
39503	Cover	1			
36305	Side Cover	1			