

SUPER SPEED
CLEATFORMER®

MODEL No. 8900

OPERATING INSTRUCTIONS

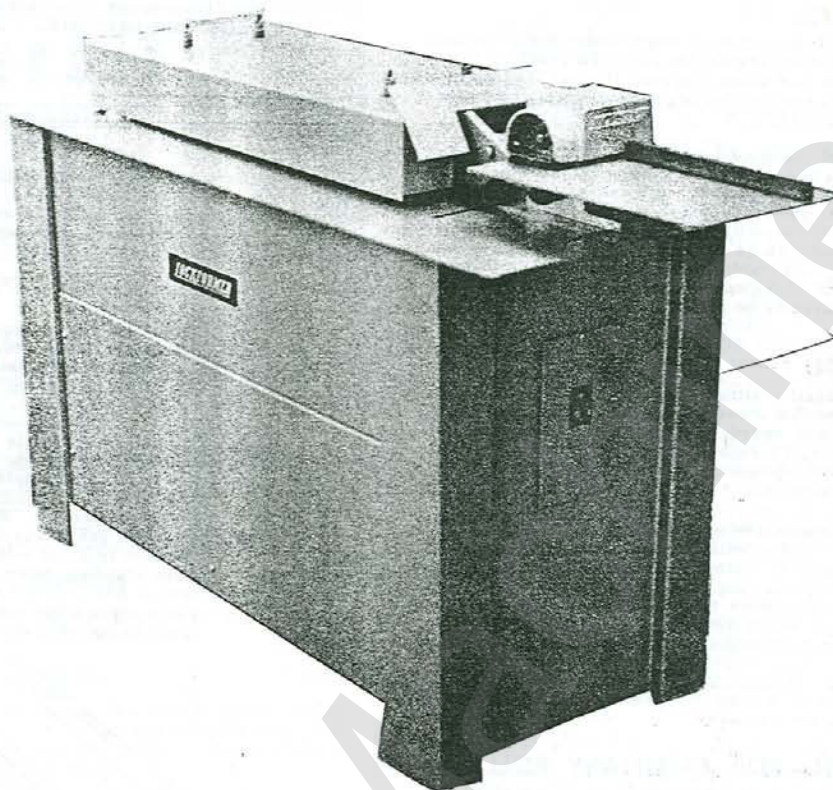

LOCKFORMER

Where the Machines of Tomorrow are Made TodaySM

711 OGDEN AVENUE
LISLE, ILLINOIS 60532

ELECTRICALS:

5 HP 220/440 volt three phase motor and controls, standard machine wired for 220 volt unless otherwise indicated.

MACHINE SPECIFICATIONS:

"S" CLEAT:

Capacity: 22 gauge galvanize or lighter
Stock Width: 3-5/8" + 000-1/32

OPERATION:

Start machine and place properly sheared material between gauge bars and feed material into the rolls.

Check end results and make changes accordingly.

ADJUSTMENTS:

Should the machine labor under load, the hold down studs are set too tight. To readjust, tighten the four studs that pass through the machine plates and then loosen approximately one quarter turn (90°).

Should machine continue to labor, loosen the two studs on the lead end of the machine to three-eighths (135°), or one-half turn (180°) loose. Upward bow can be adjusted by lowering the exit adjusting screw located on the exit adjustment gauge assembly. Downward bow can be compensated by adjusting the hold down studs located at the exit end of the machine. Side bow is caused by an unbalanced stud adjustment.

LUBRICATION:

Lubrication fittings for the high speed shafts are located under the stand auxiliary side panel. The high speed bearings should be lubricated after every eight hours of operation (recommended lubricant - Standard Oil Viscous #3, or equivalent.)

Roll stations #4 and #5 (part #G8904 and C-8905) are supplied with one polished angle surface to eliminate friction and allow the material to flow smoothly during the forming sequence. The rolls should be lubricated periodically with an application of #20 or #30 SAE lubricating oil to insure a smooth sliding surface.

NOTE: If machine is to be used or stored out-of-doors, an oil or grease film will prevent rusting of surfaces.

INSTRUCTIONS FOR AUXILIARY ROLLS:

Machine auxiliary shafts are designed to accommodate various auxiliary roll sets listed below. To install these rolls, proceed as follows:

1. Remove machine cover.
2. Remove rear section of table top side plate on side of machines rolls are to be mounted.
3. If auxiliary rolls are now on machine, remove retaining bolts and washers. Remove all parts not pertaining to the set to be used.
4. Place Woodruff keys on shafts.
5. Select the first pair of rolls which are marked "T-1" and "B-1" and place them on

the shafts at the entrance of the machine (Feed Side). Place the "T-1" roll on the upper shaft and "B-1" on the lower. Repeat procedure with roll stations #2, #3 and #4, etc. until all rolls have been mounted. All rolls marked "T" should be mounted on the top shafts and "B" rolls on the bottom shafts in numerical order. **NUMBER SIDE OF ROLLS MUST FACE OUTWARDS.**

6. After rolls are installed, fasten rolls with retaining cap screws and washers.

7. Mount entrance and exit gauge bars to stand, using slotted holes provided in stand table top and set entrance gauge by placing a straight edge along the outer edge of the auxiliary rolls; measure the required amounts in from this straight edge to the extreme ends of the entrance gauge bar. See Sketches #1, #6 & #6A using drive cleat rolls, mount second bar after gauge setting has been made. See schedule below for various auxiliary sets.

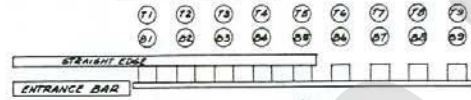

Auxiliary Roll Gauge Settings:

A. Type "S" double seam (22 gauge and lighter) uses approximately 1" material.

Gauge Setting 1-1/8"

B. Type "L" double seam (18 to 22 gauge galvanize) 7/16" pocket uses approximately 1-1/8" of material.

Gauge Setting 1-5/16"

C. Standing seam rolls (18-22 gauge galvanize) 3/4" height uses approximately 2-1/8" per completed seam. Forms both single and double edge by simple gauge attachment. NOTE: Two piece entrance gauge supplied. Drilled bar mounted to stand with clips attached to form standing seam gauge setting to drilled bar . . . 2" second gauge bar snaps under clips and is used for right angle flange. See Sketch #2 below:

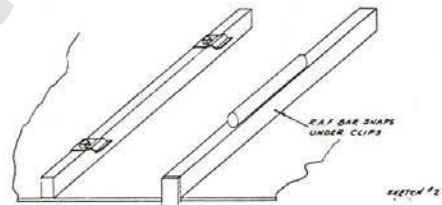

The top #8 and #9 rolls are not fastened by bolt and are allowed to float. The exit angle iron has an adjustable bar that can be lowered to exert pressure on the material, as it emerges from the rolls; thereby, straightening the finished section. See Sketch #3 below: Set exit gauge to the standing seam shape.

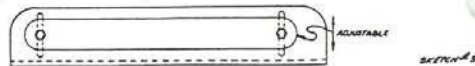

- D. Right angle flange rolls (16-24 gauge galvanized) on straight pieces only. Adjustable to 7/16" high.

Gauge Setting 1-5/16"

- E. 5/16" Auxiliary Pittsburgh (20 gauge and lighter) uses approximately 1" material.

Gauge Setting 1-11/16"/1-3/4"

A slight taper in gauge setting may be required.

NOTE: To install auxiliary opening roll holder, remove rolls from the #6 roll station and bolts that straddle the bottom 6 roll shaft (See Sketches #4 and #5). Place opening roll holder and slide on machine and fasten with the two 1/2-13 NC x 2" HHCS provided.

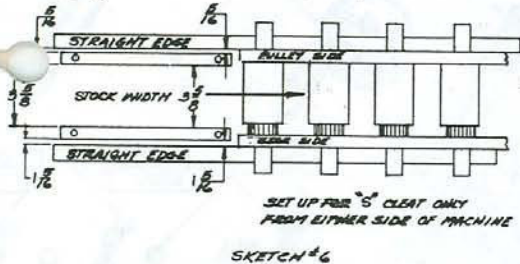
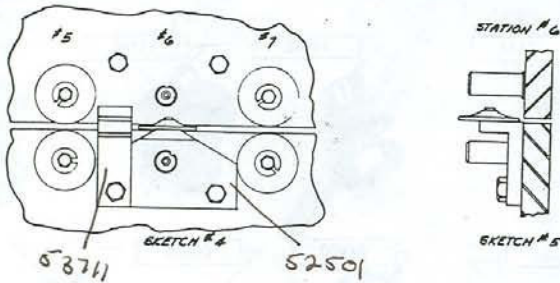

- F. Drive Cleat: (20 gauge and lighter) used 2-1/8" material.

Gauge Setting 2-1/8"

NOTE: Use gauge bar stamped DC (15/16" wide) as center bar for "S" cleat and drive cleat. Set outside gauge bar to width of material being used. (See Sketch #6).

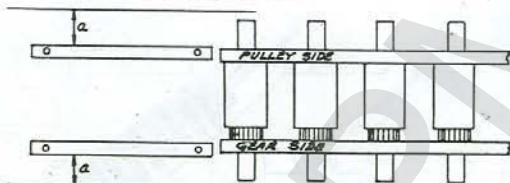

(a-a) SEE ROLL SET TO BE USED

SKETCH #6A

- G. Combination 3-in-1 rolls (capacity 22 gauge and lighter), also 2-in-1, uses approximately 1-3/4" on "T" section, 1-1/8" on standing seam and 1/2" on right angle flange. Standard installation places rolls on pulley side of machine. Gear side mounting may be available on request.

Gauge Settings - 3-in-1 Gauge Bar:

Top Step "T" section 2-1/16"
Middle Step standing seam . . . 1-1/2"
Bottom Step right angle flange 15/16"

Gauge Settings - Combination 2-in-1"

Top Step "T" section 2-1/16"
Bottom Step standing seam . . . 1-1/2"

NOTE: The combination gauge acts as a center guide for the "S" cleat and combination 3-in-1 rolls.

When the first setting is made, the other two will automatically be correct. The other two shapes can be made by placing material to the proper gauge step. The exit angle iron gauge has an adjustable bar that can be lowered to exert pressure on the material as it emerges from the rolls - thereby, straightening the finished section. See Sketch #3.

NOTE: WHEN ADJUSTING THE EXIT GAUGE FOR THE 3-in-1 COMBINATION, BE SURE TO SET IT TO THE "T" SECTION OR DAMAGE WILL RESULT BY MATERIAL INTERFERENCE WITH THE GAUGE BAR.

9. When changing rolls, loosen the exit gauge and move it to the extreme ends of the table slots away from where the material will pass. Run a test piece of material through the rolls and stop the machine as the lead edge of the formed material reaches the end of the exit table. Set the exit gauge to the formed material -- the gauge should be flush with, but not bearing against, the material unless side pressure is required for straightening. Adjustment of the pressure on the 3/8" studs that pass through the plates will effect the shape and the tendency of the material to hold to the entrance gauge. It is important that, when changing rolls, all parts pertaining to each set be removed from the machine and all parts for the set to be mounted be included on assembly.

10. Replace top cover and stand back plate.
11. Place material against gauge bar and feed into machine.

NOTE: Roll coding is such that on similar rolls, the numbers will designate more than one station. EXAMPLE: Combination 3-in-1 rolls have three rolls stamped LTC-2-3-B-7-8-9. These rolls are to be placed one on the bottom 7 shaft and the other two on B-8 and 9.

www.com

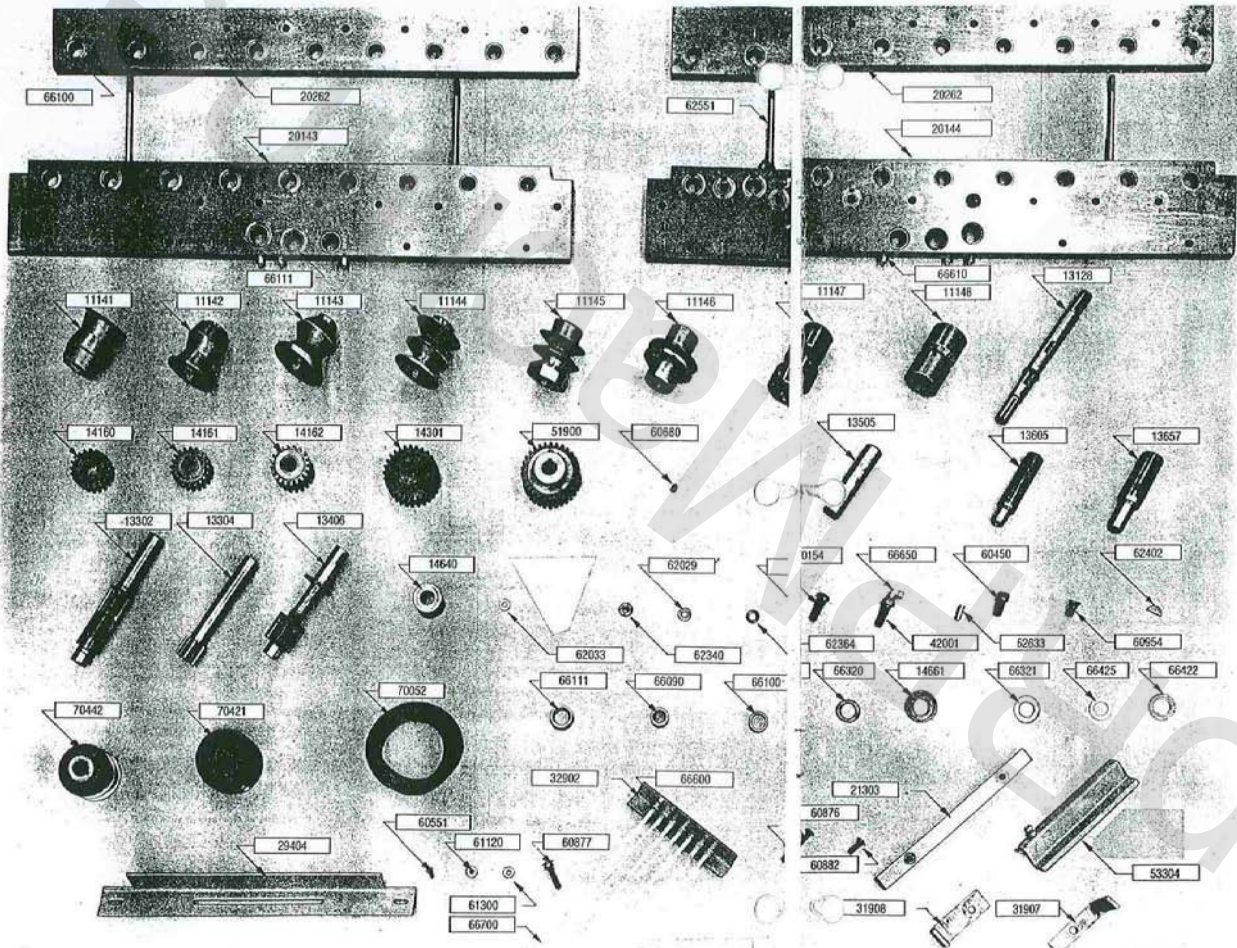

PART NO.	DESCRIPTION	PCS. PER UNIT
11141	89 T-B1	2
11142	89 T-B2	2
11143	89 T-B3	2
11144	89 T-B4	2
11145	89 T-B5	2
11146	89 T-B6	2
11147	89 T-B8	2
11148	89T-B9	2
11257	89 T-B7	2
13128	Roll Shaft	18
- 13302	1st Drive Shaft	1
- 13304	2nd Drive Shaft	1
- 13406	3rd Drive Shaft	1
13505	Plain Spacer	13
13605	Idler Spacer	7
13657	Main Idler Spacer	1
14160	Drive Gear	16
14161	Idler Gear (takes 1-66090)	7
14162	Main Idler Gear (takes 2-66100)	1
14301	Drive Gear	1
14640	Collar	1
14661	Thrust Collar	2
20143	Btm. Ft. Ptl.	1
20144	Btm. Ptl.	1
20202	Upr. Bk. Ptl.	2
21303	Est. Ga. Bar	2
25676	Jack Base	2
29469	Motor Base	2
31907	Sheet Side Gear	1
31908	Sheet Side Roll	1
32902	Lube Conn Holder	1
37000	Grease Fitting Shim	2
42001	Lube Bol	1
51684	Cover	1
51900	Fibr Gear Assy	1
53304	Exit Ga. Assy.	1
58509	Stand Complete	1
60052	5/16-18 x 1 Hex C.S.	1
60997	3/8-16 x 1-3/4 Hex C.S.	1
60166	1/2-13 x 3-1/2 Hex C.S.	2
60228	1/2-13 x 1-3/4 Hex C.S.	42
60402	3/8-16 1 SHCS	2
60450	1/2-13 1 SHCS	1
60575	10-24-3/8 RHMS	4
60593	10-32 x 7/16 F.H. Screw	2
60680	3/8-16 3/8 SSS	2
60875	3/8-16 x 1 CB	6
60877	3/8-16 1-3/4 CB	4
60954	1/2-13 1 FHSCS	4
61040	10 24 HN	4
61101	5/16-18 HN Hvy. SF	1
61120	3/8-16 HN Hvy. SF	6
61122	3/8-16 HN Fin.	4
61160	1/2-13 HN Hvy. SF	6
61300	3/8-16 Jam Nut SF	4
62026	3/8 x .052 Washers	4
62340	3/8 EIW Washer	48
62029	3/8-1/16 Washer	18
62360	3/16 Lockwashers	3
62363	3/8 Lockwashers	12
62364	1/2 Lockwasher	43

62631
 53711 - ENT. GUIDE ASSY. 52501
 - PEN FOR OPENING ROLL HOLDER
 - OPENING ROLL HOLDER AUX SIDE.

Continued on page 6

8900 CLEATFORMER PARTS LIST
Continued from page 5

PART NO.	DESCRIPTION	PCS. PER UNIT
62402	15 wrdr Key	39
62551	3/8-16 6-1/2 Stud	4
62633	3/8-1 Dwl	4
66090	B1416 Torr Brg.	7
66100	B1612 Torr Brg.	38
66111	HJ 162412 Torr Brg.	6
66320	NTA 1625 Torr Brg.	2
66321	1-3/32 washer HT	2
66422	TT1503 2 Thrust Brg.	7
66425	TT1709 1 Thrust Brg.	42
66600	886L Fern Couplg.	7
66610	888L Half Union	7
66640	1610 Grs. Fitting	7
66650	Angle Body	1
66700	Tubing	121
70052	5L 480 Belt	2
70421	2 BK 32 1 Shv.	1
70442	2 BK 45 1-1/8 Shv.	1
80080	5 HP 3 60 1800 184	1
80103	Mtr. Control	1
80423	BX Cable 12 3 58	1
80483	BX Conn. 3/8	1
80601	Rg. Fng. Terminal	3
80928	Back Enclosure	1
82254	Heater Element	2
85178	Lockformer Logo	1
85339	Cleatformer Name Plate	1

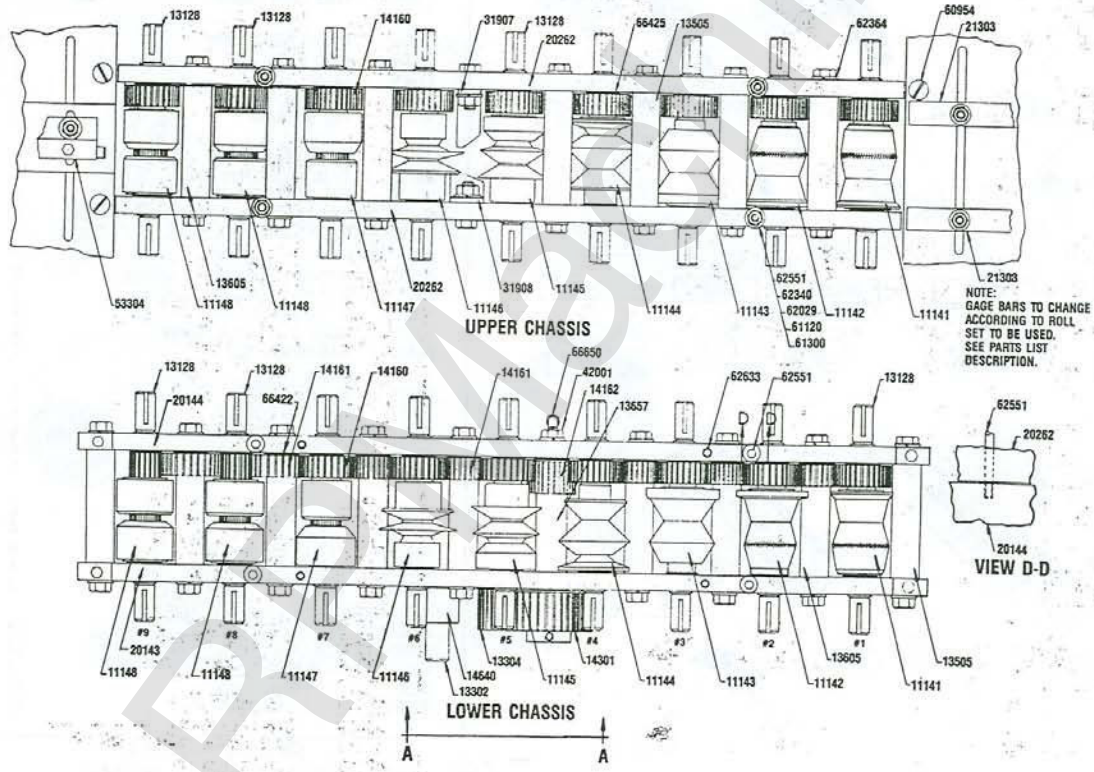
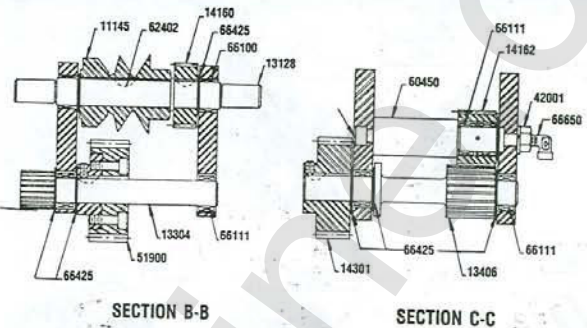
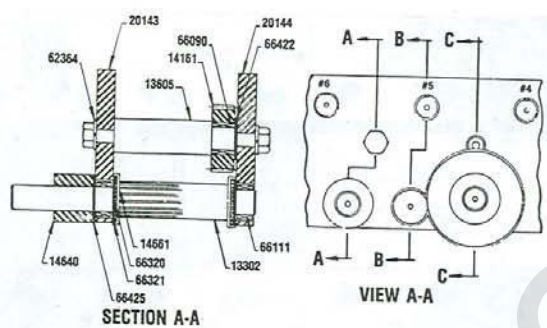

Maximum Capacity of Unit: 22 Ga. Galv. (.0350" Material)
 Minimum Length of Cleat to be cut: 9" minimum

Note: "S" Cleat Slitting attachments supplied with Super Speed Cleatformer (Model 8900) can be mounted by starting with Step No. 4. All Auxiliary gauges are factory set and should not require any further adjustments.

TO INSTALL ON SERIES 8900 SUPER SPEED CLEATFORMER

1. Remove present cover and notch entrance end per sketch as required.

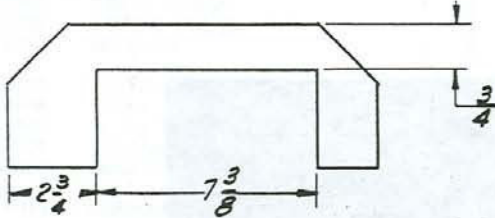

Figure 1 - Feed-End View of Cover of Super Speed Cleatformer Model 8900

2. Remove entrance gauge bars of present "S" Cleat and elongate table lots per sketch, as required. Suggestion: Drill 3/8 hole then cut out slot. Note: On machine tables with continuous slot the above elongation is not required.

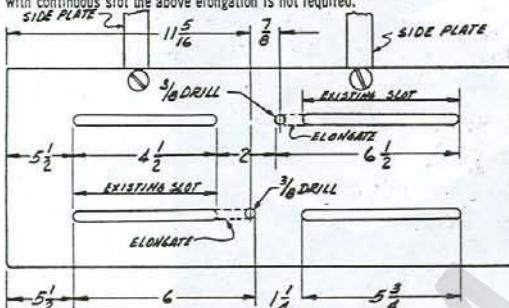

Figure 2 - Entrance Table Detail Model 8900

3. Replace Auxiliary entrance Gauges using special gauge bars and bolts provided in carton. Reset gauges as outlined in Chart I and in Super Speed Machine operating instructions.

TO OPERATE "S" CLEAT CUTTER ATTACHMENT

1. Check settings and make sure all mounting bolts are tight.
2. Start machine and place the material against the entrance gauge bar of the slitting attachment and feed the stock into the slitting rolls. The slit material will automatically deflect downward to the forming roll while the piece in the operator's hand will deflect upward to clear the machine. The slitter will cut straight as long as the material which has not gone thru the slitting rolls is held against the entrance gauge bar.

Note: When running long sheets it is advisable that the sheet be supported at approximately the same height as the slitting attachment entrance table.

ADJUSTMENT

The slitter is properly adjusted and tested before shipment. Should the gauge accidentally become misaligned, refer to installation instructions paragraph 5 on 8900. If the cleat runs out or if material distribution is not correct, check the mounting of the attachment making sure the unit is mounted parallel to the machine side plates and settings are correct.

When the slitting rolls need sharpening remove the bottom roll and grind it on the O.D. to remove any nicks and present a clear sharp edge. The top roll has two cutting edges, when the resharpened lower roll is reinstalled merely reverse the side of the roll presenting a new cutting edge. Note: When ordering parts for this unit, please SPECIFY the SERIAL NUMBER stamped on the name Plate.

CAUTION: Machine will jam if pieces less than 9" are used.

In case of jam-up, remove sheet deflector casting 56574 and remove material from unit.

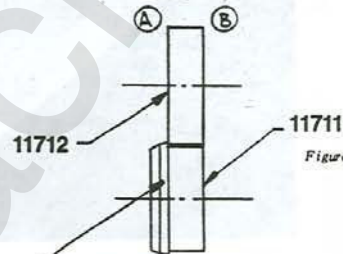

Figure 7 - Diagram of Rolls

Maximum Capacity of Unit: 22 Ga. Galv. (.0350" Material)
 Minimum Length of Cleat to be cut: 9" minimum

Note: "S" Cleat Slitting attachments supplied with Super Speed Cleatformer (Model 8900) can be mounted by starting with Step No. 4. All Auxiliary gauges are factory set and should not require any further adjustments.

TO INSTALL ON SERIES 8900 SUPER SPEED CLEATFORMER

1. Remove present cover and notch entrance end per sketch as required.

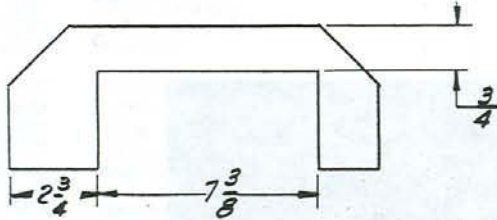

Figure 1 - Feed-End View of Cover of Super Speed Cleatformer Model 8900

2. Remove entrance gauge bars of present "S" Cleat and elongate table lots per sketch, as required. Suggestion: Drill 3/8 hole then cut out slot. Note: On machine tables with continuous slot the above elongation is not required.

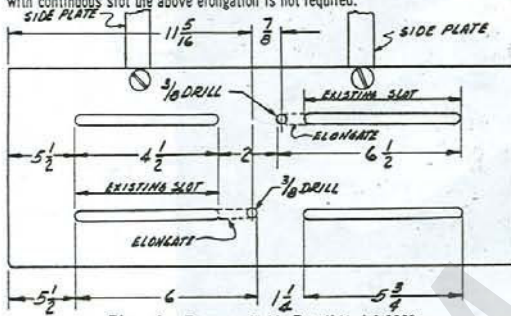

Figure 2 - Entrance Table Detail Model 8900

3. Replace Auxiliary entrance Gauges using special gauge bars and bolts provided in carton. Reset gauges as outlined in Chart I and in Super Speed Machine operating instructions.

TO OPERATE "S" CLEAT CUTTER ATTACHMENT

1. Check settings and make sure all mounting bolts are tight.
2. Start machine and place the material against the entrance gauge bar of the slitting attachment and feed the stock into the slitting rolls. The slit material will automatically deflect downward to the forming roll while the piece in the operator's hand will deflect upward to clear the machine. The slitter will cut straight as long as the material which has not gone thru the slitting rolls is held against the entrance gauge bar.

Note: When running long sheets it is advisable that the sheet be supported at approximately the same height as the slitting attachment entrance table.

ADJUSTMENT

The slitter is properly adjusted and tested before shipment. Should the gauge accidentally become misaligned, refer to installation instructions paragraph 5 on 8900. If the cleat runs out or if material distribution is not correct, check the mounting of the attachment making sure the unit is mounted parallel to the machine side plates and settings are correct.

When the slitting rolls need resharpening remove the bottom roll and grind it on the O.D. to remove any nicks and present a clear sharp edge. The top roll has two cutting edges, when the resharpened lower roll is reinstalled merely reverse the side of the roll presenting a new cutting edge. Note: When ordering parts for this unit, please SPECIFY the SERIAL NUMBER stamped on the name Plate.

CAUTION: Machine will jam if pieces less than 9" are used.

In case of jam-up, remove sheet deflector casting 56574 and remove material from unit.

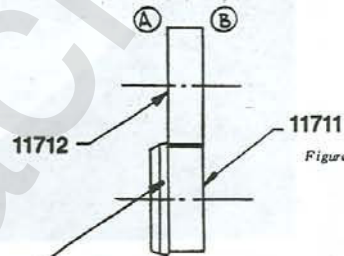













Figure 7 - Diagram of Rolls

**ENTRANCE GAUGE TABLE SETTINGS
SUPER SPEED CLEATFORMER MODEL 8900**

For aligning entrance Gauge Bars refer to Drawing No. 3 for Dimensions and Settings.

CHART 1

AUX. ROLL SETS	LOCATION	MACHINE	ENTRANCE GAUGE TO BE USED	ENTRANCE GAUGE SETTING FROM EDGE OF ROLL
5/16 Pittsburgh	Gear Side	Super Speed Cleatformer	 PT. NO. 52907	1-11/16" / 1-3/4"
Type L & S Double Seam	Gear Side	Super Speed Cleatformer	 PT. NO. 52907	Type S 1-1/8" Type L 1-5/16"
Standing Seam	Gear Side	Super Speed Cleatformer	 PT. NO. 52907	2"
24 Female Button Lock	Gear Side	Super Speed Cleatformer	 PT. NO. 52907	2-3/32" / 2-5/32"
Drive Cleat	Gear Side	Super Speed Cleatformer	 PT. NO. 52907	2-1/8"
3 in 1	Gear Side	Super Speed Cleatformer	 PT. NO. 52908	Top Step 2-1/16" Middle Step 1-1/2" Bottom Step 15/16"
2 in 1	Gear Side	Super Speed Cleatformer	 PT. NO. 52909	Top Step 2-1/16" Bottom Step 1-1/2"
24 Female Button Lock	Plate Side	Super Speed Cleatformer	 PT. NO. 52907	2-3/32" / 2-5/32"
Drive Cleat	Plate Side	Super Speed Cleatformer	 PT. NO. 52907	2-1/8"
3 in 1	Plate Side	Super Speed Cleatformer	 PT. NO. 52908	Top Step 2-1/16" Middle Step 1-1/2" Bottom Step 15/16"
2 in 1	Plate Side	Super Speed Cleatformer	 PT. NO. 52909	Top Step 2-1/16" Bottom Step 1-1/2"

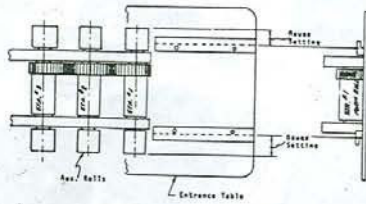

Figure 3 - Model 8900-Refer to Chart 1, Entrance Gauge Table Settings.

Note: There is an interference when using standard 2 in 1 and 3 in 1 Entrance Gauge Bars when the slitter is attached to the machine. It will, therefore, be necessary to furnish a special Entrance Gauge Bar for this operation. We will need the Serial No. of the machine and the type of rolls (2 in 1 or 3 in 1) for which the gauge bar is required. Please return the existing Gauge Bar for credit. New entrance gauge bar will be furnished from Lockformer, Chicago Factory.

slitting attachment on entrance table so that the spur gear of the attachment meshes with the gear of the No. 1 forming roll. Refer to Drawing No. 4 for set-up.

5. By placing the template furnished across the back of the slitting attachment, casting and the machine plate, bolt in place per sketch: Note: 7/32" Dimension is fabricated into the template. Template edges must be parallel to Machine plate and slitter attachment casting.

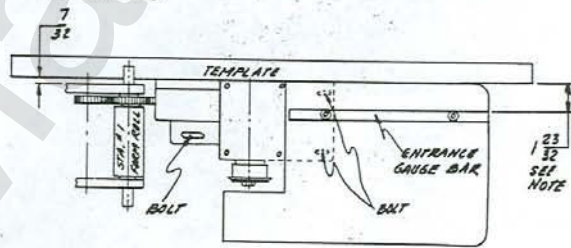
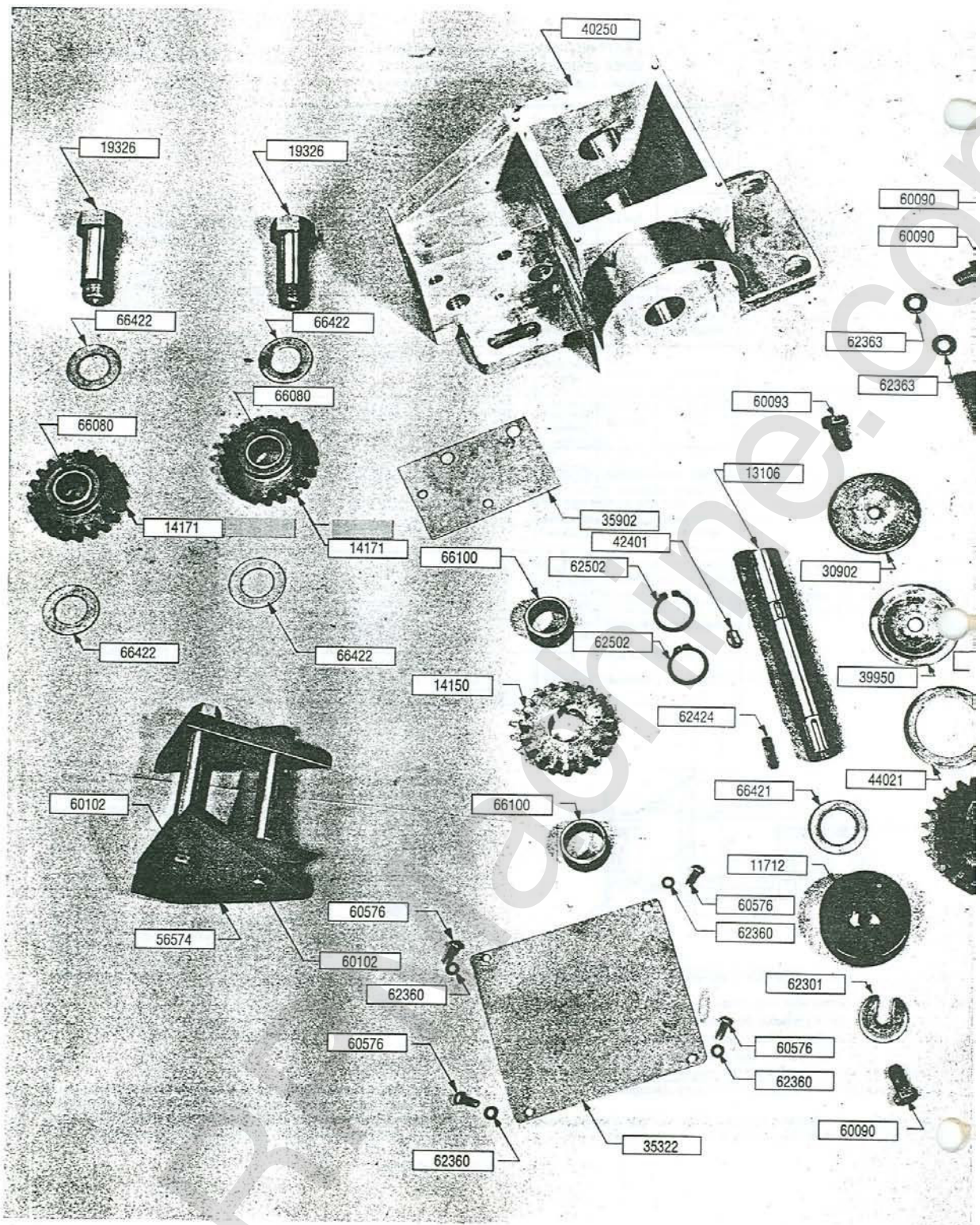

Figure 4 - Model 8900

Alternate Set-Up Procedure:

Place straight edge across the back of the slitter attachment casting and measure 7/32" from straight edge to machine plate. Take measurements at least 12" apart to insure slitter attachment is parallel to machine plate: Note: Entrance gauge bar is factory set and should not need adjustment. Setting is given for reference only.

6. Replace machine cover.



shop

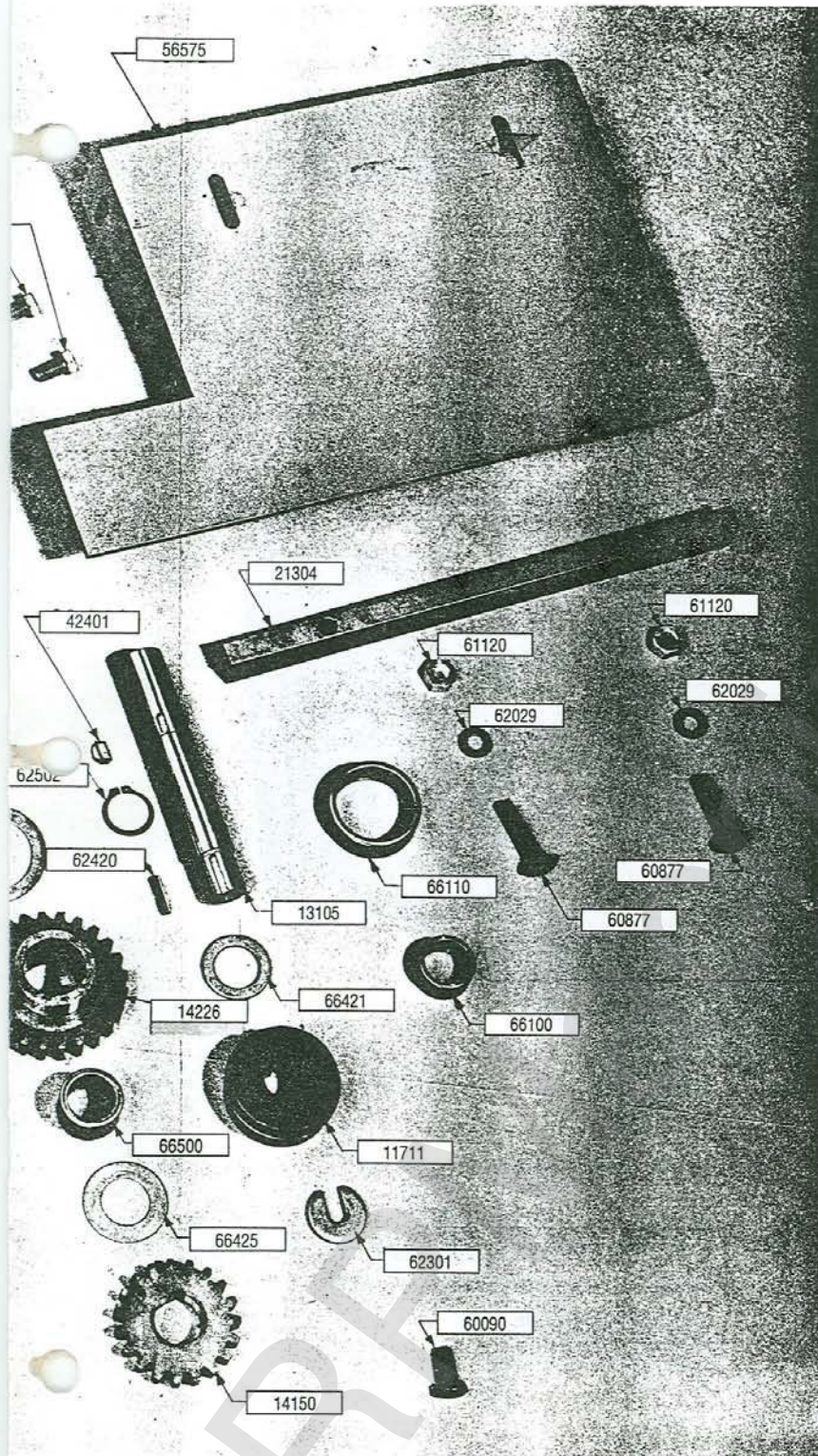

PART NO.	DESCRIPTION	REQ. PER UNIT
11711	Bottom Slitting Roll	1
11712	Top Slitting Roll	1
13105	Bottom Roll Shaft	1
13106	Top Roll Shaft	1
14150	Drive Gear	2
14171	Idler Gear	2
14226	Clutch, Gear	1
19326	Idler Stud	2
21304	Entrance Gauge	1
30902	Washer	1
*34700	Defl. Guard	1
35322	Cover Plate	1
35902	Wear Plate	1
*35979	Template	1
39950	Thrust Washer	1
40250	Main Housing	1
44021	Thrust Washer	1
56574	Deflector	1
56575	Entrance Table	1
*60045	5/16-18 x 1/2 HHCS	2
60090	3/8-16 x 3/4 Hex Cap Screw	4
60093	3/8-16 x 1 Hex HD Cap Screw	1
60102	3/8-16 x 5" Lg. Hex. Capscrew	2
*60498	5/16-18 x 3/8 SHCS	1
*60571	8-32 x 3/4" RHMS	2
60576	10-24 x 1/2" Lg. Rd. Hd. Mach. Screw	4
*60795	4 x 3/16 Drive Scr.	2
*60876	3/8-16 x 1-1/4 CB	3
60877	3/8-16 x 1-3/4" Lg. Carriage Bolt	2
*61020	8-32 Hex Nut	2
61120	3/8-16 Hex. Nut	2
*62002	3/16 x .049 Wsr.	2
62029	3/8 ID Plain Washer	2
62301	"C" Washer	2
62360	3/16 Lockwasher	4
62363	3/8 Lockwasher	5
62420	3/16 Sq. Key	1
*62424	3/16 Sq. Key 1/2	1
62502	Retaining Ring	3
66080	Bearing	2
66100	Bearing	3
66100	Bearing	1
66421	Thrust Washer	2
66422	Thrust Washer	4
66425	Thrust Washer	1
*66430	TT150-2 Brg.	1
66500	Clutch	1
*71154	1" Collar	1

*Not Shown

NUMBER
WHEN ORDERING
PARTS

PARTS LIST

OLD NUMBER CONVERSION

New Part No.	Old Part No.	Description	Pcs. Per Unit	New Part No.	Old Part No.	Description	Pcs. Per Unit
20144	C8900AB	Btm. Pit.	1	66090	C8945	B1416 Torr Brg.	7
20262	C8900AT	Upr. Bk. Pit.	2	66100	C8946	B1612 Torr Brg.	33
20143	C8900GB	Btm. Frt. Pit.	1	66320	C8947	NTA 1625 Torr Brg.	2
11141	C8901	89 T B1	2	14661	C8948	Thrust Collar	2
11142	C8902	89 T B2	2	66321	C8949	1 3/32 washer HT	2
11143	C8903	89 T B3	2	66425	C8950	TT1709 1 Thrust Brg.	42
11144	C8904	89 T B4	2	66422	C8951	TT1503 2 Thrust Brg.	7
11145	C8905	89 T B5	2	31907	C8952-1	Sheet Slide Gear	1
11146	C8906	89 T B6	2	31908	C8952	Sheet Slide Roll	1
11147	C8907	89 T B7	2	50008	C8953	Stand Complete	1
11148	C8908	89 T B8	2	29404	C8953-9	Motor Base	2
13128	C8910	Roll Shaft	18	60501	C8953-12	1/4 20 1/2 FHmS	8
14160	C8911	Drive Gear	18	60551	C8953-13	1/4 20 1/2 RHMS	9
14161	C8912	Idler Gear (takes 66090)	7	50921	C8954	Cover	1
14162	C8913	Main Idler Gear (takes 2-66100)	1	61120	C8955	3/8 16 HN Hvy. Sf.	10
14301	C8914	Drive Gear	1	61300	C8956	3/8 16 Jam Nut SF	4
51900	C8915	Fibr Gear Assy	1	60877	C8957	3/8 16 1 3/4 CB	4
60402	C8915C	3/8 16 1 SHCS	2	60876	C8958	3/8 16 1 1/4 C3	4
60580	C8916	3/8 16 3/8 SSS	2	60882	C8959	3/8 16 3/4 C3	2
13505	C8917	Main Spacer	13	21303	C8960	Ent. Ga. Bar	2
13605	C8918	Idler Spacer	7	53304	C8961	Exit Ga. Assy.	1
13657	C8919	Main Idler Spacer	1	33904	C8962	Zee Bar	1
13302	C8920	1st Drive Shaft	1	60052	C8964	5/16 18 1 HHcs	1
13304	C8921	2nd Drive Shaft	1	61101	C8965	5/16 18 HN Hvy. SF	1
13406	C8922	3rd Drive Shaft	1	32902	C8967	Lube Conn Holder	1
14640	C8923	Collar	1	66640	C8967A	1610 Grs. Fitting	7
62033	C8924	3/8 040 washer	4	66610	C8967B	888L Half Union	7
62551	C8926	3/8 16 6 1/2 Stud	4	66650	C8967C	Angle Body	1
62340	C8927A	3/8 Blvl Washer	48	66600	C8967D	886L Fem Couplg.	7
62029	C8928	3/8 1/16 W	18	66700	C8967E	15 Nyla Tubing	45
62364	C8929	1/2 Lck washer	43	66700	C8967F	19 Nyla Tubing	76
60154	C8930	1/2 13 1-1/2 HHCS HT	42	60575		10 24 3/8 RHMS	4
42001	C8931	Lube Bolt	1	60795		4 3/16 Dr. Scr. U Cad	4
62633	C8932	3/8 1 Dwl	4	60797		4 1/4 Dr. Scr.	4
60450	C8933	1/2 13 1 SHCS	1	60875		3/8 16 x 1 CB	4
60954	C8934	1/2 13 1 FHSCS	4	61040		10 24 HN	4
62402	C8935	15 wdrd Key	39	61122		3/8 16 HN Fin.	4
80080	C8936	5 HP 3 60 1800 184	1	61160		1/2 13 HN Hvy. Sf.	2
80102	C8937	Mtr. Control	1	66321		TRC 1625 Torr Race	2
80333	C8938	N33 Heater Element	2	80601		Rg. Fng. Terminal	3
80483	C8939	BX Conn. 3/P	1	85153		Cleatformer Nam. Plt.	1
80423	C8940	BX Cable 12	1	85164		Lockformer Logo	1
70421	C8941	2 BK 32 1 Shv.	1				
70442	C8942	2 BK 45 1 1/8 Shv.	1				
70052	C8943	5L 480 Belt	2				
66111	C8944	HJ 162412 Torr. Brg.	6				

AUXILIARY ROLL SETS

9999204Male

Button Punch Snap Lock

24 to 30 ga. set

shop