

Operating Instructions

LOCKFORMER

Where the Machines of Tomorrow are Made TodaySM

TRIPLEX CLEATFORMER AND "S" AND DRIVE CLEAT CUTTER ATTACHMENT

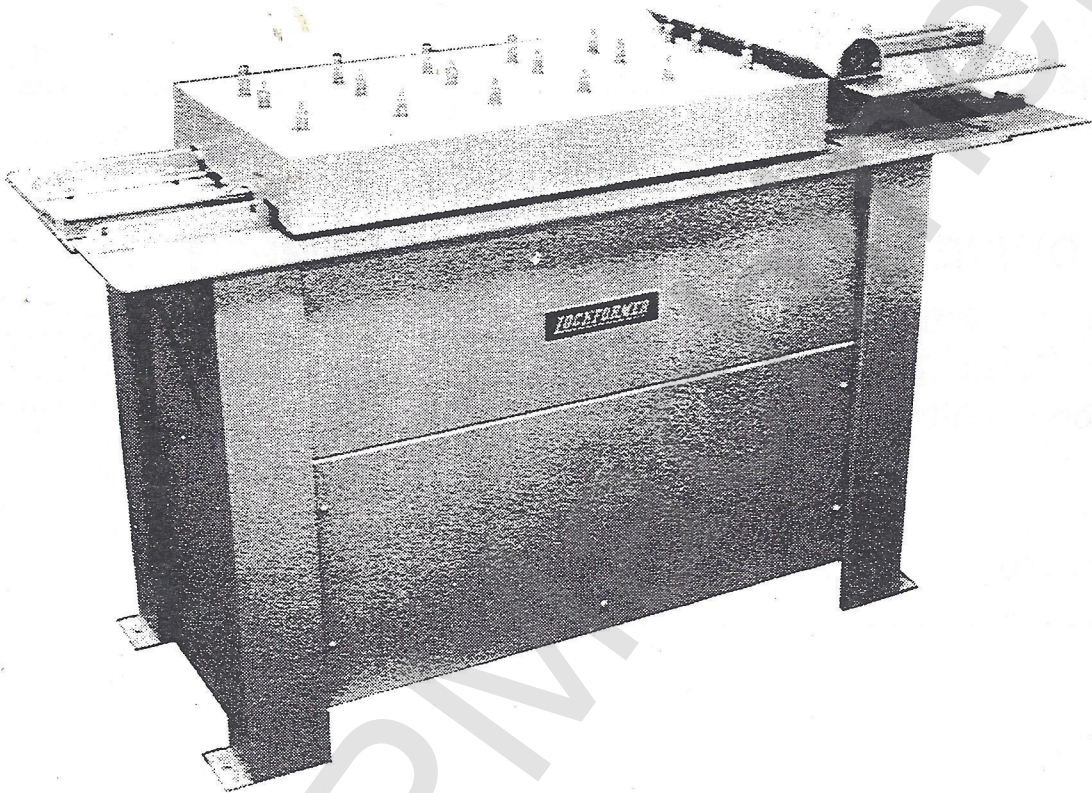

THE LOCKFORMER COMPANY
711 W. OGDEN AVENUE • LISLE, IL 60532

TRIPLEX CLEATFORMER

Instructions

ELECTRICALS:

5 HP 230/460 volt three phase motor and controls, standard machine wired for 230 volt unless otherwise indicated.

MACHINE SPECIFICATIONS:

"S" CLEAT

Capacity: 22 gauge galvanize or lighter
Stock Width: 3-5/8" + 000-1/32

DRIVE CLEAT

Capacity: 20 gauge galvanize or lighter
Stock width: 2-1/8" + 000-1/32

OPERATION:

A. Strip Stock

Start machine and place properly sheared material between gauge bars and feed material into the rolls.

Check end results and make changes accordingly.

B. Sheet Feed with Slitter (Optional)

Start machine and place sheet against proper gauge bar and feed material into the slitting rolls being sure to keep sheet against gauge bar. Do not force or try to influence the sheet in any way. Machine will automatically feed cut sheet into the forming rolls and deflect balance of sheet over machine cover. On long sheets, best results will be had by turning sheet so that the trail end on the first cut becomes the lead end on the second cut, etc. This procedure will eliminate any tendency for "Trailing-Off" on the slit part.

TRIPLEX CLEATFORMER

Instructions

ADJUSTMENTS:

The top plate and roll assembly is split into 3 zones of 3 rolls each with simple six point adjustment for each zone. Begin adjustment by tightening all hold down nuts to their solid position then loosen as follows:

- A. Zone 1 all studs 1/2 turn loose
- B. Zone 2 all studs 3/4 turn loose
- C. Zone 3 all studs 1 turn loose

Should machine labor under load stud settings should be loosened 1/8 to 1/4 turn.

Upward bow can be adjusted by lowering the exit adjusting screw located on the exit adjustment gauge assembly. Downward bow can be compensated by adjusting the hold down studs located at the exit end of the machine. Side bow is caused by an unbalanced stud adjustment.

LUBRICATION:

Lubrication fittings for the high speed shafts are located under the stand auxiliary side panel. The high speed bearings should be lubricated after every eight hours of operation (recommended lubricant-Standard Oil Viscous #3, or equivalent.)

Roll stations #4 and #5 (part 11144 and 11145) on "S" Cleat are supplied with three polished angle surfaces to eliminate friction and allow the material to flow smoothly during the forming sequence. The rolls should be lubricated periodically with an application of #20 or #30 SAE lubricating oil to insure a smooth sliding surface.

NOTE: If machine is to be used or stored out-of-doors, an oil or grease film will prevent rusting of surfaces.

INSTRUCTIONS FOR AUXILIARY ROLLS:

Machine auxiliary shafts are designed to accommodate various auxiliary roll sets listed below. To install these rolls, proceed as follows:

1. Remove machine cover.
2. Remove table top side plate on side of machine rolls are to be mounted.
3. If auxiliary rolls are now on machine, remove retaining bolts and washers. Remove all parts not pertaining to the set to be used.
4. Place keys on shafts.
5. Select the first pair of rolls which are marked "T-1" and "B-1" and place them on the shafts at the entrance of the machine (Feed Side). Place the "T-1" roll on the upper shaft and "B-1" on the lower. Repeat procedure with roll stations #2, #3, and #4, etc. until all rolls have been mounted. All rolls marked "T" should be mounted on the top shafts and "B" rolls on the bottom shafts in numerical order. **NUMBER SIDE OF ROLLS MUST FACE OUTWARD.**
6. After rolls are installed, fasten rolls with retaining cap screws and washers.

TRIPLEX CLEATFORMER

Instructions

7. Mount entrance and exit gauge bars to stand, using slotted holes provided in stand table top and set entrance gauge by placing a straight edge along the outer edge of the auxiliary rolls; measure the required amounts in from this straight edge to the extreme ends of the entrance gauge bar. See schedule below for various auxiliary sets.

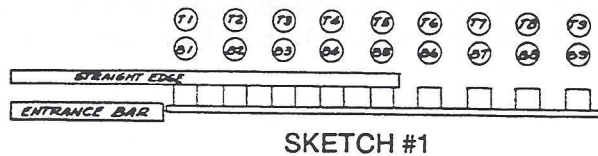

Auxiliary Roll Gauge Settings:

- A. Type "S" double seam (22 gauge and lighter) uses approximately 1" material.
Gauge Setting (Front) 1-1/8" (Back) 1-3/16"
- B. Type "L" double seam (18 to 20 gauge galvanize) 7/16" pocket uses approximately 1-1/8" material.
Gauge Setting (Front) 1-5/16" (Back) 1-3/8"
- C. Standing seam rolls (18-22 gauge galvanize) 3/4" height uses approximately 2-1/8" per completed seam. Forms both single and double edge by simple gauge attachment.

NOTE: Two piece entrance gauge supplied. Drilled bar should be mounted to stand with clips in order to form standing seam. Gauge setting to drilled bar . . . 2". Second gauge bar snaps under clips and is used for right angle flange. See Sketch #2:)

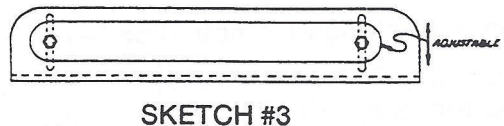
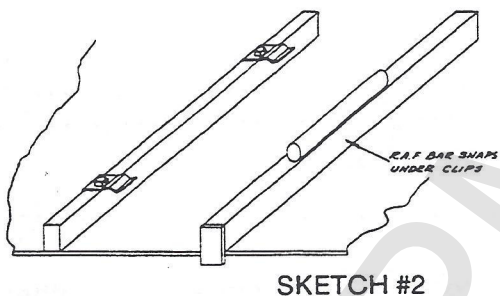

The top #8 and #9 rolls are fastened by bolts and are allowed to float. The exit angle iron has an adjustable bar that can be lowered to exert pressure on the material, as it emerges from the rolls; thereby, straightening the finished section. See Sketch #3: Set exit gauge to the standing seam shape.

TRIPLEX CLEATFORMER

Instructions

- D. Right angle flange rolls (16-24 gauge galvanize) on straight pieces only. Adjustable to 7/16" high.
 Gauge Setting1-5/16"
- E. 5/16" Auxiliary Pittsburgh (20 gauge and lighter) uses approximately 1" material.
 Gauge Setting1-11/16" to 1-3/4"
- A slight taper in gauge setting may be required.

NOTE: To install auxiliary opening roll holder, remove rolls from the #6 roll station and bolts that straddle the bottom 6 roll shaft (See Sketches #4 and #5). Place opening roll holder and slide on machine and fasten with the two 1/2-13 x 2" Hex Head Cap Screws provided.

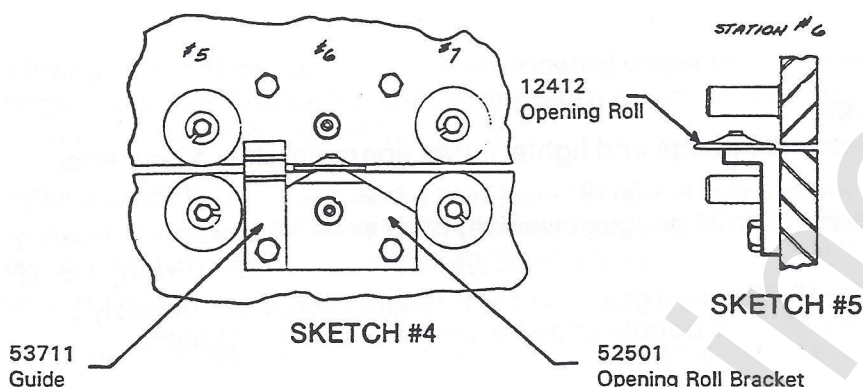

- F. Drive Cleat Auxiliary (20 gauge and lighter) uses 2-1/8" material.
 Gauge Setting2-1/8"
- G. Combination 3-in-1 rolls (capacity 22 gauge and lighter), also 2-in-1, uses approximately 1-3/4" on "T" section, 1-1/8" on standing seam and 1/2" on right angle flange.
- Gauge Setting- 3-in-1 Gauge Bar:
- | | |
|--------------------------------------|---------|
| Top Step-"T" Section | 2-1/16" |
| Middle Step-Standing Seam | 1-1/2" |
| Bottom Step-Right Angle Flange | 15/16" |
- Gauge Settings-Combination 2-in-1
- | | |
|---------------------------------|---------|
| Top Step-"T" Section | 2-1/16" |
| Bottom Step-Standing Seam | 1-1/2" |

NOTE: When the first setting is made, the other two will automatically be correct. The other two shapes can be made by placing material to the proper gauge step. The exit angle iron gauge has an adjustable bar that can be lowered to exert pressure on the material as it emerges from the rolls; thereby, straightening the finished section. See Sketch #3 on page 5.

NOTE: WHEN ADJUSTING THE EXIT GAUGE FROM THE 3-IN-1 COMBINATION, BE SURE TO SET IT TO THE "T" SECTION OR DAMAGE WILL RESULT BY MATERIAL INTERFERENCE WITH THE GAUGE BAR.

TRIPLEX CLEATFORMER

Instructions

H. Female Button Punch Snaplock (20 to 26 gauge galvanize) uses approximately 1-5/16" of material.

Gauge Setting: 2-5/16" closest to forming rolls, 2-11/32" furthest from forming rolls. Taper may be increased or decreased as required for most satisfactory results.

Upward bow can be adjusted by raising or lowering the straightener roll located between stations 8 & 9.

NOTE: To install slide between stations 2 and 3, remove existing idler gear bolt and replace with longer bolt furnished with roll set.

I. Male Button Punch Snaplock (20 to 30 gauge galvanize) uses approximately 7/16" of material.

Gauge Setting 15/16"

NOTE: Remove existing bolts between Top 4 and 5 rolls and Top 5 and 6 rolls and replace with idler bracket and bolts provided with rolls set. See Sketch #6 and #6A.

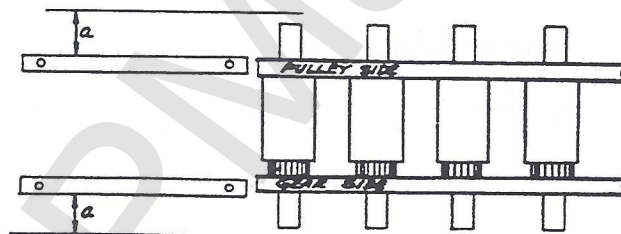
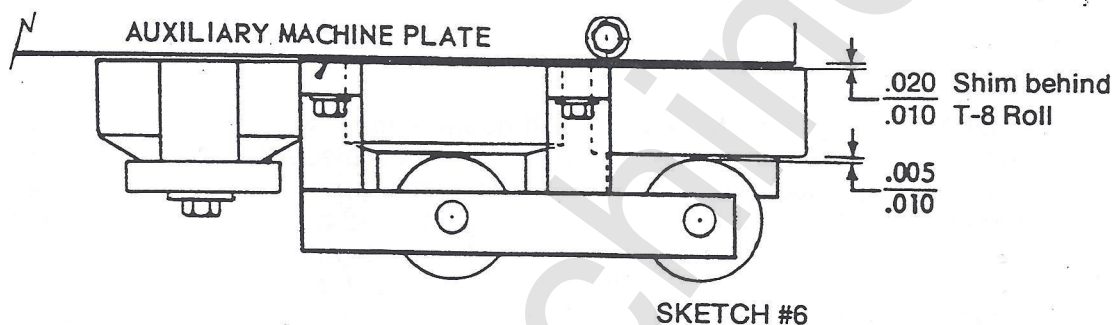

SKETCH #6A

TRIPLEX CLEATFORMER

Instructions

CAUTION: Bottom #1 roll is not fastened with retaining "C" washer. Severe damage will result to roll if instructions are not followed. See Sketch #7.

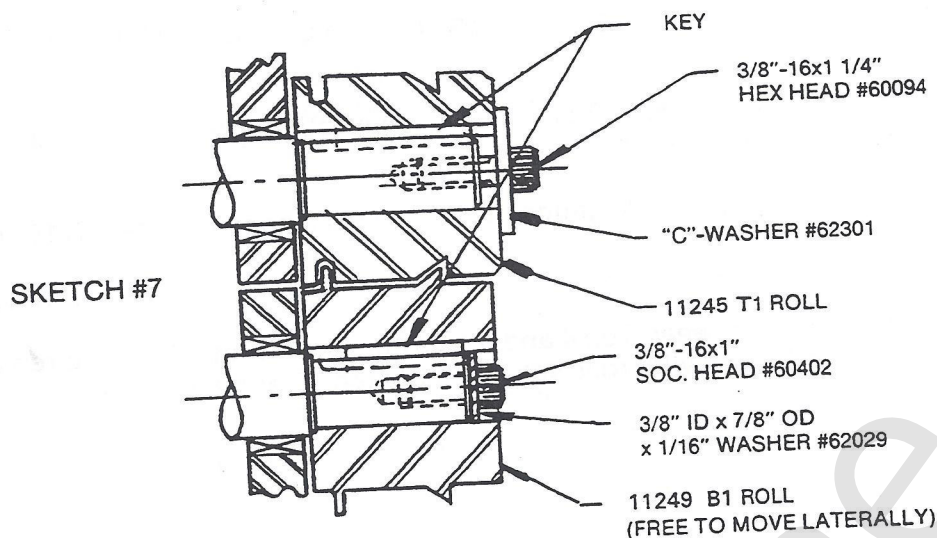

- When changing rolls, loosen the exit gauge and move it to the extreme ends of the table slots away from where the material will pass. Run a test piece of material through the rolls and stop the machine as the lead edge of the material formed reaches the end of the exit table. Set the exit gauge to the formed material—the gauge should be flush with, but not bearing against, the material unless side pressure is required for straightening. Adjustment of the pressure on the 3/8" studs that pass through the plates will effect the shape and the tendency of the material to hold the entrance gauge. It is important that, when changing rolls, all parts pertaining to each set be removed from the machine and all parts for the set to be mounted be included on assembly.
- Replace top cover and stand side plate.
- Place material against gauge bar and feed into machine.

NOTE: Roll coding is such that on similar rolls, the numbers will designate more than one station.
EXAMPLE: Combination 3-in-1 rolls have three rolls stamped LTC-2-3-B-7-8-9. These rolls are to be placed one on the bottom 7 shaft and the other two on B-8 and 9.

PREVENTATIVE MAINTENANCE:

To provide efficient, trouble free operation and to prolong the life of this tool, we suggest periodic cleaning of all rolls to remove any galvanize build-up. Galvanize build-up can be reduced to a minimum by applying a light bodied lubricant such as LOCKFORMER GALV-OFF to the forming rolls every six to eight hours of operation.

All bolts and nuts should be tightened every month or more often as required. Transmission belts should be checked for wear and proper tension periodically. Air intake vents on motor should be kept clean to insure proper ventilation.

TROUBLE CHART

WHAT TO
LOOK FOR

TROUBLE	ADJUST EXIT GAUGE.	LOOSEN THE PLATE STUDS.	TIGHTEN THE NO. 1 ZONE.	RE-SET GAUGE SETTING.	MATERIAL NOT PROPERLY SUPPORTED AS IT LEAVES THE MACHINE.	MATERIAL NOT BEING HELD TO GAUGE.	LOOSEN NO. 2 AND 3 ZONES.	TIGHTEN NO. 1 ZONE.	THREE PHASE: REVERSE TWO LINE LEADS	IN SWITCHBOX.	WIRING TO MACHINE TOO LONG, CAUSING LINE VOLTAGE DROP.	MOTOR WIRED WRONG FOR VOLTAGE USED.	LOW VOLTAGE.	LOOSE WIRING CONNECTIONS.	SWITCH CONNECTED WRONG.	POWER NOT CONNECTED.	ADJUST EXIT GAUGE.	LOOSEN THE PLATE STUDS.	TIGHTEN THE NO. 1 ZONE.	RE-SET GAUGE SETTING.	MATERIAL NOT PROPERLY SUPPORTED AS IT LEAVES THE MACHINE.	MATERIAL NOT BEING HELD TO GAUGE.	LOOSEN NO. 2 AND 3 ZONES.	TIGHTEN NO. 1 ZONE.	THREE PHASE: REVERSE TWO LINE LEADS	IN SWITCHBOX.	WIRING TO MACHINE TOO LONG, CAUSING LINE VOLTAGE DROP.	MOTOR WIRED WRONG FOR VOLTAGE USED.	LOW VOLTAGE.	LOOSE WIRING CONNECTIONS.	SWITCH CONNECTED WRONG.	POWER NOT CONNECTED.					
MOTOR WILL NOT START.								X	X	X																											
MOTOR RUNS SLOW.								X	X																												
MOTOR RUNS HOT.								X		X																											
MACHINE ROTATION REVERSED.																																					
LEAD EDGE OF MATERIAL RUNS HIGH AND EXIT END RUNS OUT.																																					
LEAD EDGE OF MATERIAL RUNS LOW AND EXIT END RUNS HIGH.																																					
"S" FOLD DIMINISHES AT EXIT END.																																					
LOCK SHOWS EXCESSIVE PRESSURE ON ENDS.																																					
MATERIAL NOT HOLDING TO FRONT GAUGE.																																					
STANDING FLANGE TOO HIGH OR LOW.																																					
MATERIAL DOES NOT HOLD TO GAUGE.																																					
180° FOLD NOT FORMING PROPERLY.																																					
MATERIAL BOWS UPWARD AND SHOWS STRETCH.																																					
LOOSE SEAM IN SNAPLOCK JOINT.																																					
EXIT END OF LOCK DAMAGED.																																					

USE NEW
NUMBER
WHEN
ORDERING
PARTS



071 TRIPLEX CLEATFORMER

Parts List

Part No.	Description	Pcs. Per Unit	Part No.	Description	Pcs. Per Unit
11141	T & B Forming Roll "S" Cleat T1 & B1	2	20221	Bottom Back Plate	1
11142	T & B Forming Roll "S" Cleat T2 & B2	2	21303	Entrance Gauge Bar	4
11143	T & B Forming Roll "S" Cleat T3 & B3	2	21305	Drive Cleat Exit Bar	1
11144	T & B Forming Roll "S" Cleat T4 & B4	2	24155	Slide (Drive Cleat)	3
11145	T & B Forming Roll "S" Cleat T5 & B5	2	24156	Slide Holder	3
11257	T & B Forming Roll "S" Cleat T7 & B7	2			
11146	T & B Forming Roll "S" Cleat T6 & B6	2	25048	Bar Jack	2
11147	T & B Forming Roll "S" Cleat T8 - B9	2	29464	Motor Base	2
11148	T & B Forming Roll "S" Cleat T9 & B9	2	31907	Sheet Slide ("S" Cleat Gear side)	1
11170	Top Forming Roll Drive Cleat T1	1	31908	Sheet Slide Roll	1
12070	Top Forming Roll Drive Cleat T2, T3, & T4	3	37000	Grease Fit Shim	2
12071	Top Forming Roll Drive Cleat T5	1	42001	Lube Bolt	1
12072	Top Forming Roll Drive Cleat T6	1	58512	Stand	1
12073	Top Forming Roll Drive Cleat T7	1	51041	Cover	1
12074	Top Forming Roll Drive Cleat T8	1	51900	Fiber Gear Assembly	1
12075	Top Forming Roll Drive Cleat T9	1	53304	Exit Gauge ("S" Cleat)	1
12076	Bottom Forming Roll Drive Cleat B1	1	60047	5/16-18 x 3/4 HHCS	5
12077	Bottom Forming Roll Drive Cleat B2	1	60052	5/16-18 x 1 HHCS	1
12078	Bottom Forming Roll Drive Cleat B3	1	60090	3/8-16 x 3/4 HHCS	4
12079	Bottom Forming Roll Drive Cleat B4, B5 & B6	3	60097	3/8-16 x 1-3/4 HHCS	4
12080	Bottom Forming Roll Drive Cleat B7, B8 & B9	3	60098	3/8-16 x 2 HHCS	2
13284	Roll Shafts	18	60164	1/2-13 x 5 HHCS	21
13302	1st Drive Shaft	1	60166	1/2-13 x 3-1/2 HHCS	4
13304	2nd Drive Shaft	1	60228	1/2-13 x 1 3/4 HHCS	29
13406	3rd Drive Shaft	1	60302	1/4-20 x 5/8 SHCS	10
13505	Plain Spacer "S" Cleat 1-1/4" x 5-1/64"	17	60450	1/2-13 x 1 SHCS	1
13605	Idler Spacer	7	60551	1/4-20 x 1/2 RHMS	5
13657	Main Idler Spacer	1	60575	10-24 x 3/8 RHMS	4
13701	Plain Spacer Drive Cleat 1-1/4" x 2-21/32"	21	60593	10-32 x 7/16 FHMS	2
13703	Plain Spacer Drive Cleat 1-1/2" x 3/8"	17	60680	3/8-16 x 3/8 SSS	2
13704	Roll Spacer Drive Cleat 1-3/8" x 17/32" 2/keyway	4	60795	4 x 3/16 Drive Screws TP-U	8
14160	Driven Gear	18	60875	3/8-16 x 1 CB	4
14161	Idler Gear (Needs 1-66090 Bearing)	7	60876	3/8-16 x 1-1/4 CB	4
14162	Main Idler Gear (Needs 2-66100 Bearings)	1	60877	3/8-16 x 1-3/4 CB	4
14301	Driven Gear Main	1	60881	3/8-16 x 1-1/2 CB	8
14640	Collar	1	60954	1/2-13 x 1 FH Screws	6
14661	Thrust Collar	2	60994	Screw	1
14930	Hex Spacer Lube	1	61040	10-24 Hex Nut	4
20218	Top Flate	9	61101	5/16-18 Hex Nut Heavy SF	1
20219	Bottom Front Plate	1	61120	3/8-16 Hex Nut Heavy SF	14
20220	Bottom Center Plate	1	61122	3/8-16 Hex Nut Fin	26
			61160	1/2-13 Hex Nut Heavy SF	6

USE NEW
NUMBER
WHEN ORDERING
PARTS



071 TRIPLEX CLEATFORMER

Parts List

New Part No.	Description	Pcs. Per Unit	New Part No.	Description	Pcs Per Unit
61300	3/8-16 Jam Nut SF	18			
62026	3/8 x .052 Washers	4			
62027	3/8 x .082 Washers	18			
62029	3/8 x 1/16 Washer	50			
62123	1 x .020 Washer	36			
62340	3/8 Spring Washer	216			
62363	3/8 Lock Washer	12			
62364	1/2 Lock Washer	43			
62402	15 Woodruff Key	57			
62518	5160-98 Retaining Ring	18			
62551	3/8-16 x 6-1/2 Stud Hold Down	18			
62633	3/8 x 1 Dowel	12			
66090	Bearing (B1416 Torr)	7			
66100	Bearing (B1612) Torr)	56			
66111	Bearing (HJ 162412 Torr)	6			
66320	Bearing (NTA 1625 Torr)	2			
66321	Bearing (TRC 1625 Race)	2			
66422	Bearing (TT1503-2 Thrust)	7			
66425	Bearing (TT1709-1 Thrust)	78			
66600	Connector (886L Female Coupling)	7			
66610	Half Union (888L)	7			
66640	1610 Grease Fittings	8			
66650	Angle Body	1			
66700	Plastic Tubes 4 pcs.-14" & 3 pcs.-18"	110"			
70052	V Belt 5L480	2			
70421	Sheave 2BK32 x 1	1			
70442	Sheave 2BK45 x 1-1/8	1			
80080	5 HP 3 Phase 60 Cycle 1800 RPM (184)	1			
80103	Motor Control (609 Bow)	1			
80423	BX. Cable 12-3 x 58"	1			
80483	BX. Connector 3/8	1			
80484	BX. Connector 3/4	1			
80601	Ring TNG Terminal	3			
80928	Back Enclosure	1			
82254	W54 Heaters	3			
85178	Lockformer Logo	1			

MAY ADD .020 SPACER BEHIND B-6 TO CONTROL HEM.
 FOR MOUNTING INSTRUCTIONS SEE OPERATION MANUAL FOR C-8900 SUPER-SPEED CLEATFORMER

NOTE: THIS SET STAMPED BLF SEE NOTE (C)

ENTRANCE HOLD DOWN A-24-BLF-1F SEE DRAWING (B) BELOW WITH NOTE (B) FEMALE AUX. ROLLS

13503 - SPACERS (12) REQ'D

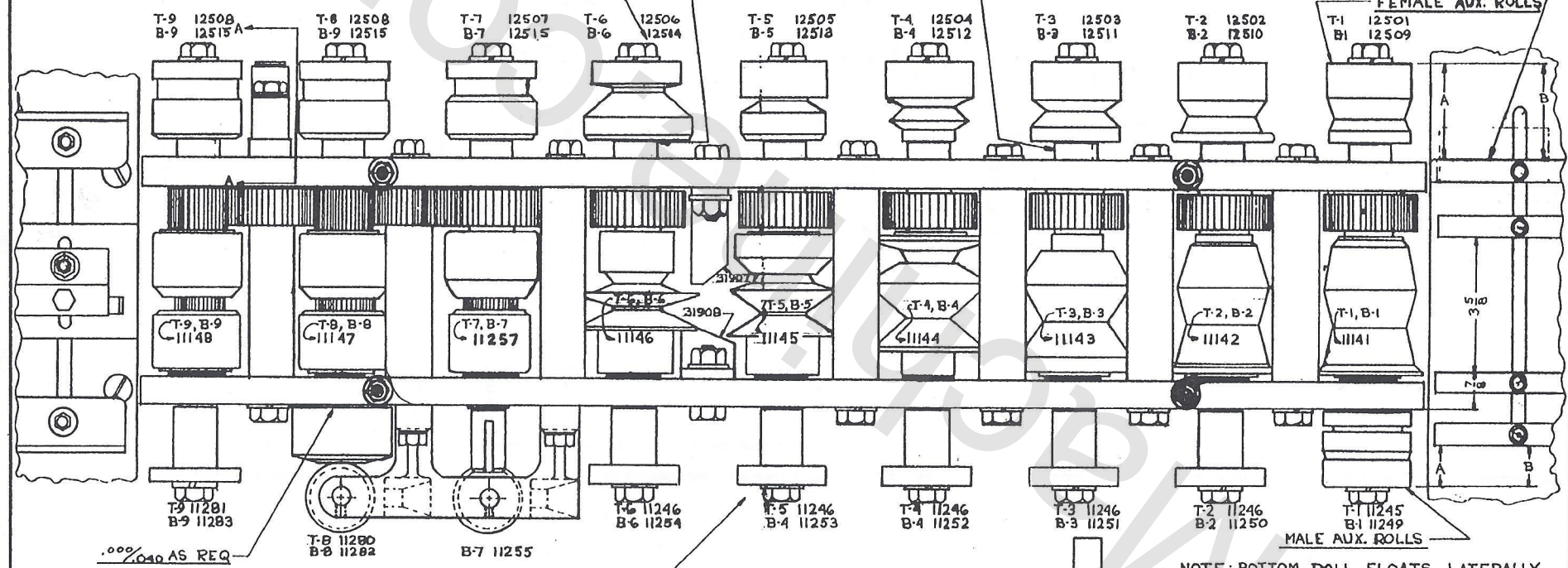

NOTE: THIS SET STAMPED BLM

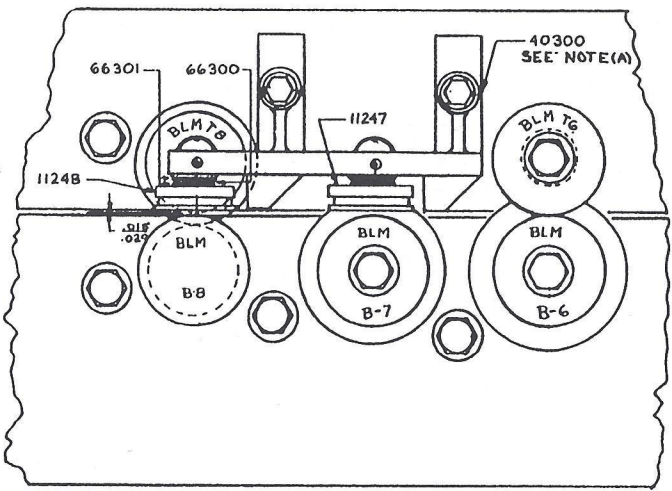

MOVE ROLL UP OR DOWN FOR FINAL ADJUSTMENT FOR STRAIGHTNESS
 NOTE (A) LEFT HAND INSTALLATION AS SHOWN RIGHT HAND INSTALLATION REQUIRES PART 40290

NOTE (C) RIGHT HAND FEMALE A-24 BLF ROLLS SHOWN INSTALLATION THE SAME FOR LEFT HAND
 NOTE (B) SHOWING RIGHT HAND ASSY. FOR LEFT HAND ASSY. INVERT.

NOTE: BOTTOM ROLL FLOATS Laterally & IS NOT HELD BY RETAINING BOLT ROLL IS DRIVEN BY KEY & KEY IS RETAINED BY SMALLER DIAMETER WASHER 3/4 O.D. AND BOLT TOP ROLL MAY BE SHIMMED OUT TO REPOSITION PUNCH UP OR DOWN

MALE AUXILIARY ROLLS
 A. EDGE OF GAUGE CLOSEST TO ROLLS 1/2"
 B. EDGE OF GAUGE FURTHEST FROM ROLLS 1"
 FEMALE AUXILIARY ROLLS
 A. EDGE OF GAUGE CLOSEST TO ROLLS 2 1/2"
 B. EDGE OF GAUGE FURTHEST FROM ROLLS 2 1/2"
 FORM # 110
 INSTALLATION 24GA BLF THE SAME ON TRIPLEX MACHINE

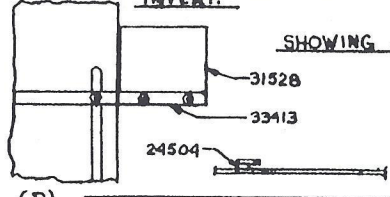

(B) FRACTIONAL DECIMAL ANG. TOL.

THE LOCKFORMER CO. 3111 OGDEN AVE. LT ROAD LIBEL, ILLINOIS 60838		PART NUMBER 59000	
MACHINE CLEATFORMER 89		PART NAME 24GA. BUTTON LOCK AUX ROLLS	
DRAWN BY P.D. VITO	CHECKED BY	DATE 9-28-73	REVISIONS

DRAWING No. 59070

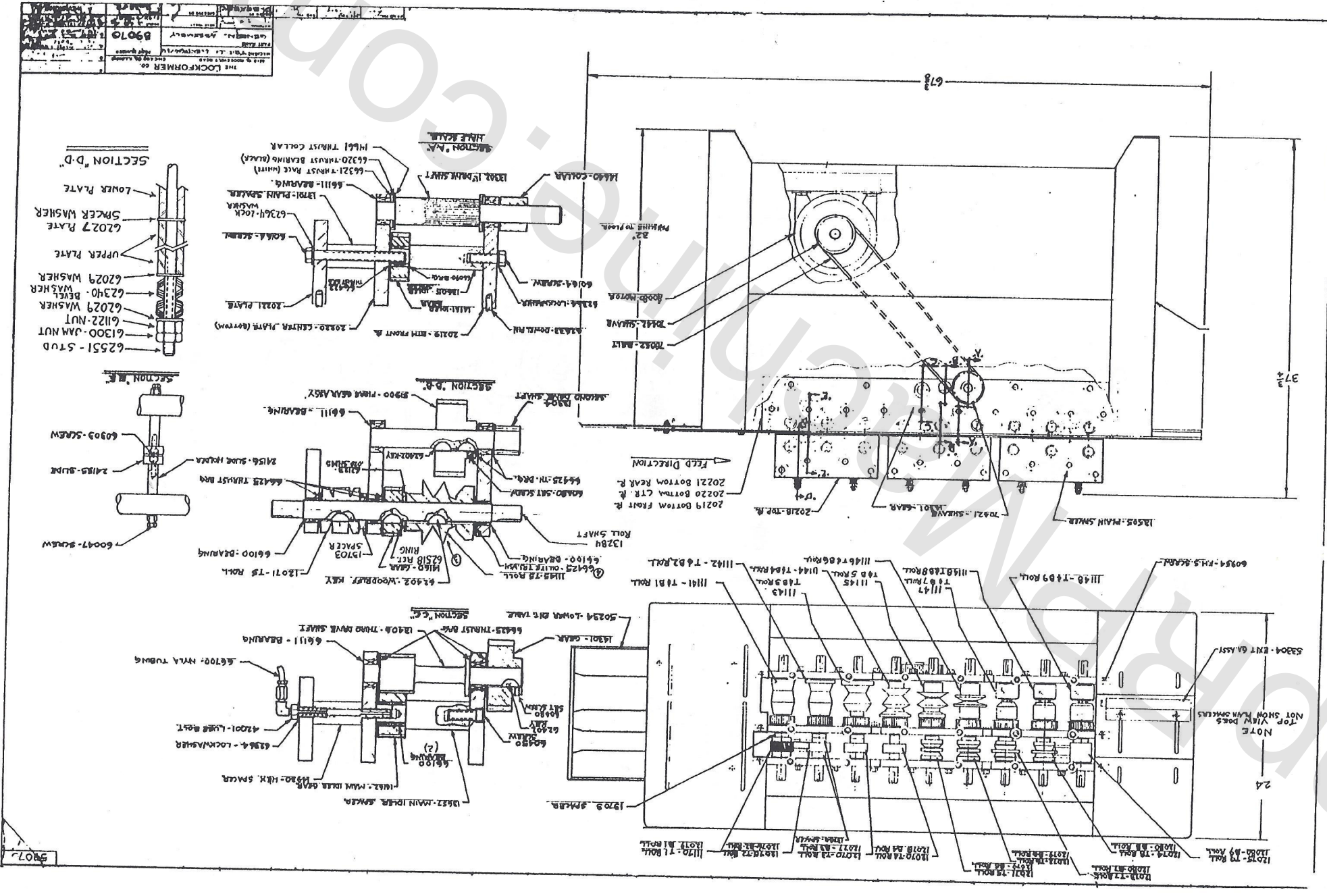

THE LOCKFORMER CO.
 5000 W. 15th St. - Los Angeles, Calif.
 PART NO. 59070
 DATE: 11-10-38
 BY: J. W. ...

DRAWING NO. 59134

59134

Form No. 98

NOTE C ③
SAME GAUGE BARS USED ON RIGHT
HAND INSTALLATION AS PER NOTE A

INVERT ASSEMBLY

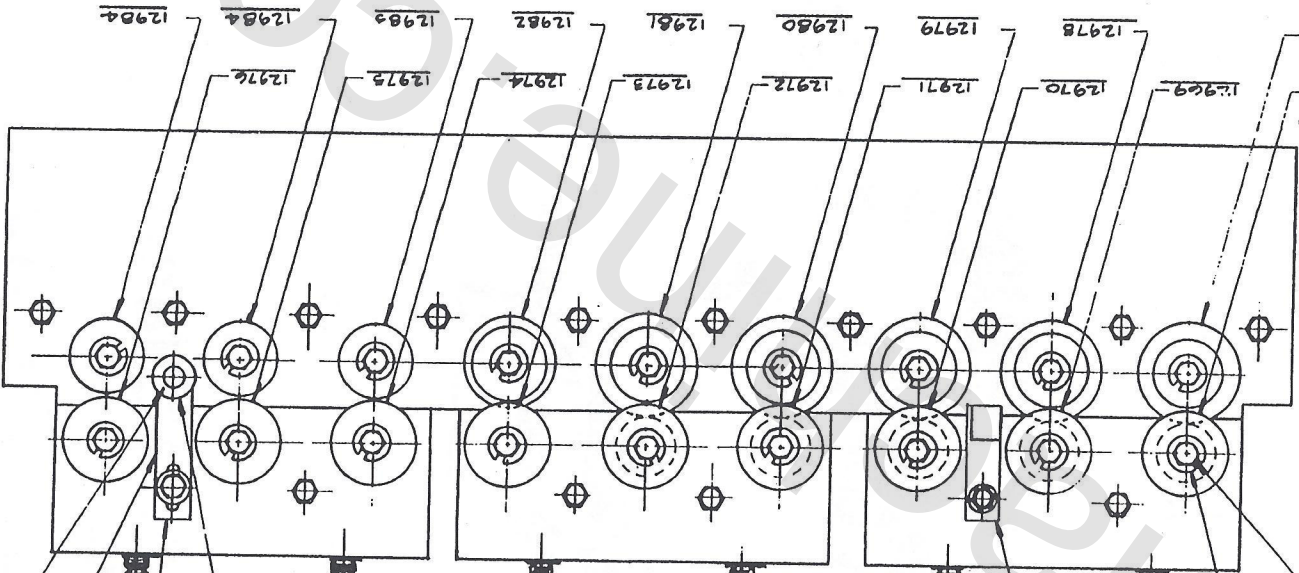
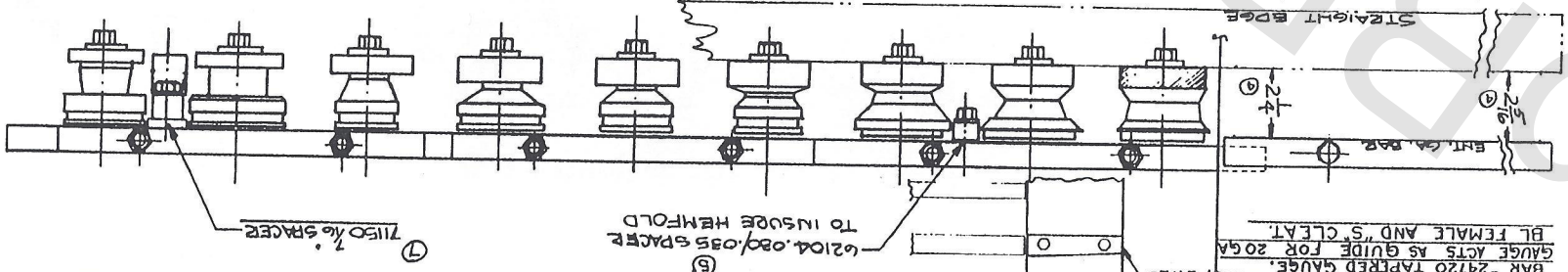
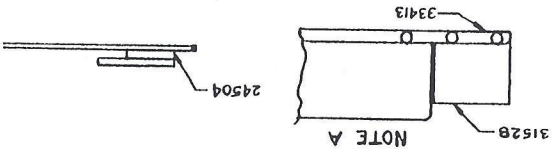

For R.H. MOUNTING - 12970
For L.H. MOUNTING - 12971

DATE	6-2-72	DESIGNED BY	J. BARBER
SCALE	3/8"	CHECKED BY	
MATERIAL		APPROVED BY	
PART NAME	COLL ARRANGEMENT	PART NO.	59134
MACHINE	TRIPLEX CHEATORMAR		
THE LOCKFORMER CO. 711 OGDEN AVE. LY ROAD Lisle, ILLINOIS 60532			
REVISIONS			
NO.	DATE	DESCRIPTION	BY
1	11-13-73	ADDED NOTES A, B, C	JD
2	11-13-73	ADDED 62104	JD
3	11-13-73	ADDED 14504	JD
4	11-13-73	ADDED 12974	JD
5	11-13-73	ADDED 12975	JD
6	11-13-73	ADDED 12976	JD
7	11-13-73	ADDED 12977	JD
8	11-13-73	ADDED 12978	JD
9	11-13-73	ADDED 12979	JD
10	11-13-73	ADDED 12980	JD
11	11-13-73	ADDED 12981	JD
12	11-13-73	ADDED 12982	JD
13	11-13-73	ADDED 12983	JD
14	11-13-73	ADDED 12984	JD

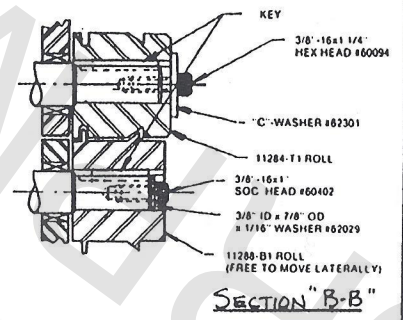
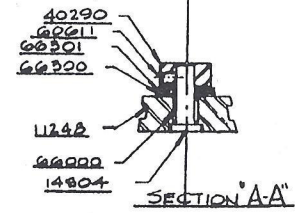
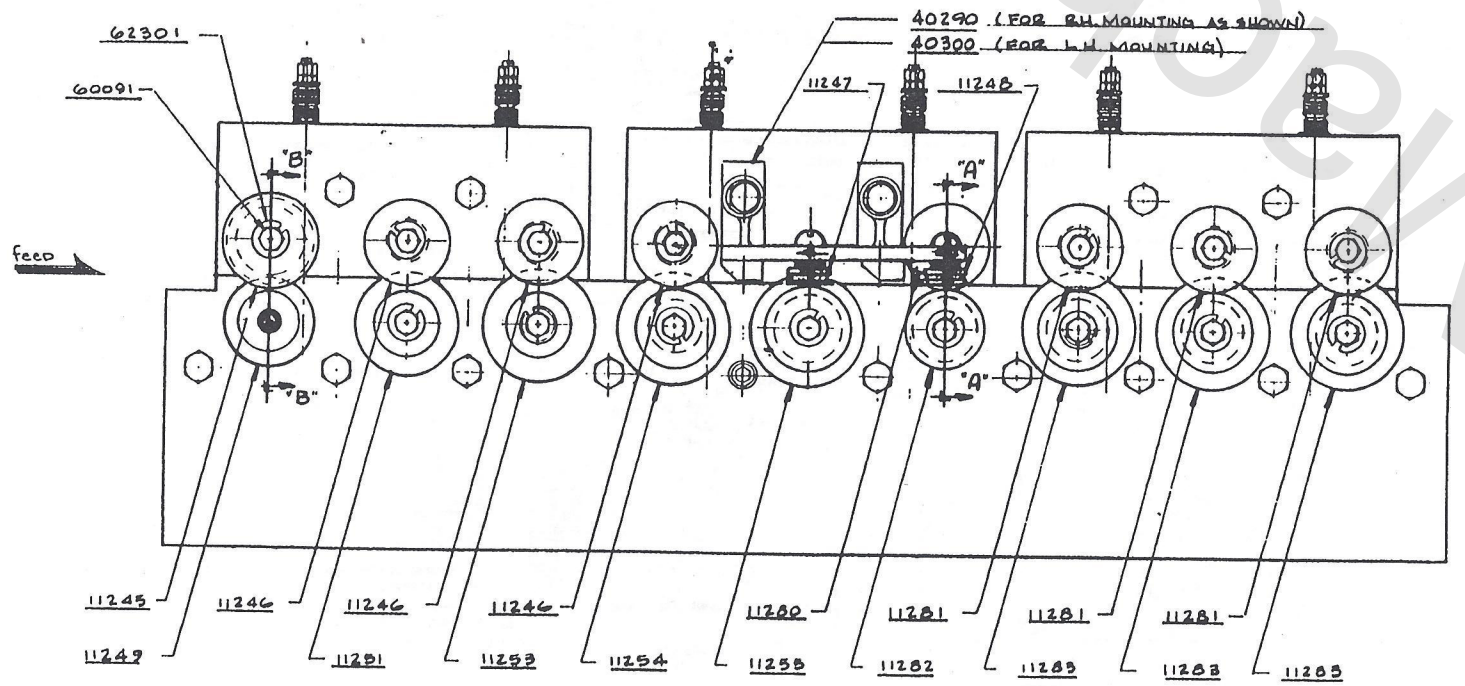
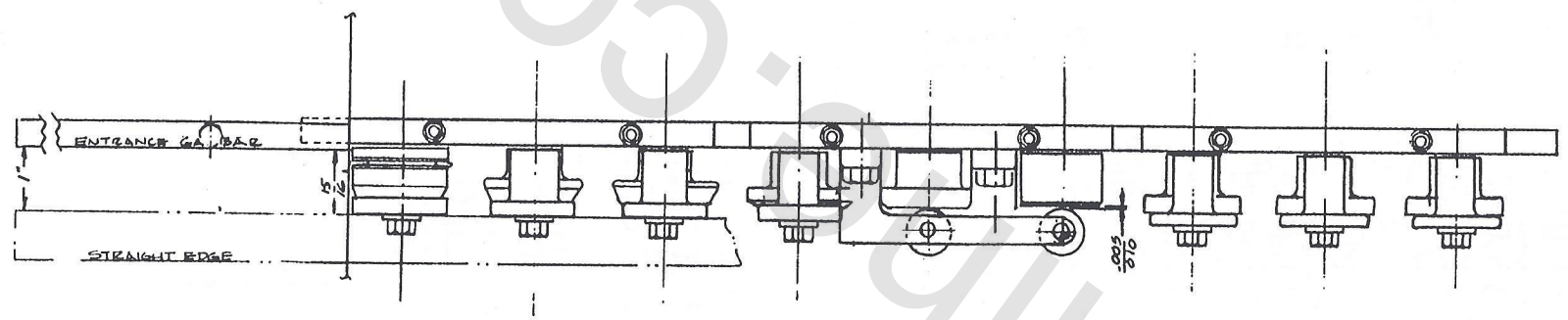

Form No. 97

THE LOCKFORMER CO.		
711 OGDEN AVE. LT ROAD		LIBLE, ILLINOIS 60883
MACHINE	TRIPLEX CLEARFORMER	PART NUMBER
PART NAME	Roll Arrangement	59133
PART NAME	Button Lock Male	
MATERIAL	HEAT TREAT	SCALE 3/8
DRAWN BY	D. PRABEC	CHECKED BY
		DATE 5-31-72
FRAS. TOL.	SEC. TOL.	ANG. TOL.
		REVISIONS

DRAWING No. 59134

59134

Form No. 98

NOTE A
LEFT HAND INSTALLATION WITH SLITTER USE
ENTRANCE GAUGE ASSEMBLY.

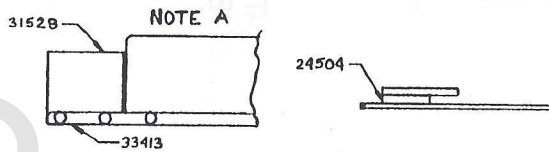

NOTE C
SAME GAUGE BARS USED ON RIGHT
HAND INSTALLATION AS PER NOTE A
INVERT ASSEMBLY.

NOTE B
LEFT HAND INSTALLATION LESS
SLITTER USE COMBINATION GAUGE
BAR *24720 TAPERED GAUGE.
GAUGE ACTS AS GUIDE FOR 20GA
BL FEMALE AND "S" CLEAT.

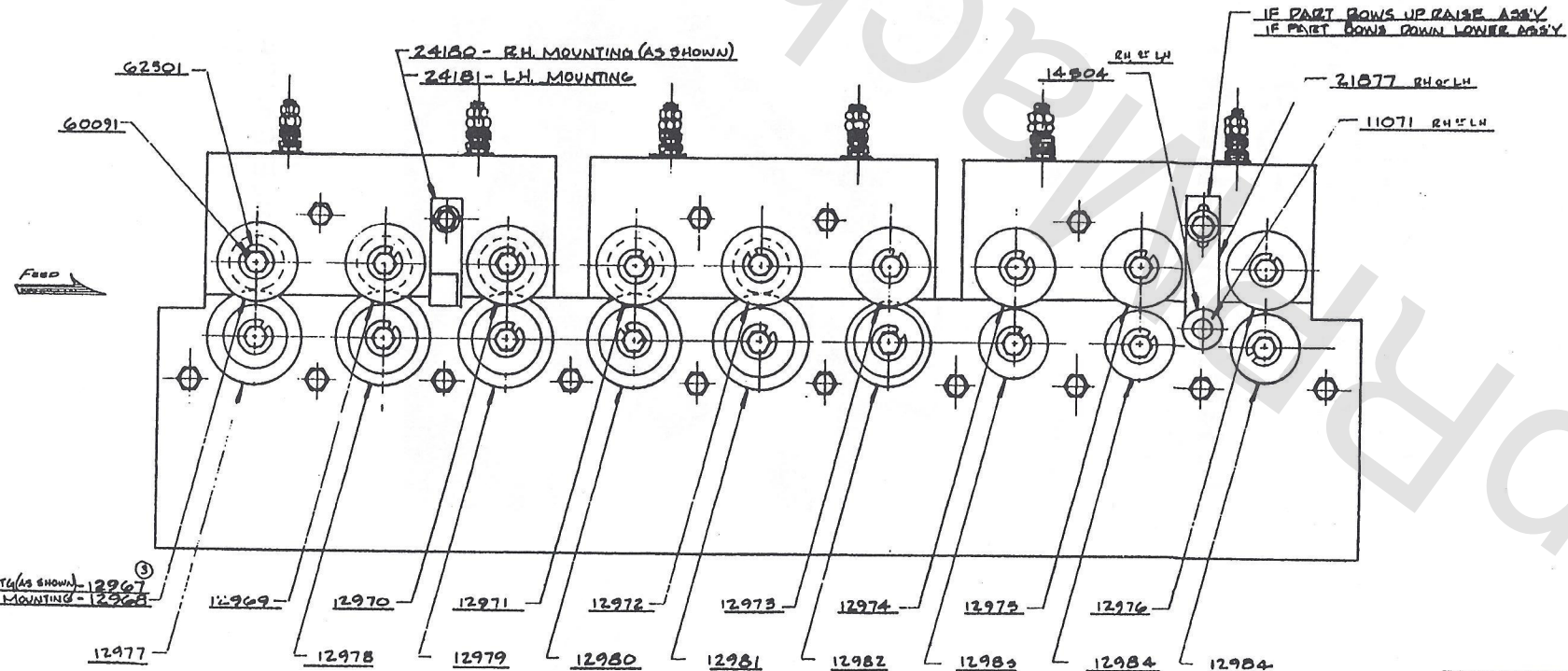
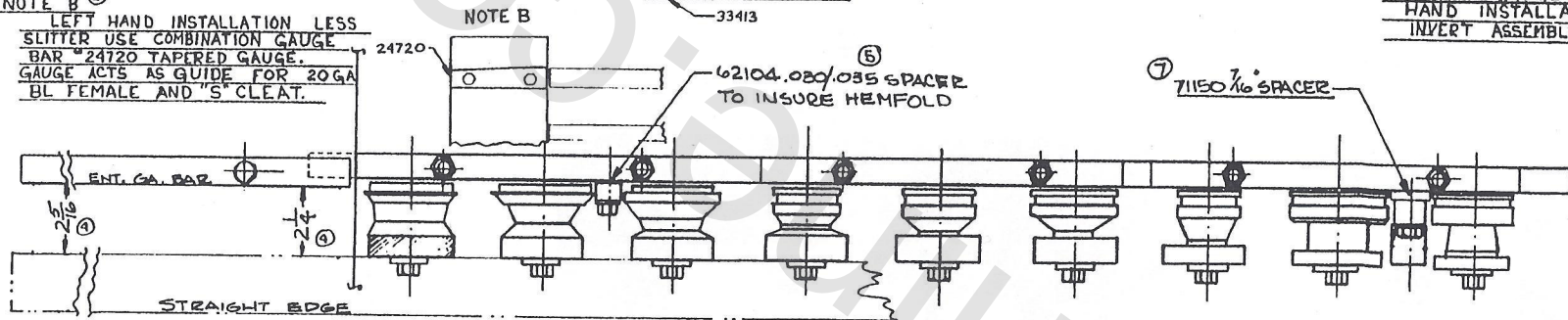

For RH. MTD (AS SHOWN) - 12967
For L.H. MOUNTING - 12968

IF PART BOWS UP RAISE ASSEMBLY
IF PART BOWS DOWN LOWER ASSEMBLY

THE LOCKFORMER CO. 711 OGDEN AVE. LY ROAD LITTLE, ILLINOIS 60538		171150 WAS 13503 2-13-73 RSM
MACHINE TRIPLEX CLEAT FORMER	PART NUMBER	*ADDED 13503 RSM 10/1/74
PART NAME ROLL ARRANGEMENT BUTTON LOCK FEMALE	59134	*ADDED 62104 10/7/74
MATERIAL	SCALE 5/8	21877 WAS 21877 11-27-74 21877 WAS 21877 11-27-74 21877 WAS 21877 11-27-74 21877 WAS 21877 11-27-74
DATE 6-2-72	REVISIONS	*ADDED NOTES A, B, C 11-13-73 D.D.

Operating Instructions

“S” AND DRIVE CLEAT CUTTER ATTACHMENT FOR TRIPLEX CLEATFORMER

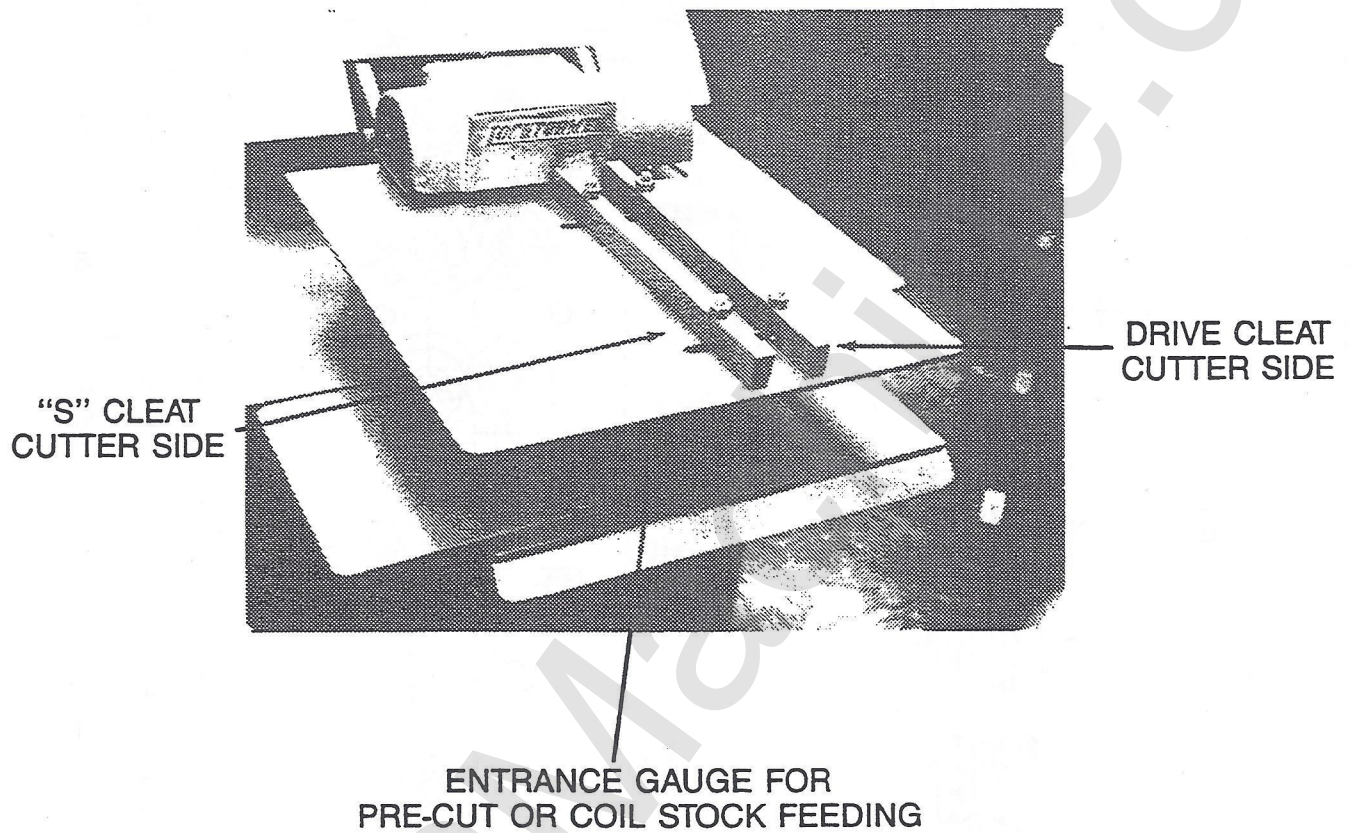

"S" AND DRIVE CLEAT CUTTER ATTACHMENT

Installation Instructions

Maximum Capacity of Unit: 22 Ga. Galv. (.0350" Material)
Minimum Length of Cleat to be cut: 12" minimum.

1. Set slitting attachment on entrance table so that the spur gear of the attachment meshes with the gear of the No. 1 forming roll. Refer to Sketch No. 1 or set-up.
2. By placing the template (furnished) across the slitter casting; thinnest side against casting and widest side against machine plate; leave an approximate $1/32$ " clearance between machine plate and template. Then bolt in place per Sketch No. 1. A slight adjustment to the left or right may be required to provide the desired size of cut.

NOTE: Template edge must be parallel to machine plate and slitter attachment casting.

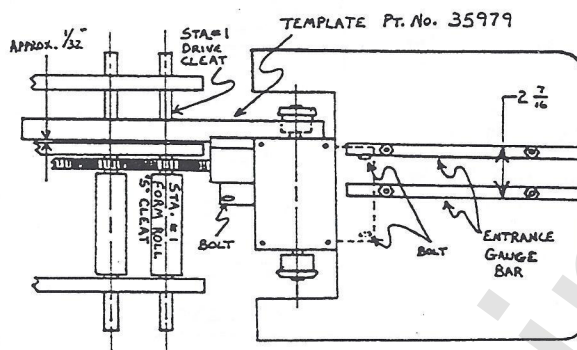

Alternate Set-Up Procedure:

Place straight edge across the back of the slitter attachment casting and measure $7/32$ " from straight edge to machine plate. Take measurements at least 12" apart to insure slitter attachment is parallel to machine plate.

NOTE: Entrance gauge bar is factory set and should not need adjustment. Setting is given for reference only.

3. Replace machine cover.

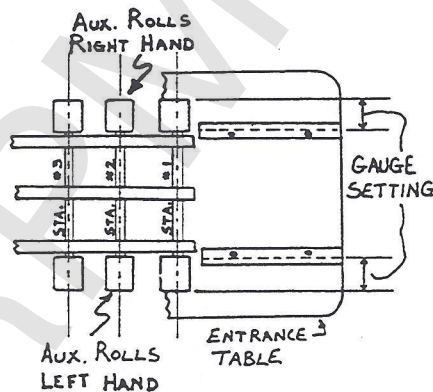

SKETCH #2



"S" AND DRIVE CLEAT CUTTER ATTACHMENT

Entrance Gauge Table Settings

ENTRANCE GAUGE TABLE SETTINGS

For aligning Gauge bars refer to Drawing No. 2. for Dimensions and Settings.

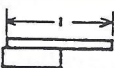
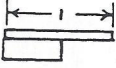
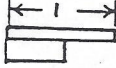
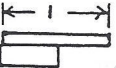
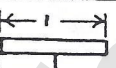
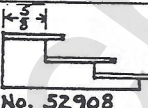
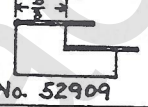
CHART 1

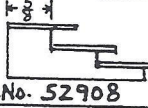
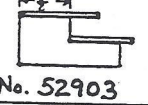
AUX. ROLL SETS	LOCATION	MACHINE	ENTRANCE GAUGE TO BE USED	ENTRANCE GAUGE SETTING FROM EDGE OF ROLL
5/16 Pittsburgh	Right Hand and Left Hand Auxiliary	Triplex Cleatformer	 Pt.No. 52907	1-11/16" 1-3/4"
Type L & S Double Seam	Right Hand and Left Hand Auxiliary	Triplex Cleatformer	 Pt.No. 52907	Type S 1-1/8" Type L 1-5/16"
Standing Seam	Right Hand and Left Hand Auxiliary	Triplex Cleatformer	 Pt.No. 52907	2"
24 Female Button Lock	Right Hand Auxiliary	Triplex Cleatformer	 Pt.No. 52907	2-3/32" 2-5/32"
Drive Cleat	Right Hand Auxiliary	Triplex Cleatformer	 Pt.No. 52907	2-1/8"
3 in 1	Right Hand Auxiliary	Triplex Cleatformer	 Pt.No. 52908	Top Step 2-1/16" Middle Step 1-1/2" Bottom Step 15/16"
2 in 1	Right Hand Auxiliary	Triplex Cleatformer	 Pt.No. 52909	Top Step 2-1/16" Bottom Step 1-1/2"
24 Female Button Lock	Left Hand Auxiliary	Triplex Cleatformer	 Pt.No. 52907	2-3/32" 2-5/32"
Drive Cleat	Left Hand Auxiliary	Triplex Cleatformer	 Pt.No. 52907	2-1/8"
3 in 1	Left Hand Auxiliary	Triplex Cleatformer	 Pt.No. 52908	Top Step 2-1/16" Middle Step 1-1/2" Bottom, Step 15/16"
2 in 1	Left Hand Auxiliary	Triplex Cleatformer	 Pt.No. 52903	Top Step 2-1/16" Bottom Step 1-1/2"

"S" AND DRIVE CLEAT CUTTER ATTACHMENT

Operations Instructions

1. Check settings and make sure all mounting bolts are tight.
2. Start machine and place the material against the entrance gauge bar of the slitting attachment and feed the stock into the slitting rolls. The slit material will automatically deflect downward to the forming roll while the piece in the operator's hand will deflect upward to clear the machine. The slitter will cut straight as long as the material which has not gone thru the slitting rolls is held against the entrance gauge bar.

NOTE: WHEN RUNNING LONG SHEETS IT IS ADVISABLE THAT THE SHEET BE SUPPORTED AT APPROXIMATELY THE SAME HEIGHT AS THE SLITTING ATTACHMENT ENTRANCE TABLE.

ADJUSTMENT

The slitter is properly adjusted and tested before shipment. Should the gauge accidentally become misaligned, refer to installation instructions paragraph 2.

If the cleat runs out, or if material distribution is not correct, check the mounting of the attachment making sure the unit is mounted parallel to the machine side plates and settings are correct.

When the slitting rolls need resharpening remove the bottom roll and grind it on the O.D. to remove any nicks and present a clear sharp edge. The top roll has two cutting edges, when the resharpened lower roll is reinstalled, merely reverse the side of the roll presenting a new cutting edge. When ordering parts for this unit, please SPECIFY the SERIAL NUMBER stamped on the name plate.

CAUTION: Machine will jam if pieces less than 12" are used.

In case of jam-up, remove sheet deflector casting 56574 and remove material from unit.

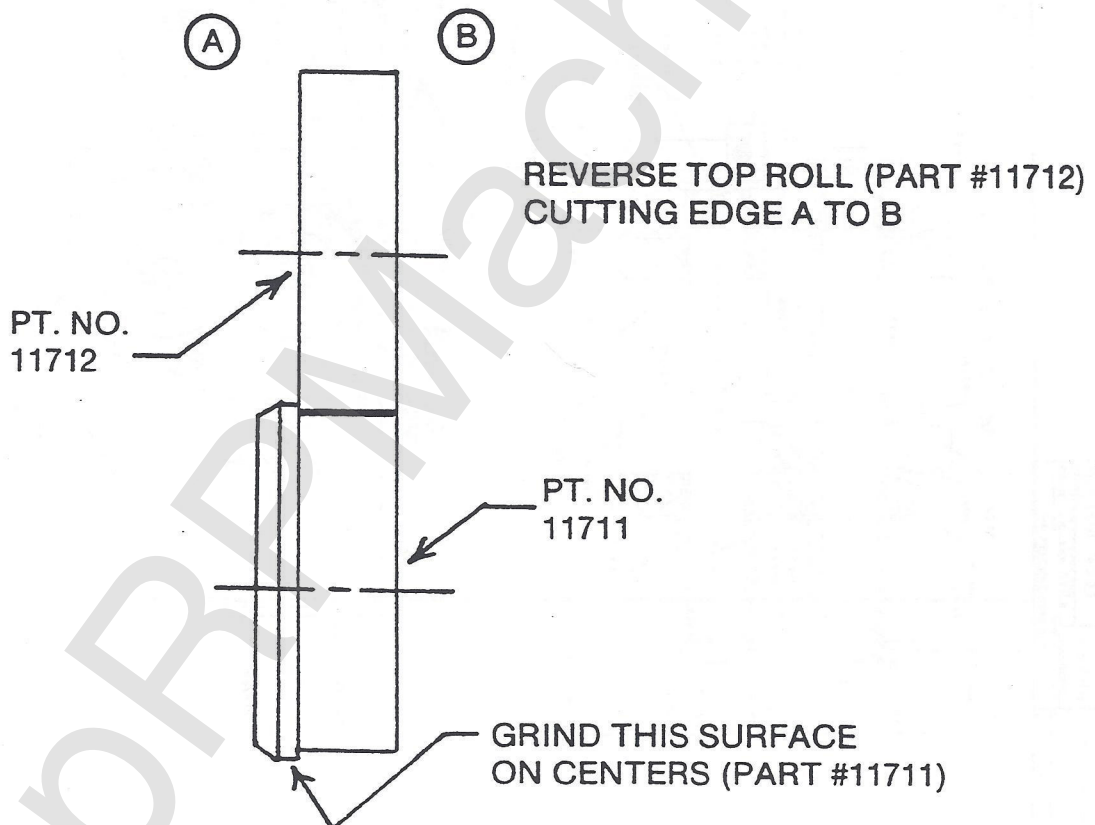

DRAWING NO. 59588

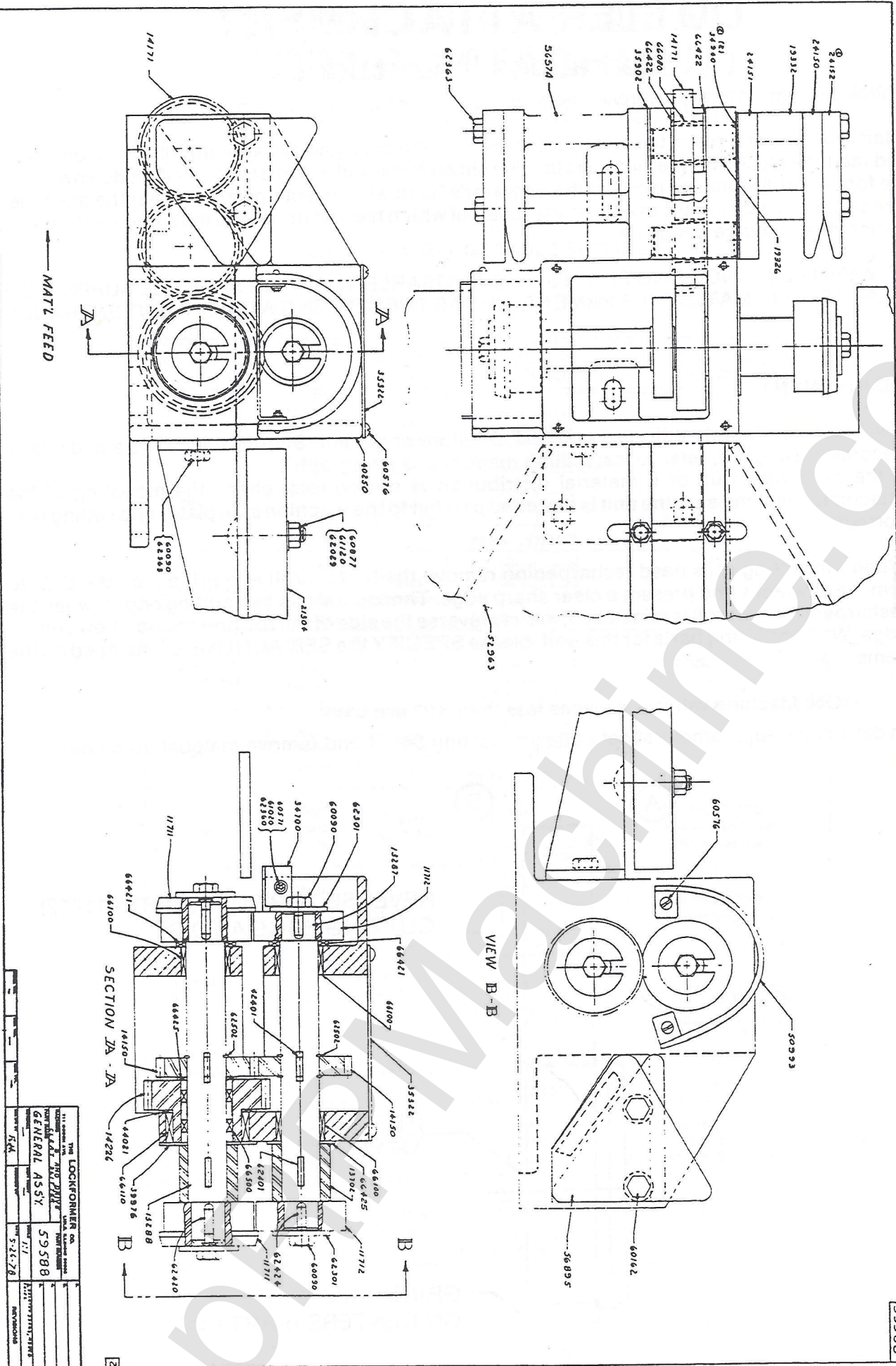

59588

THE LOCKFORMER CO. 111 S. GARDNER ST. PORTLAND, ORE.	
GENERAL ASSY. 59588	5-25-28
DRAWN BY CHECKED BY APPROVED BY	DATE

DRAWING Form 140

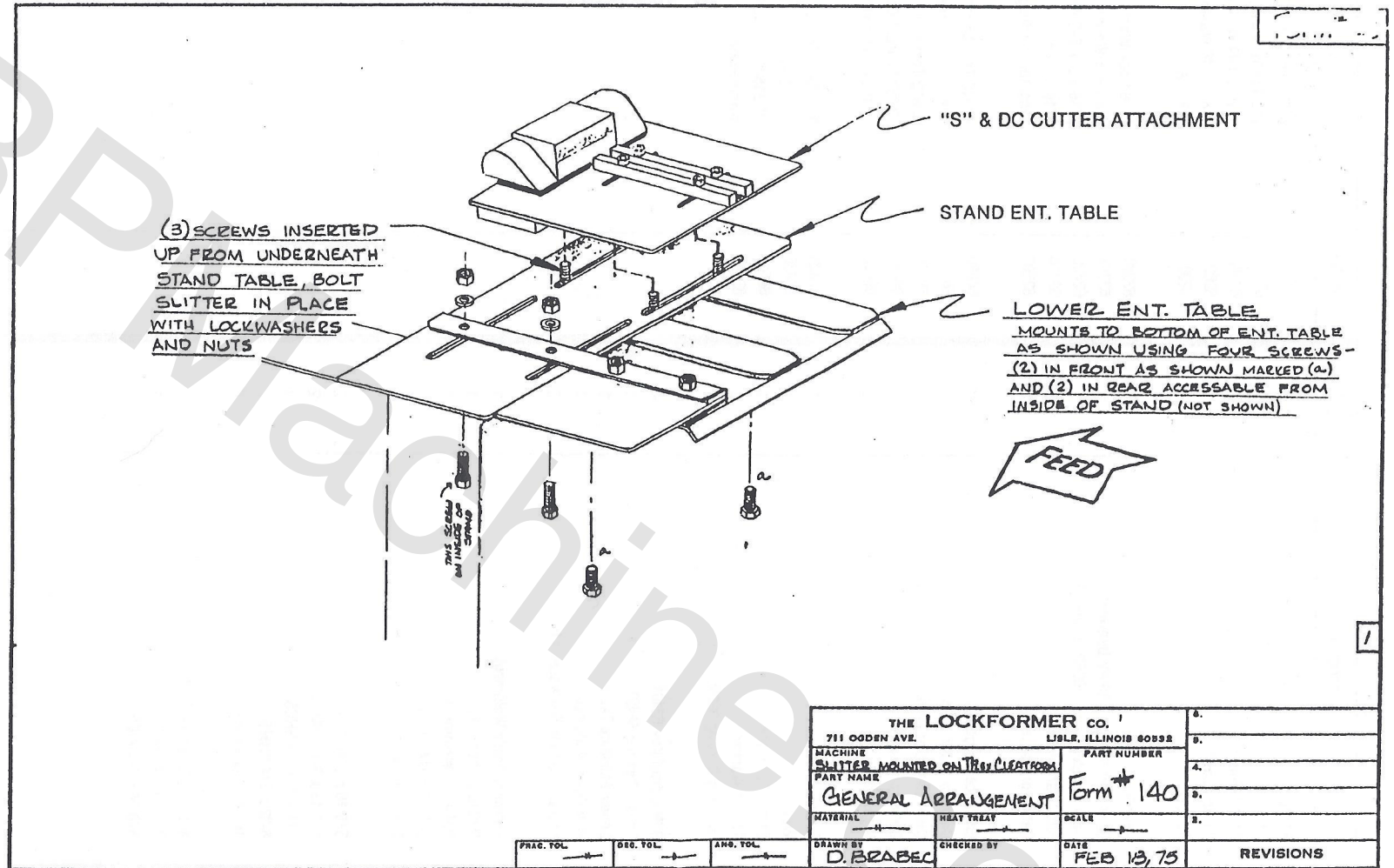

THE LOCKFORMER CO. 1 711 OGDEN AVE. LISLE, ILLINOIS 60532			6.
MACHINE SLITTER MOUNTED ON TREE CUTTER			7.
PART NAME GENERAL ARRANGEMENT		PART NUMBER Form # 140	8.
MATERIAL N	HEAT TREAT —	SCALE —	9.
FRAC. TOL. —	DEC. TOL. —	ANG. TOL. —	10.
DRAWN BY D. BRABEC	CHECKED BY	DATE FEB 13, 75	REVISIONS

"S" AND DRIVE CLEAT CUTTER ATTACHMENT

USE NEW
NUMBER
WHEN ORDERING
PARTS



023 Combination/Parts List

Part No.	Description	Pcs. Per Unit	Part No.	Description	Pcs. Per Unit
11711	B1 Roll	2	61020	8-32 Hex Nuts	2
11712	T1 Roll	2	61120	3/8-16 HN Heavy	7
13287	T1 Roll Shaft	1	62002	3/16 x .049 Washer	2
13288	B1 Roll Shaft	1	62029	3/8 x 1/16 Washer	7
13702	Spacer	2	62301	3/8 C Washer	4
14150	Gear Driven	2	62360	3/16 Lock Washer	2
14171	Gear Idler (Needs 1-66080 Bearing)	2	62363	3/8 Lock Washer	7
14226	Gear Clutch (Needs 1-66500 Bearing)	1	62420	3/16 Sq. x 5/8 Key	2
19326	Idle Gear Stud	2	62424	3/16 Sq. Key 1/2	2
19332	Deflector Spacer	2	62502	5100-100 Ret Ring	3
21304	Entrance Gauge Bar	2	66080	B1412 Torr Bearing	2
24151	Deflector Plate Back	1	66100	B1612 Torr Bearing	3
24152	Outer Deflector Plate	1	66110	B2812 Torr Bearing	1
34700	Deflector Guard	1	66421	TT1502 Thrust Bearing	2
34960	Wear Plate	2	66422	TT1503-2 Thrust Bearing	4
35322	Cover Plate	1	66425	TT1709-1 Thrust Bearing	1
35902	Wear Plate	1	66430	TT1502-2 Thrust Bearing	1
35979	Slitter Template	1	66500	RCB162117 Clutch Bearing	1
39976	Thrust Washer	1	85169	Name Plate	1
40250	Housing Casting 88250	1			
42401	9 Woodruff Key 62401	4			
44021	Thrust Bearing 66427	1			
50234	Lower Entrance Table	1			
50993	Roll Cover Weldment	1			
52907	Entrance Gauge Bar Assembly	2			
52963	Entrance Table Weldment	1			
56574	Deflector Assembly	1			
56895	Deflector Weldment	1			
60090	3/8-16 x 3/4 HHCS	5			
60093	3/8-16 x 1 HHCS	2			
60102	3/8-16 x 5 HHCS	2			
60162	1/2-13 x 3-1/2 HHCS	2			
60498	5/16-18 x 3/8 SHCS	1			
60571	8-32 x 3/4 RHMS	2			
60576	10-24 x 1/2 RHMS	4			
60795	4 x 3/16 Dr Screw TP-U	2			
60876	3/8-16 x 1-1/4 CB	1			
60877	3/8-16 x 1-3/4 CB	1			