

flagler

Designers and Manufacturers of Sheet Metal Roll Forming Machinery

24 Junior Pittsburgh Machine

Operating Instructions and Parts List



OUR NEW
AREA CODE IS
586

56513 Precision Drive., Chesterfield, MI 48051

Phone (810) 749-6300

Fax (810) 749-6363

Operating Instructions

A feed gauge is located on the entrance end of the machine. Place the metal (24 Ga. Max) against this gauge and slide it into the forming head of the machine. The machine has been tested and adjusted at the factory, however to compensate for variations in material, it is necessary to make certain adjustments from time to time.

1. If the material pulls away from the feed gage, tighten the hold down stud at the entrance end until it corrects itself.
2. If the material slips or sticks upon exiting the forming head, tighten the hold down stud at the exit end slightly.

In feeding long sheets through the machine, be sure that they are flat against the table as well as against the feed gage, especially when the metal enters the roller dies.

COVER MUST BE IN PLACE WHEN IN OPERATION

CAUTION

Burrs and jagged edges should be flattened out so that they do not hit the opening roll, which might cause breakage. If the edge of the sheet to be formed is kept smooth, the blade-edged roll, which holds open the pocket in the Pittsburgh lock, will not chip or break.

LUBRICATION

Due to the low speed of this machine, the shafts do not require lubrication. However if galvanized metal is to be used, the roller dies must be periodically lubricated to remove any galvanized buildup. Specifically, the opening roll should be kept free of any type of buildup. This can be accomplished using Flagler Lubaroll. Also, the motor should be oiled periodically and not less than three times a year.

SPECIFICATIONS

Length 30" x Width 14" x Height 12", or 16-1/2" with the optional Flanging Attachment. Approximate weight 150 lbs. Needle bearings throughout. Motor, standard 1/2 HP 115 volt. AC Drive, single "V" belt. One piece machine cut, and hardened Pittsburgh lock rolls, gears, and shafts.

Capacity, 24 to 30 gauge mild or galvanized sheet metal. The Pittsburgh lock takes 7/8" to 1" material. Depth of pocket is 5/16". Flanging Attachment produces 1/4" right angle flange on straight pieces or on curved pieces to a radius as small as 1-3/4".

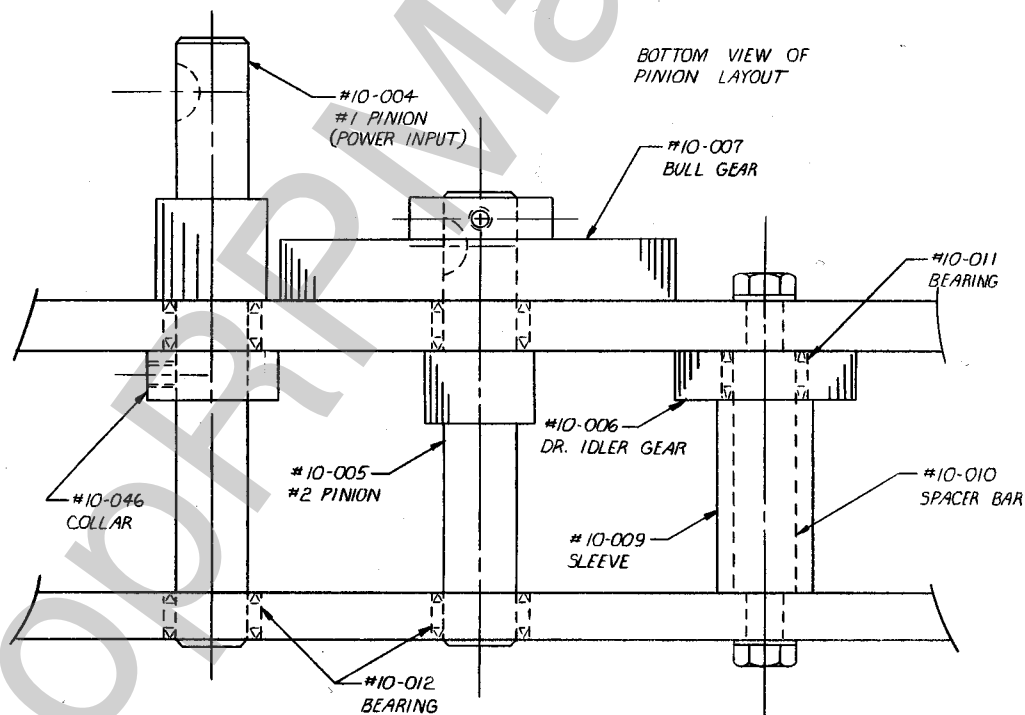

Machine on cover shown with optional Flanging Attachment and Floor Stand

Important: Disconnect Power Before Removing Covers for Any Reason

Parts List for Flagler Model 24 Junior

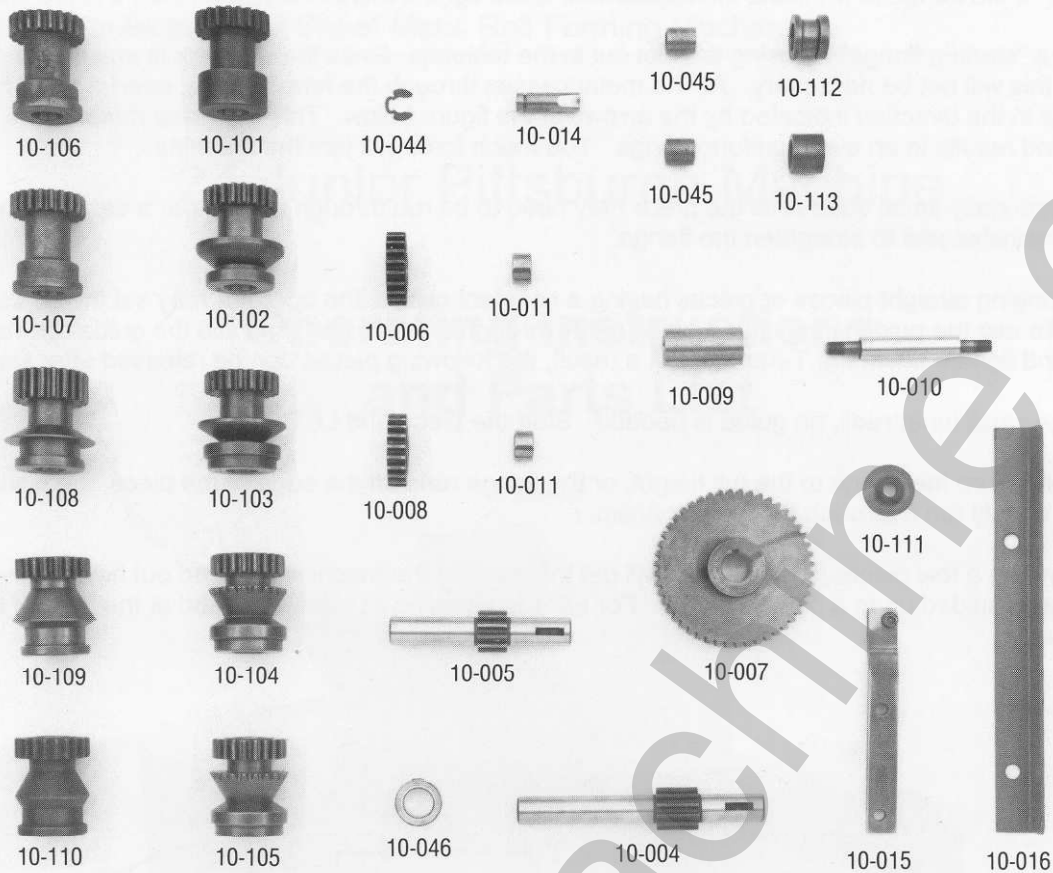

Part #	Description	Qty	Part #	Description	Qty
10-001	Back Plate	1	10-034	Pulley (Driven)	1
10-002	Lower Front Plate	1	10-035	"V" Belt	1
10-003	Upper Front Plate	1	10-036	Power Cord	1
10-004	#1 Pinion Gear*	1	10-038	Manual Switch	1
10-005	#2 Pinion Gear*	1	10-044	Snap Ring*	2
10-006	Driver Idler Gear*	1	10-045	Bushing*	2
10-007	Bull Gear*	1	10-046	Pinion Collar*	1
10-008	Idler Gear*	3	10-101	Bottom 5 Pittsburgh Roll*	1
10-009	Sleeve*	4	10-102	Bottom 4 Pittsburgh Roll*	1
10-010	Spacer Bar*	14	10-103	Bottom 3 Pittsburgh Roll*	1
10-011	Bearing 108*	24	10-104	Bottom 2 Pittsburgh Roll*	1
10-012	Bearing 128-OH	4	10-105	Bottom 1 Pittsburgh Roll*	1
10-014	Idler Roll Pin*	2	10-106	Top 5 Pittsburgh Roll*	1
10-015	Opening Roll Bracket (with pin)*	1	10-107	Top 4 Pittsburgh Roll*	1
10-016	Feed Gage*	1	10-108	Top 3 Pittsburgh Roll*	1
10-017	Angle Iron Head Support	2	10-109	Top 2 Pittsburgh Roll*	1
10-018	Pressure Bracket (Casting)	2	10-110	Top 1 Pittsburgh Roll*	1
10-019	Cover Assembly	1	10-111	Opening Roll*	1
10-022	Cabinet Assembly	1	10-112	Top Idler Roll*	1
10-032	½ HP Motor	1	10-113	Bottom Idler Roll*	1
10-033	Pulley (Motor)	1			

*Denotes illustrated part.

Contact your Flagler Distributor for price and availability of these and other Flagler Products.

Important: Disconnect Power Before Removing Covers for Any Reason

Operating Instructions

A feed gauge is located on the entrance end of the machine. Place the metal (24 Ga. Max) against this gauge and slide it into the forming head of the machine. The machine has been tested and adjusted at the factory, however to compensate for variations in material, it is necessary to make certain adjustments from time to time.

1. If the material pulls away from the feed gage, tighten the hold down stud at the entrance end until it corrects itself.
2. If the material slips or sticks upon exiting the forming head, tighten the hold down stud at the exit end slightly.

In feeding long sheets through the machine, be sure that they are flat against the table as well as against the feed gage, especially when the metal enters the roller dies.

COVER MUST BE IN PLACE WHEN IN OPERATION

CAUTION

Burrs and jagged edges should be flattened out so that they do not hit the opening roll, which might cause breakage. If the edge of the sheet to be formed is kept smooth, the blade-edged roll, which holds open the pocket in the Pittsburgh lock, will not chip or break.

LUBRICATION

Due to the low speed of this machine, the shafts do not require lubrication. However if galvanized metal is to be used, the roller dies must be periodically lubricated to remove any galvanized buildup. Specifically, the opening roll should be kept free of any type of buildup. This can be accomplished using Flagler Lubaroll. Also, the motor should be oiled periodically and not less than three times a year.

SPECIFICATIONS

Length 30" x Width 14" x Height 12", or 16-1/2" with the optional Flanging Attachment. Approximate weight 150 lbs. Needle bearings throughout. Motor, standard 1/2 HP 115 volt. AC Drive, single "V" belt. One piece machine cut, and hardened Pittsburgh lock rolls, gears, and shafts.

Capacity, 24 to 30 gauge mild or galvanized sheet metal. The Pittsburgh lock takes 7/8" to 1" material. Depth of pocket is 5/16". Flanging Attachment produces 1/4" right angle flange on straight pieces or on curved pieces to a radius as small as 1-3/4".

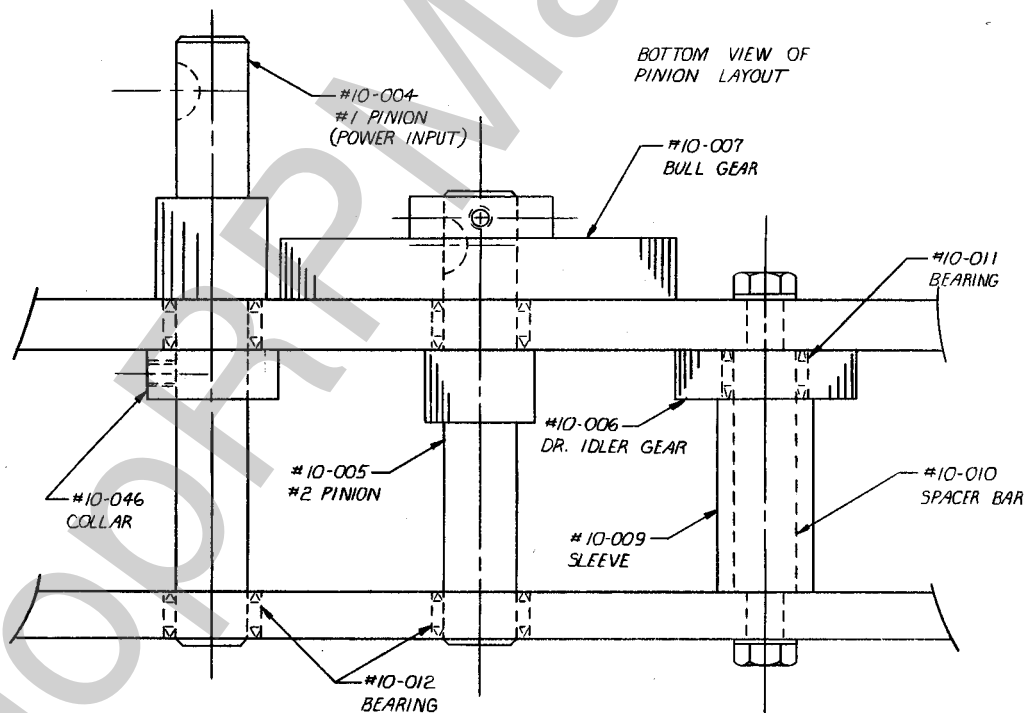

Machine on cover shown with optional Flanging Attachment and Floor Stand

Important: Disconnect Power Before Removing Covers for Any Reason