

# **ROPER WHITNEY/CONNECTICUT FLOOR MODEL MANUAL BENDING BRAKES**

**MODELS 816, 1018 AND 1016**

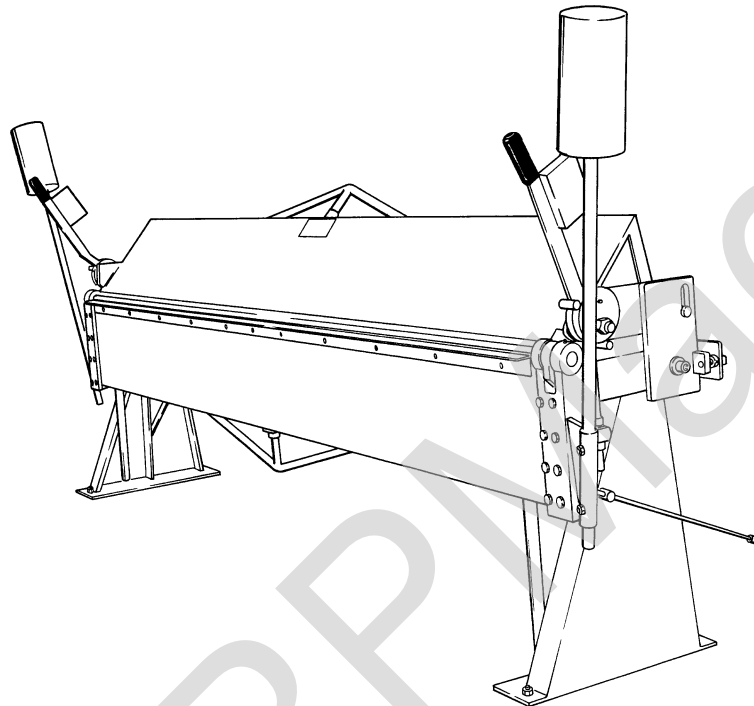

## **INSTALLATION, OPERATION, AND MAINTENANCE MANUAL**

**Version 2.1**



**ROPER WHITNEY**

2833 HUFFMAN BLVD  
ROCKFORD, ILLINOIS 61103  
815/962-3011  
815/962-2227 FAX

# ROPER WHITNEY/CONNECTICUT FLOOR MODEL MANUAL BENDING BRAKES

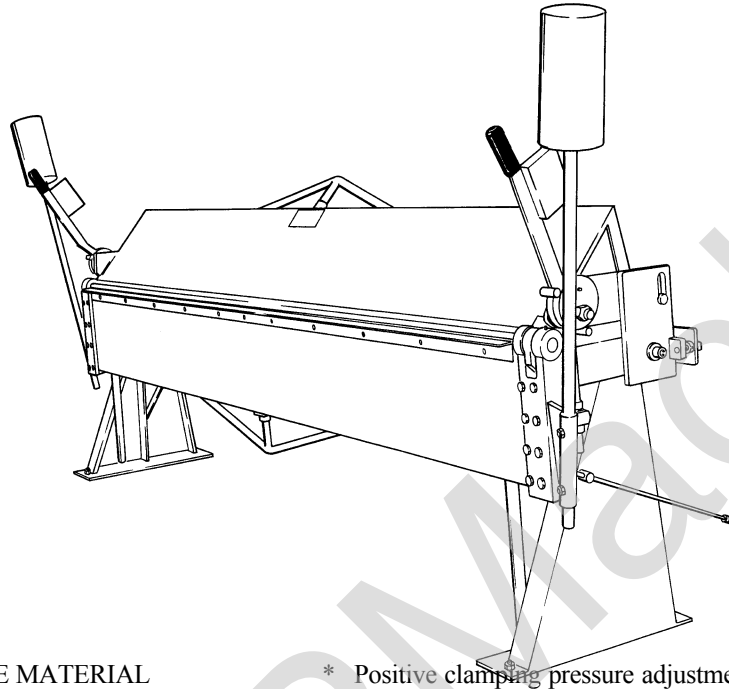

FOR 16-18 GAUGE MATERIAL

- \* All steel construction — no castings
- \* Heavy tie rods for minimum deflection
- \* Removeable bending bar and angle
- \* Adjustable apron hinges
- \* Positive rear material gauge adjustment
- \* Positive clamping pressure adjustment
- \* Apron stop rod for repeat bends
- \* Replaceable bushings and hinge pin
- \* Long handles for extra leverage
- \* Work support angle bar for full capacity 1-inch minimum flange
- \* Improved leg design for lighter weight

## INSTALLATION, OPERATION, AND MAINTENANCE MANUAL

Version 2.1



ROPER WHITNEY

2833 HUFFMAN BLVD  
ROCKFORD, ILLINOIS 61103  
815/962-3011  
815/962-2227 FAX

## ABOUT THIS MANUAL

---

### CONTENT

This manual contains information on the Roper Whitney Company line floor-mounted manual bending brakes for 16- to 18-gauge material.

The contents include a machine description, safety precautions, instructions for installation, adjustment, operation, maintenance, and repair; and a parts list providing a listing of repair parts.

### AUDIENCE

The manual is written with the experienced sheet metal operator in mind. The operator should be familiar with tooling, machine setup, materials, work methods, and setup and finished product inspection. Experienced operators not familiar with the equipment covered will be able to set up and run the machine from the manual. Novice operators can be trained from the manual, but additional instruction may be needed.

It is strongly recommended that anyone using the equipment covered read the manual thoroughly, and understand the material presented.

### INFORMATION USAGE

The setup and operating instructions are based on the intended application of the machine as defined by Roper Whitney. Use of the machine for other applications is not precluded, but use for purposes specifically excluded is not recommended, and may void warranty provisions.

Material in this manual is confidential, and Roper Whitney reserves all rights in this regard.

### ADDITIONAL ASSISTANCE

If you have questions concerning usage or operating techniques not covered by this manual, or if you encounter maintenance or repair problems, Roper Whitney field service and product support personnel can provide you with assistance. Before calling, please obtain the following information:

- \* machine type
- \* machine serial number
- \* description of application you wish to attempt
- \* description of problem you have encountered

Contact:

Roper Whitney  
2833 Huffman Boulevard  
Rockford, Illinois 61103  
Phone: 815/962-3011  
Fax: 815/962-2227

# TABLE OF CONTENTS

<b>About This Manual</b>	<b>ii</b>
<b>Warranty Provisions</b>	<b>iv</b>
<b>Section 1: Safety Precautions</b>	<b>1</b>
General Precautions .....	1
Safety Precautions During Operation .....	2
<b>Section 2: Machine Description</b>	<b>3</b>
<b>Section 3: Specifications</b>	<b>4</b>
<b>Section 4: Receiving and Installation</b>	<b>5</b>
Receiving .....	5
Unloading .....	5
Unpacking .....	5
Site Preparation .....	6
Setting the Brake .....	7
Leveling the Brake .....	7
Anchoring the Brake .....	7
Installing the Counterweights .....	8
<b>Section 5: Setup</b>	<b>9</b>
Setting Clamping Pressure .....	9
Adjusting for Material Thickness .....	10
Setting Up for Narrow or Offset Bends .....	11
Setting Up the Bend Angle Stop .....	12
Setting Up the Optional Rear Material Stops .....	12
<b>Section 6: Operation</b>	<b>13</b>
General Instructions .....	13
Clamping the Material .....	13
Bending the Material .....	14
Bending of Multiple Thicknesses .....	14
Hemming .....	15
<b>Section 7: Periodic Maintenance</b>	<b>16</b>
Lubricating Rotating Components .....	16
Lubricating Sliding Components .....	16
Lubricating Adjusting Nuts and Screws .....	16
Adjusting the Clamping Collars .....	17
<b>Section 8: Maintenance Adjustments</b>	<b>18</b>
Brake Crowning Adjustments .....	18
Preloading Adjustment .....	20
<b>Section 9: Repair Parts List</b>	<b>23</b>

## LIMITED WARRANTY

---

### COVERAGE

All new Roper Whitney tools and machines are warranted, to the original purchaser for use, to be free of defects in material and workmanship for a period of one year from purchaser's date of purchase. Roper Whitney, at its option, will repair, replace, or refund the purchase price of any tool or machine which fails within the warranty period, and is found upon examination by Roper Whitney, to be defective in material or workmanship, or both. This warranty does not cover failures attributable to improper use or maintenance, exceeding rated capacity, alteration, accident, or normal wear of moving parts. Accessories, controls, and components not manufactured by Roper Whitney Company are excluded from this warranty. For services on such parts, refer to the applicable manufacturers' warranties.

### EXCLUSIONS

There is no other express warranty to the extent permitted by law. Any and all implied warranties, including merchantability and fitness for a particular purpose are excluded; and implied warranties not excluded are limited in duration to one year from the date of purchase. Incidental and consequential damages are expressly excluded from the remedies available to purchaser, and the remedies provided in this warranty shall be exclusive to the extent permitted by law. (Note: Some states do not allow limitations on how long an implied warranty lasts, or the exclusion or limitation of incidental or consequential damages; so the foregoing limitations and exclusions may not apply to you. This warranty gives you specific legal rights, and you may also have other rights which vary from state to state.)

### WARRANTY CLAIMS

Purchaser must give written notice to Roper Whitney Company, at the address shown below, of any warranty claims, within thirty days after failure, and if so instructed, return to Roper Whitney Company the parts to be replaced or repaired, with all transportation charges prepaid by purchaser. Replacement parts will be invoiced to purchaser, with credit issued for parts covered by this warranty, and freight thereon. Removal and reinstallation of replacement parts shall be at the purchaser's expense.

### REGISTRATION

Return of the warranty registration card furnished with the product purchased is necessary to obtain warranty coverage thereon. The card must be fully completed, signed by the purchaser, and, if applicable, signed by the distributor. Return the registration card to:

Roper Whitney  
2833 Huffman Boulevard  
Rockford, Illinois 61103

# SECTION 1

## SAFETY PRECAUTIONS

### GENERAL PRECAUTIONS

Before using the Roper Whitney manual brake, carefully read and fully understand the safety precautions outlined in this section. **GENERAL PRECAUTIONS** pertain to the general workplace, and to the attitudes and work habits you bring to the job. **SAFETY PRECAUTIONS DURING OPERATION** pertain to work on the brake, and are repeated in other areas of the manual where they pertain.

Do not consider this section to be all-inclusive on the subject of safety. It is intended to be a general guide to safety practices as they pertain to the machines covered by this manual. No set of guidelines can substitute for a common-sense, informed, proficient, safety-conscious attitude on your part.

Notify management or supervision whenever you feel there is any hazard involving the equipment or the performance of your job.

Never permit untrained individuals to operate this equipment without close supervision. Be sure you know and understand the task at hand, and the hazards associated with it.

Observe and follow safety instructions for your work area. Pay special attention to posted warnings, and warning labels on the equipment. Do not place speed above safety.

Wear appropriate clothing. Loose or hanging clothing or jewelry, finger rings, etc. can be hazardous. Use the appropriate safety equipment, such as eye and hearing protection, and safety-toe shoes. If gloves are worn to protect from cuts, be sure they are snug-fitting and not likely to be snagged by moving equipment.

Keep the work area neat and orderly. Be sure it is well lit, that extra tools are put away, trash and refuse are in the proper containers, and dirt, chips or debris have been removed from the working areas of the machine. Be sure the floor area is clean and dry, and that extension cords and similar trip hazards have been removed.

Use the proper tools for the job. Inspect them before use to see that they are in good working condition. Replace broken or defective tools and equipment.

Use only approved cleaning materials: do not use explosive or flammable liquids to clean the machine. Discard used cleaning materials in the appropriate containers.

Do not use compressed air to clean debris, chips, dirt, or grit from the machine, or from your clothing. Remove chips and grit from the machine with a suitable brush; never with your hands.

**SAFETY  
PRECAUTIONS  
DURING  
OPERATION**

Do not attempt to operate the brake in excess of its rated capacity. Do not attempt to form wire, nails, rods or pipe on the machine.

Avoid any pinch points created by movement of the machine's components.

Exercise care around the bending apron counterweights. Stand clear of the ends of the brake during the bend cycle or whenever the bending apron is moved. Do not loosen the set screws securing the counterweight rods while the bending apron is in the vertical position.

**WARNING**

**SERIOUS INJURY MAY OCCUR**

The counterweight and rod can drop suddenly through the holder.

Always use the apron lift handles to apply the bending force. Under no circumstances use the counterweight rods for leverage. Failure to heed this warning can cause personal injury or damage to the counterweight rods. Always stand clear of the apron lift handle travel arc during the bend cycle to avoid being struck by the handles.

**WARNING**

**SERIOUS INJURY MAY OCCUR**

Avoid pinch points created by the clamping and bending components.

Always stand clear of clamping handles. If the brake has not been properly adjusted for material thickness; clamping action on one end of the brake may cause the opposite clamping handle to snap forward due to the twisting stress created on the upper beam. (this can also indicate that the clamping collars need adjustment. Refer to **Section VII, Periodic Maintenance.**) When opening the upper beam make sure the handles are moved to the horizontal position to avoid accidental forward movement of the handles caused by the weight of the upper beam.

If you observe unusual noises or vibrations during machine operation, check the machine condition immediately. Do not attempt to operate the equipment further until the causes of unusual behavior have been found and corrected.

## SECTION 2

# MACHINE DESCRIPTION

Roper Whitney floor mounted manual bending brakes are precision machines for use in bending mild steel and other sheet metals, including aluminum, brass, bronze, copper, duralumin; lead, monel metal, silver, carbon and stainless steel within rated capacity.

The brakes are rated to form a 1-inch minimum wide flange over entire length of brake on a single thickness of material of the rated gauge capacity with work angle support installed. Bending capacities are reduced by four (4) gauges when the apron work support is removed.

The machines are essentially identical in construction, varying only in length or capacity. Major components are shown in Figure 1.

Fabricated of sturdy steel plate with appropriate gussets, braces and trusses; three basic longitudinal members (upper-beam, lower-beam and bending leaf/apron) control the clamping pressure and stress incurred in overcoming the yield strength of the material being formed. Provisions for adjusting clamping force and tensioning of the longitudinal members are incorporated in the design of the bending brakes.

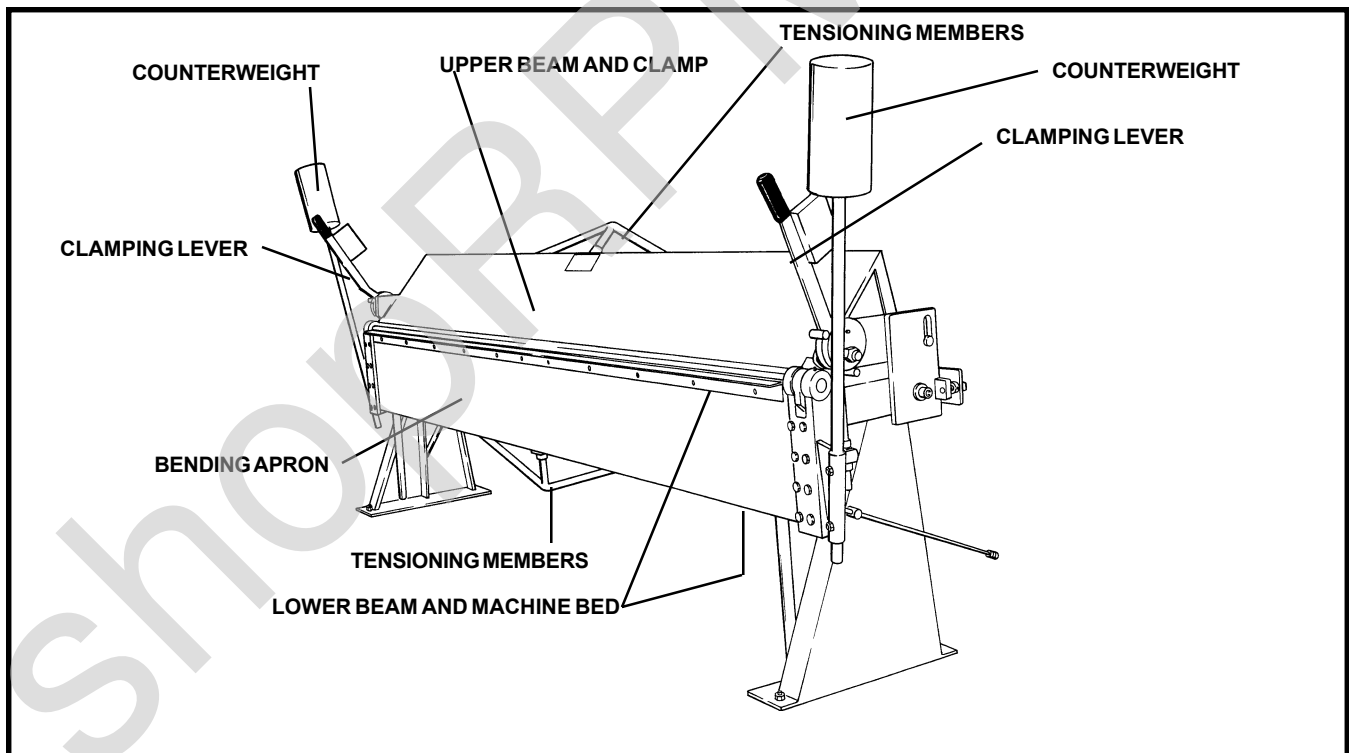

**Figure 1. Major Components of the Floor Mounted Manual Bending Brakes.**



## SECTION 3 SPECIFICATIONS

Feature	Model 816	Model 1016	Model 1018
Bed Length	97 in.	121 in.	121 in.
Capacity on mild steel, 1-in. flange With bending bar and angle in place With bending angle removed With bending bar and angle removed	16 Ga. 20 Ga. 24 Ga.	16 Ga. 20 Ga. 24 Ga.	18 Ga. 22 Ga. 26 Ga.
Minimum Reverse Bend (bending bar and angle removed)	5/16 in.	5/16 in.	5/16 in.
Maximum lift of beam	1-5/8 in.	2-1/4 in.	1-5/8 in.
Front to Rear Adjustment of Beam	1-1/8 in.	1-3/8 in.	1-1/8 in.
Approximate Shipping Weight	1640 lbs.	2660 lbs.	2200 lbs.
Closed Hems	24 Ga.	22 Ga.	24 Ga.
Packing	heavy wood skids and blocking with a plastic cover		

## SECTION 4

# RECEIVING AND INSTALLATION

### RECEIVING

When you receive your bending brake, check immediately for obvious damage, which may have occurred during transit, to the skidding material or to the brake itself. Also check to see that all material listed on the bill of lading is present.

Since Roper Whitney equipment is normally sold F.O.B., factory in Rockford, IL, our responsibility for transit damage ceases when the transportation company signs the bill of lading indicating it has received the items listed in good condition.

Report discovered damage or shortages to the carrier. Make a notation on the delivery waybill, and have the delivering driver sign it, acknowledging the damage or shortage.

Submit claims for repair or replacement to the carrier; include any extra shipping charges. Notify Roper Whitney Company promptly of any damage or shortages.

If you discover concealed damages or shortages after the carrier has departed, you may still file a claim for concealed damage. This should be done as quickly as possible. Again, notify Roper Whitney Company promptly of such damages or shortages.

### UNLOADING

The brake is shipped on a skid of 3" x 6" wood timbers. It is secured to this skid with four (4) carriage bolts, which should remain secured while the machine is unloaded and moved about. The skid and brake may be moved using a suitable fork lift.

#### **WARNING**

#### **WHEN IN MOTION, THE SKIDDED BRAKE MAY BE TOP HEAVY**

When lifting or moving the skidded brake with a forklift, secure the brake laterally to the forklift.

### UNPACKING

The two counterweight arms (rods) and their counterweights are mounted separately on the wooden skid for shipment. Remove these from the skit and set to one side.

#### **WARNING**

#### **THE COUNTERWEIGHT ARMS AND COUNTERWEIGHTS ARE HEAVY**

Use care when removing them from the skid to avoid injury.

The clamping handles at each end of the brake are wrapped and wired in the down position to prevent damage and to prevent the handles from being used to move the brake. Remove the wires and wrapping.

Wooden blocks are positioned between the upper and lower beam jaws to prevent damage during shipment. Lift the clamping handles and remove the blocks.

The bending leaf (apron), is wired to the center truss stud of the lower beam to prevent movement during transit. Remove the wire.

Remove the four (4) carriage bolts, nuts, and washers securing the brake to the skidding. **DO NOT REMOVE THE BRAKE FROM THE SKID AT THIS TIME.**

**WARNING AND CAUTION**

**SERIOUS INJURY CAN RESULT OR THE BENDING BRAKE CAN BE DAMAGED**

Do not operate the brake on the skid. The brake must be attached to the floor. The machine is topheavy and can tip if not securely anchored. The skid does not provide a suitable anchoring platform.

**SITE PREPARATION**

The brake must be placed on a firm floor which does not sag and which does not have any "spring" to it. The floor must be generally level, with no twisting or unevenness in the surface. The floor must also be capable of accepting 1/2-inch lag screws or bolts for the purpose of securing the brake.

There must be adequate area around the brake for free movement of the operator and the handling of large sheets of metal. Allow 4 to 6 feet behind the brake, 6 to 8 feet in front of the brake, and 3 feet on either end of the brake.

To move the brake off the skid, and to its mounting position, use an overhead crane or a fork lift with the forks above the brake. If a fork lift is used, secure a lifting hook on the lift forks. Pass a sling under brake and secure each end on the lifting hook as shown in Figure 2.

**CAUTION**

**THE BENDING BRAKE CAN BE DAMAGED**

Do not move the brake using lift truck forks directly under any machine members.

## SETTING THE BRAKE

Using the overhead crane, lift the brake from the skid and place it in its desired location. Be sure the brake is properly balanced.

### **WARNING**

**THE BRAKE TENDS TO BE TOPHEAVY AND CAN TWIST IN THE SLING**

Use care when moving the brake from the skid to avoid injury.

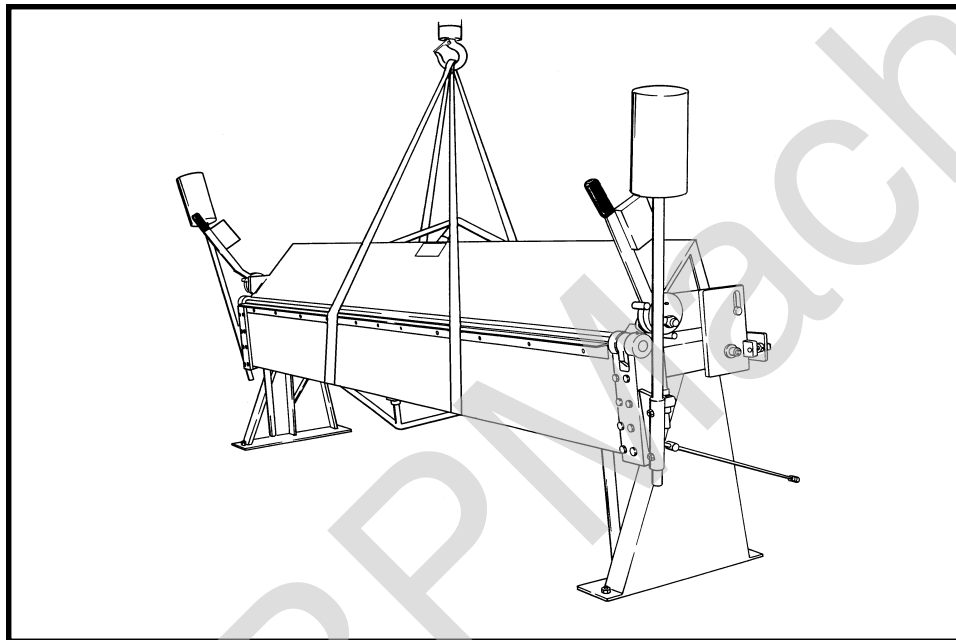

**Figure 2. The proper lifting method for moving the brake.**

## LEVELING THE BRAKE

Raise the upper beam to its maximum height using the eccentric lifting levers. Place an accurate spirit-level on the bed at each end of the bed bar.

Shim under the legs of the brake until the bed bar shows the machine is level front-to-rear. This will remove any twist from the bed. Side-to-side leveling is not necessary to proper operation of the brake.

## ANCHORING THE BRAKE

Anchor the leveled brake to the floor using 1/2-inch lag screws or bolts through the leg mounting holes. Tighten securely, making sure pressure is exerted on the leveling shims.

**INSTALLING THE  
COUNTER-  
WEIGHTS**

Have an assistant raise the bending apron to the horizontal position, and hold it in that position while the counterweights are installed.

Install a counterweight in the mounting hole in each end of the bending apron. Adjust the counterweights so that they balance the bending apron in the horizontal position.

Tighten two set screws securely on each counterweight shaft.

**WARNING**

**THE COUNTERWEIGHTS ARE HEAVY**

Use care when installing the counterweights to avoid injury. Be sure the set screws are tightened enough so the counterweights will not drop when the bending apron is returned to the vertical position.

## SECTION 5

### SETUP

#### SETTING CLAMPING PRESSURE

The machine has been adjusted and pretensioned at the factory. Set-up adjustments are for clamping pressure, material thickness, setting up for narrow or offset bends, setting bend angle control, and setting up of the optional rear material stops.

Excessive clamping pressure is not required or desirable. It has a tendency to counteract the normal preloading adjustments and may interfere with obtaining straight and uniform bends. Use only enough clamping pressure to keep the material from slipping.

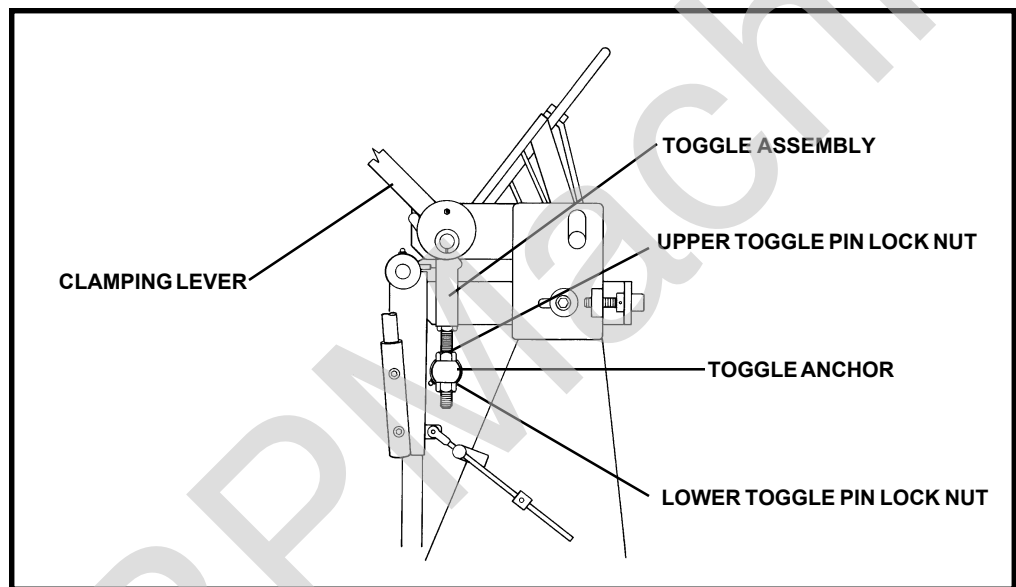

**Figure 3. Clamping Pressure Adjustments.**

Be sure the gauge thickness of the material to be formed to is within the rated capacity of the machine. Then adjust clamping pressure as follows:

1. At each end of the brake, loosen both toggle pin lock nuts slightly before beginning adjustment (see Figure 3).
2. Place small sample pieces of the material to be formed between the upper beam radius bar and the bed at each end of the machine. Clamp in position.
3. At each end of the machine, tighten the lower toggle pin lock nut against the toggle anchor just enough to hold material firmly when the clamping lever is against the forward stop (see Figure 3).

## SETTING CLAMPING PRESSURE

4. At each end of the machine, tighten upper toggle pin lock nut against the toggle anchor (see Figure 3).
5. At each end of the machine, pull the clamping lever forward against the stop. Each end should require equal effort. Adjust one end, if necessary, according to the general procedure above.

## ADJUSTING FOR MATERIAL THICKNESS

Under normal circumstances, clearance between the apron edge and the upper beam radius bar should be approximately (2) times the material thickness for 16 ga. mild steel. For lighter gauge material, less clearance is required. One and a half (1-1/2) times material thickness is usually sufficient. Soft material, such as aluminum, may be formed with a clearance equal to the material thickness.

### **CAUTION**

#### **THE BENDING BRAKE CAN BE DAMAGED**

Clearance must never be less than the material thickness.

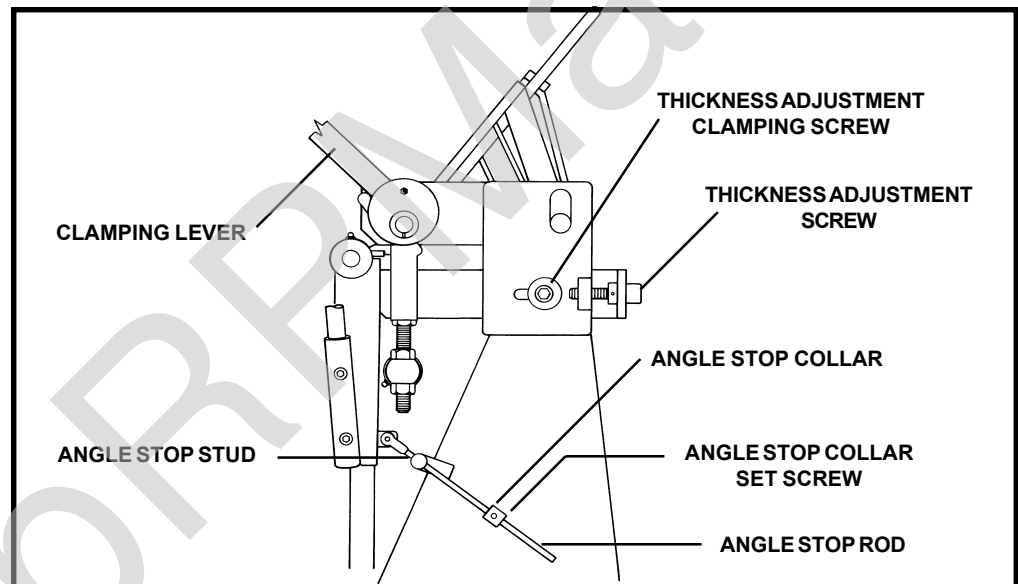

**Figure 4. Material Thickness and Angle Adjustments.**

Make the adjustment as follows:

1. With the upper beam lowered to the normal operating position, but not clamped tightly against the bed, loosen the thickness adjustment clamping screws located on both ends of the brake (see Figure 4).
2. Raise the apron to the 90-degree position.

## ADJUSTING FOR MATERIAL THICKNESS

3. Move the upper beam forward or back until proper clearance is achieved by turning the thickness adjusting screw located at rear of the leg bracket on each end of the machine (see Figure 4). Final adjustment must always be toward the front of the brake to remove backlash from the adjusting screws.
4. Retighten the clamping screw on each end of the machine (see Figure 4).

## SETTING UP FOR NARROW OR OFFSET BENDS

It is sometimes necessary to remove the bending reinforcing angle to make narrow or offset bends. In extreme conditions, it may also be necessary to remove the bending bar. The bending bar is made of tough, wear resistant material to protect the edge of the apron and should be removed only when absolutely necessary to make tight reverse bends.

Removing the bending reinforcing angle reduces capacity by four (4) gauges. The rated 16 ga. capacity is reduced to 20 ga. capacity. Removing both the bending reinforcing angle and the bending bar reduces the 16 ga. capacity to 24 gauge capacity.

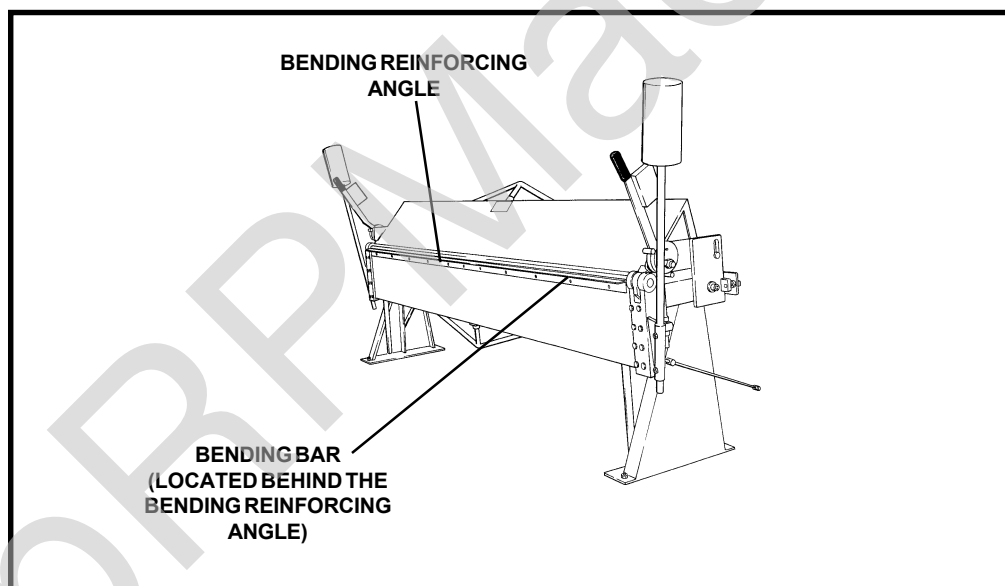

**Figure 5. Removal of the Bending Reinforcing Angle and the Bending Bar.**

Remove the bending reinforcing angle and the bending bar as follows:

1. Support the bending reinforcing angle and remove retaining screws. Withdraw the angle from the machine (see Figure 5).
2. Support the bending bar and remove retaining screws. Withdraw the bar from the machine (see Figure 5).
3. After the bending operation is complete, be sure to replace the removed components, attaching them with the retaining screws. Tighten the screws securely.



## SETTING UP THE BEND ANGLE STOP

The bend angle stop can be adjusted for multiple or precision bends. Adjust the angle stop as follows:

1. Loosen the angle stop collar set screw and move the angle stop collar out toward the end of the angle stop rod. (See Figure 4.)
2. Have an assistant move the apron to the desired position and hold it while you adjust the collar. Be sure to take spring-back into account when setting the angle.
3. Move the angle stop collar against the angle stop stud and tighten the angle stop collar set screw to retain it in that position.

## SETTING UP THE OPTIONAL REAR MATERIAL STOPS

For repeat operations involving deeper bends, it may be useful to use the optional rear material stops.

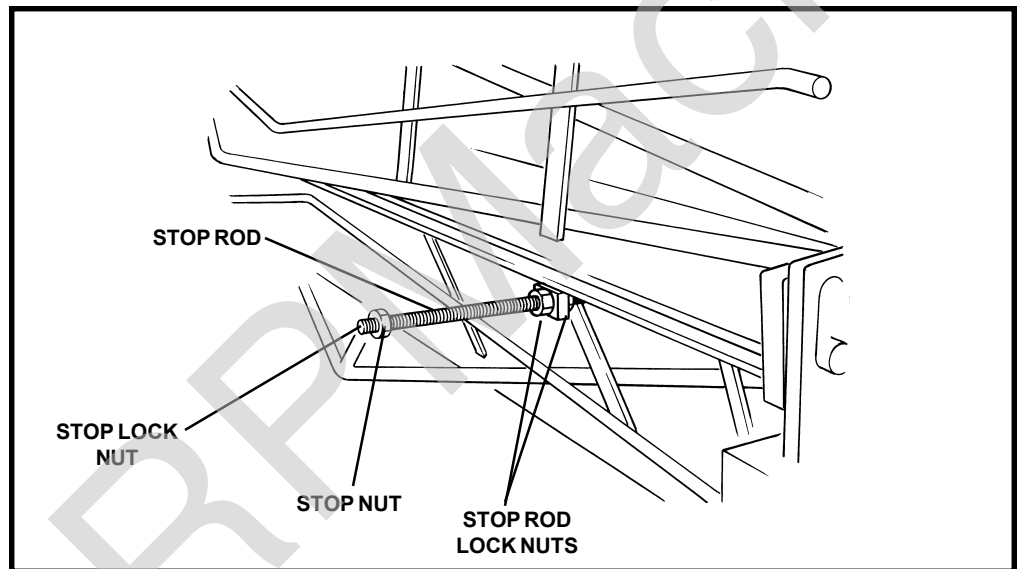

**Figure 6. Installing and Adjusting the Optional Rear Material Stops.**

Install and adjust the rear material stops as follows:

1. At each end of the machine, insert a threaded stop rod. Secure the stop rod using the stop rod lock nuts (see Figure 6).
2. Adjust a stop nut on each stop rod to the desired position. Be sure that both stop nuts are the same distance from the front of the machine. (Angular bends not perpendicular to the material edges can be made by offsetting one stop nut from the other. This will reduce the overall width which can be bent.) (See Figure 6.)
3. Lock each stop nut in place using a stop lock nut (see Figure 6).

## SECTION 6 OPERATION

### GENERAL INSTRUCTIONS

Operation of the brake is entirely manual, and the operator has full control of the operation at all times.

Do not attempt to operate the brake in excess of its rated capacity. Do not attempt to form wire, nails, rods or pipe on the machine.

If you are bending large sheets of material which are difficult to handle, you may wish to use an assistant to help in loading, clamping, and bending.

If you observe unusual noises or vibrations during machine operation, check the machine condition immediately. Do not attempt to operate the equipment further until the causes of unusual behavior have been found and corrected.

### **WARNING**

#### **PINCH POINTS CAN CAUSE SERIOUS INJURY**

Avoid any pinch points created by movement of the machine's components.

### CLAMPING THE MATERIAL

Insert the material to be bent under the upper beam clamping mechanism, lining up both sides so they are even with the upper beam. Position short pieces of material in the center of the brake to equalize strain during bending.

Clamp the material by lowering the upper beam with the clamping levers.

If the brake has not been properly adjusted for material thickness; clamping action on one end of the brake may cause the opposite clamping handle to snap forward due to the twisting stress created on the upper beam.

When opening the upper beam make sure the handles are moved to the horizontal position to avoid accidental forward movement of the handles caused by the weight of the upper beam.

### **WARNING**

#### **THE UPPER BEAM CLAMPING MECHANISM CAN CAUSE SERIOUS INJURY**

Always stand clear of clamping handles. Do not place fingers near or under the upper beam.

## **BENDING THE MATERIAL**

Bend the material to the desired bend angle using the apron lift handles to apply the bending force. Under no circumstances use the counterweight rods for leverage.

If the material being bent is long and protrudes from the machine, lift it during the bending operation to avoid creases or crimps caused by material weight.

### **WARNING**

#### **THE COUNTERWEIGHTS AND CLAMPING HANDLES CAN CAUSE INJURY**

Always stand clear of the ends of the brake during the bend cycle.  
Always stand clear of the apron lift handle travel arc during the bend cycle.

### **CAUTION**

#### **THE COUNTERWEIGHT RODS CAN BE DAMAGED**

Using the counterweight rods to apply bending force can damage them.

## **BENDING OF MULTIPLE THICKNESSES**

To avoid adjusting for every piece on a run of parts, do all the single-thickness bending operations first, then adjust and do the multiple thickness bending.

Never bend against hems or seams until an adjustment has been made to compensate for the clamping of multiple thicknesses of material. Never bend against hems or seams until the upper beam is set back for clearance of the multiple thicknesses of material. See **SETUP, SECTION 5**, for adjustment instructions.

### **CAUTION**

#### **MACHINE COMPONENTS CAN BE DAMAGED**

Failure to compensate for multiple thicknesses of material may result in breakage of the clamping mechanism.

Failure to set the upper beam back for extra clearance may result in indentations on the upper beam jaw.

## HEMMING

Hemming is the most difficult operation to control accurately on a hand brake.

Hemming creates pressure loads on the machine different than those created by regular bending, and optimum results will not be obtained using the same machine preloading for both hemming and bending.

In factory tests, closing 24 Ga. material all the way along was done easily with no change in the preloading settings used for bending. 22 Ga. material was open about 1/32 inch in the middle and hems in 20 Ga. had an opening in the middle of just under 1/16 inch under like conditions.

If you must have tight hems in material heavier than 24 Ga., do all of the bending first, adjust the machine for hemming, and close the hems in a second operation.

### HEMMING... ...THE TRADITIONAL METHOD

Hemming is traditionally done by making a maximum bend of about 135 degrees and flattening it between beam and bed by lowering the clamping levers.

This approach may require additional preloading in order to close the hem tightly at the center. Increase the preload by tightening the upper beam tensioning adjusting nut (see Figure 9).

It also requires reducing clamping pressure to allow for multiple thicknesses of material. Reduce clamping pressure by slackening the lower toggle pin adjusting nut and tightening the upper toggle pin adjusting nut (See Figure 10).

### HEMMING... ...ANOTHER WAY

Remove the workpiece from the machine after bending. Close the machine by clamping the beam down on the bed with the clamping levers. Place the workpiece on the front surface of the upper beam. Swing the apron up and close the hem by squeezing the workpiece between the machined surface of the apron and the upper front surface of the radius bar.

This may feel awkward at first, especially if you are accustomed to hemming in the traditional manner, but it will get easier with practice and the end result is far superior to the traditional way.

It may be necessary to move the upper beam 1/8" to 3/16" to the rear to allow clearances for the hem between apron and front of beam. See **SETUP, SECTION 5**, for adjustment instructions.

## SECTION 7 PERIODIC MAINTENANCE

### LUBRICATING ....ROTATING COMPONENTS

Grease fittings are provided for rotating components where wear may occur. Use a medium weight bearing grease, such as SAE No. 30, and grease weekly when the brake is being used. The rotating components are: the clamping lever assembly, the apron hinge assembly (2 fittings), and the toggle pin bushing. One set of these components is found on each end of the machine. Location of these fittings is shown in Figure 7.

### ....SLIDING COMPONENTS

Grease sliding components weekly as well, using general purpose grease, or equivalent. These components include the clamping pin bushings and the slots in which they ride (see Figure 7).

### ....ADJUSTING NUTS AND SCREWS

The upper and lower beam tensioning screws (see Figure 8) are under heavy load and must not be allowed to run dry. Keep them lubricated with an anti-sieze compound.

If the machine is frequently readjusted, the lower apron tensioning lock nut (see Figure U), and upper beam tensioning lock nut, and the lower beam tensioning locknuts (see Figure 8), they should be kept lubricated with an anti-sieze compound.

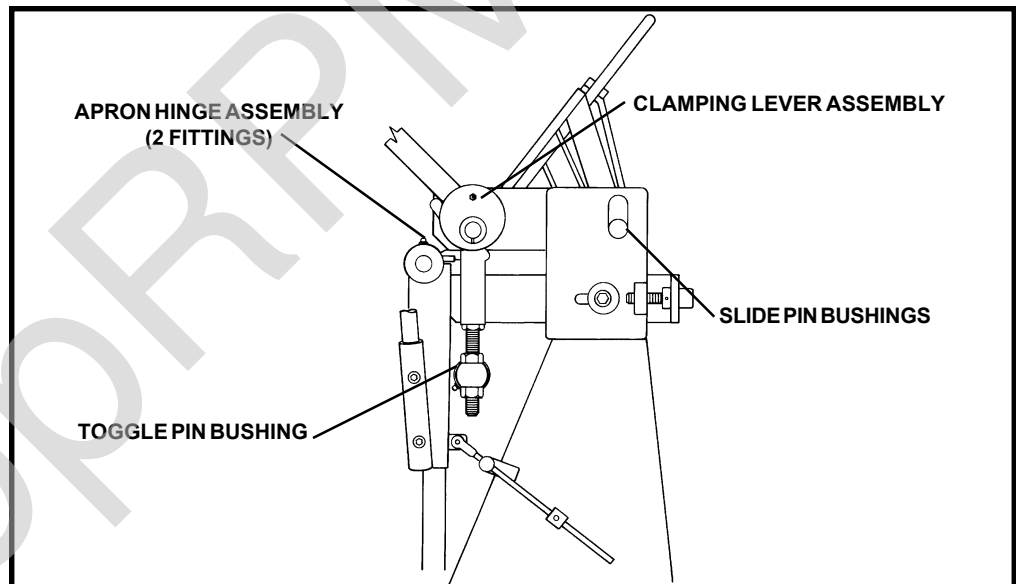
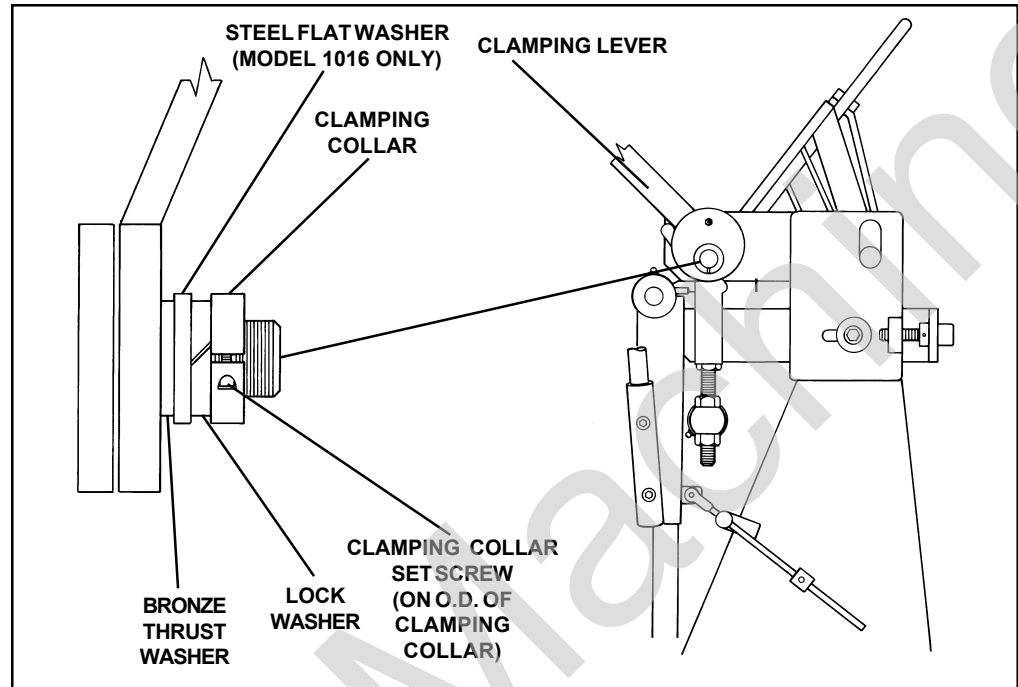

Figure 7. Grease Lubrication Points on the Brake

## ADJUSTING THE CLAMPING COLLARS

The retaining system used to hold the clamping levers in the open position require periodic adjustment. Adjust the collars using the following procedure:



**Figure 8. Adjusting the Clamping Lever Collars**

1. Slightly loosen the set screws retaining the clamping collars on each end of the machine. Set screws should be loose enough to permit adjustment of the clamping collars, but not so loose as to permit loss of position on the clamping collars when the clamping levers are moved.
2. Tighten the clamping collars by turning them clockwise, until you are unable to move the clamping levers to clamp material.
3. Back off the clamping collars by turning them counterclockwise until you can move the clamping levers to clamp material. The collars are properly adjusted when one lever can be unclamped, and the lever at the opposite end of the machine remains clamped. It may require several adjustments at each end of the machine to achieve the proper tension. During these adjustments, be sure the set screws remain tight enough to prevent loss of position by the clamping collars when the clamping levers are moved.
4. When the collars are properly adjusted, tighten the set screws securely to retain the clamping collars in place.

## SECTION 8

# MAINTENANCE ADJUSTMENTS

### BRAKE CROWNING ADJUSTMENTS

When the machine does not bend properly, it is sometimes necessary to readjust the crown on the beams. Use the following procedure:

1. Relieve all tension on the upper beam tensioning nuts and on the upper beam tensioning screw (see Figure 9).
2. Lower the upper beam onto the bed. Loosen lower toggle pin adjusting nut until there is 1/4-in. of space between bottom of the toggle anchor and the lower toggle pin adjusting nut (see Figure 10).
3. Adjust the upper beam and lower beam tensioning screws finger tight; and then tighten each with a wrench approximately one full turn (five flats) (see Figure 9).
4. Adjust the upper beam tensioning nuts finger tight, and then tighten each with a wrench approximately one full turn (five flats) (see Figure 9).
5. When looking from the rear of the brake, the upper beam and the bed should be in contact at the center and showing a crack of light at each end (see Figure 11). If less light shows at one end, loosen the rear floor bolt at that end and shim under the leg until the light shows evenly at both ends.
6. Tighten the lower toggle pin adjusting nut against the bottom of the toggle anchor (see Figure 11).

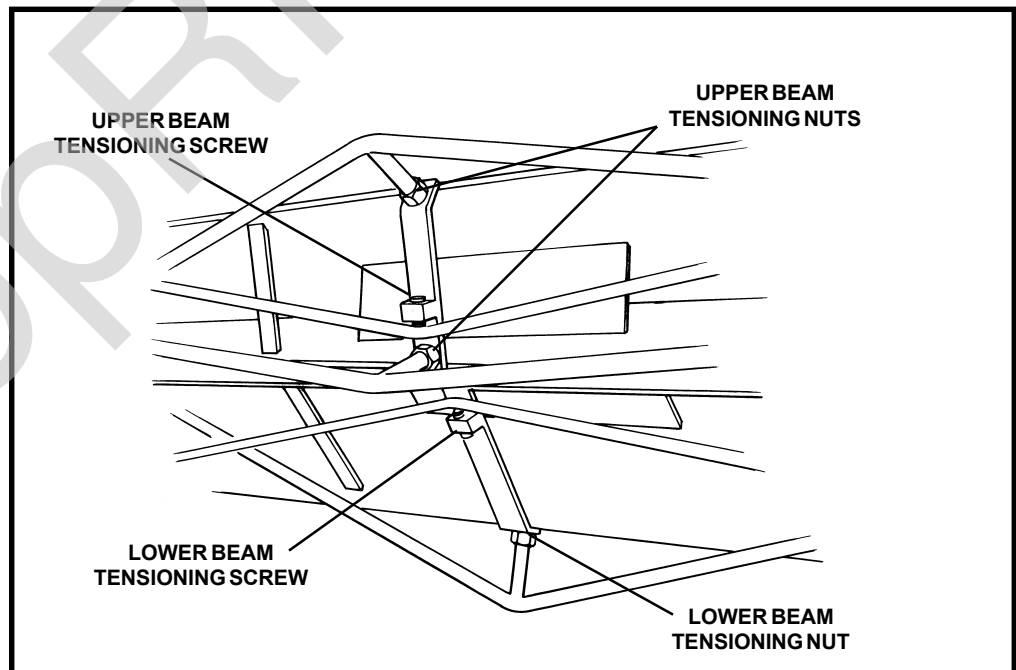
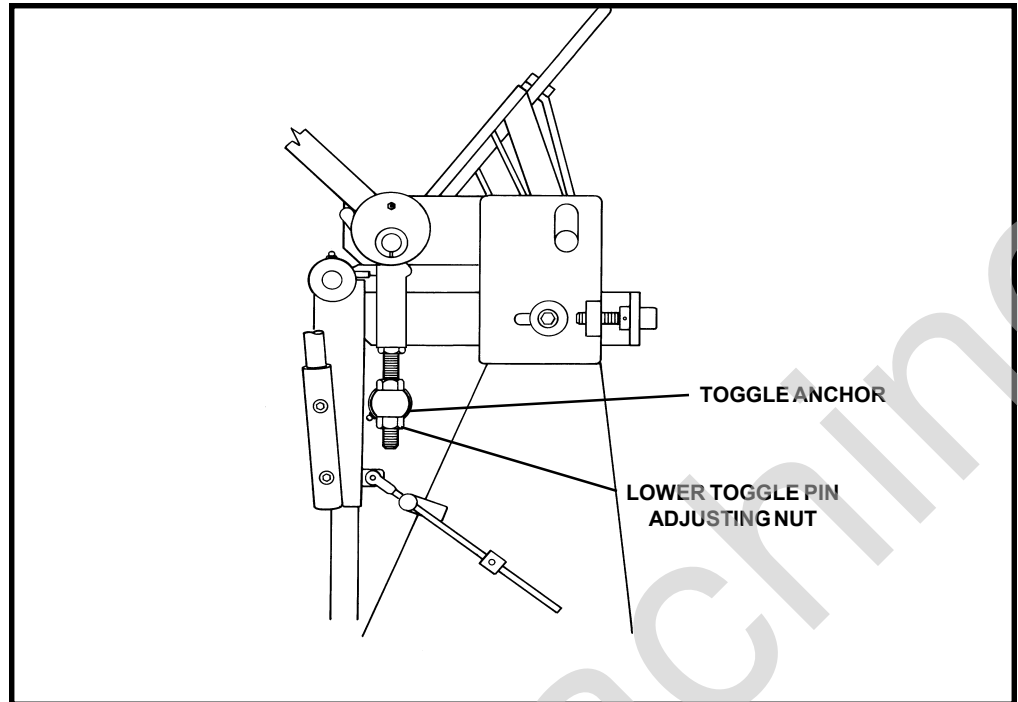
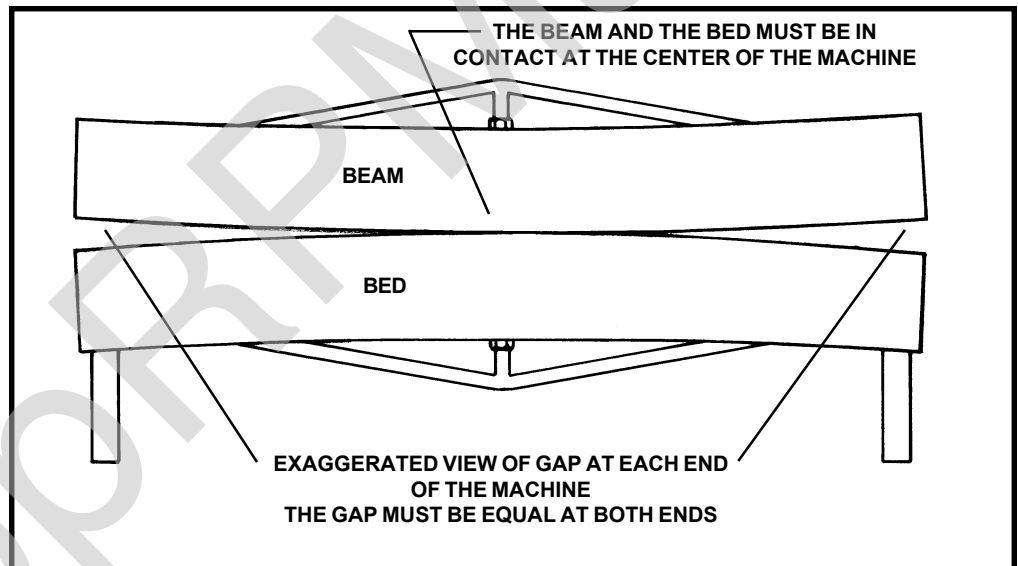

Figure 9. Upper Beam and Bed Tensioning Components.

## BRAKE CROWNING ADJUSTMENTS



**Figure 10. Upper Beam Clamp Adjusting Components.**



**Figure 11. Proper Clearance Between the Upper Beam Clamp and the Bed.**



## PRELOADING ADJUSTMENT

Once the brake crown has been set, the brake must be adjusted to produce straight bending and a uniform radius. Follow the procedure below:

1. Loosen the apron tensioning nuts on the apron, (see Figure 12) and the upper and lower beam tensioning nuts (see Figure 9).

**On the Model 1016 brake** also loosen the apron stiffener adjusting nut located behind the lower apron tensioning adjusting nut (see Figure 12).

2. Loosen the upper and lower beam tensioning screws (see Figure 9).
3. Raise the upper beam to its maximum open height
4. Check the top edge of apron in relation to the top surface of the bed. The top edge of apron must be 1/64-in. below the top surface of the bed at each end. If not, loosen the hinge bolts and adjust the apron up or down using the apron jack screws (see Figure 13). After the apron edge is adjusted to the proper position, be sure to retighten the hinge bolts.
5. Tighten the apron stiffener adjusting nut until the apron edge is 1/32-in. above the bed edge at the center (see Figure 12). The apron edge should remain 1/64-in. below the bed edge at both ends.
6. Adjust the upper and lower beam tensioning screws finger tight; and then tighten each with a wrench approximately one full turn (five flats) (see Figure 8).

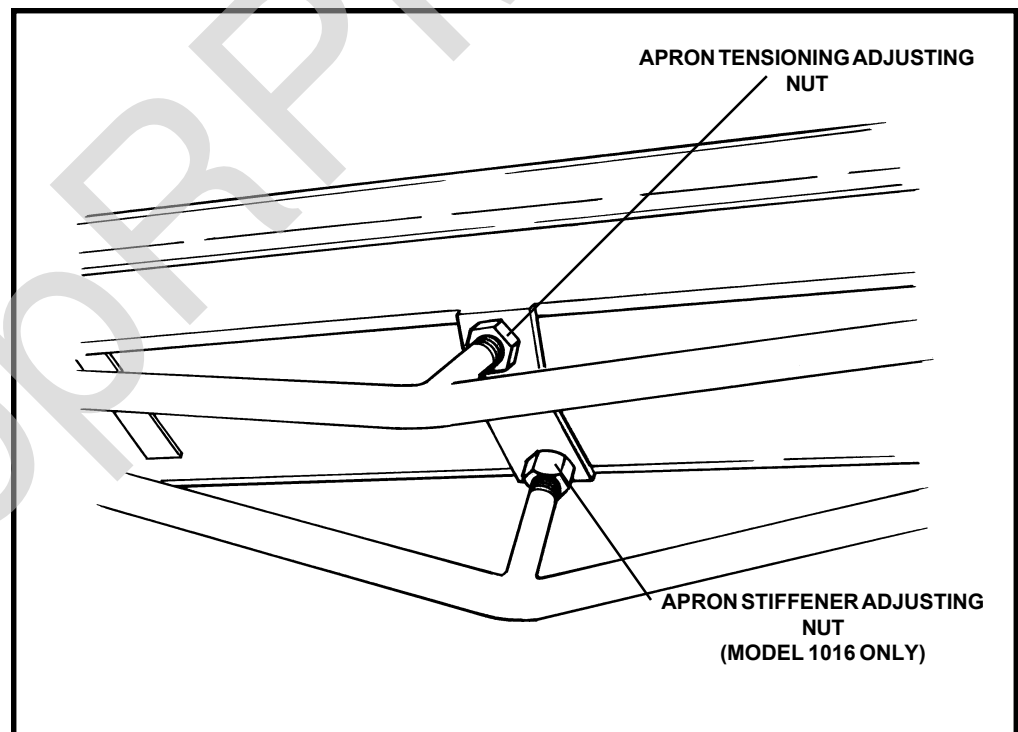

Figure 12. Preloading Adjusting Components.

## PRELOADING ADJUSTMENT

7. Tighten lower beam tensioning nut until the edge of the bed is  $1/64$ " above the top edge of the apron at the center (see Figure 9). The edges of the bed and apron will then be parallel from end to end, with the edge of the bed  $1/64$ " higher than the apron edge.

**On the Model 1016 brake** tighten the apron stiffener strap bolt located behind the lower apron tensioning nut until the horizontal gap between the bed and apron is slightly greater in the center than at the ends (see Figure 12). It may then be necessary to back off the lower apron tensioning nut slightly to maintain the bed  $1/64$ -in. higher than the edge of the apron.

8. Tighten upper and lower beam tensioning nuts finger tight; and then, using a wrench, tighten each from  $1/4$  to  $1/2$  turn.

The bending brake is now properly adjusted for its rated gauge capacity in mild steel.

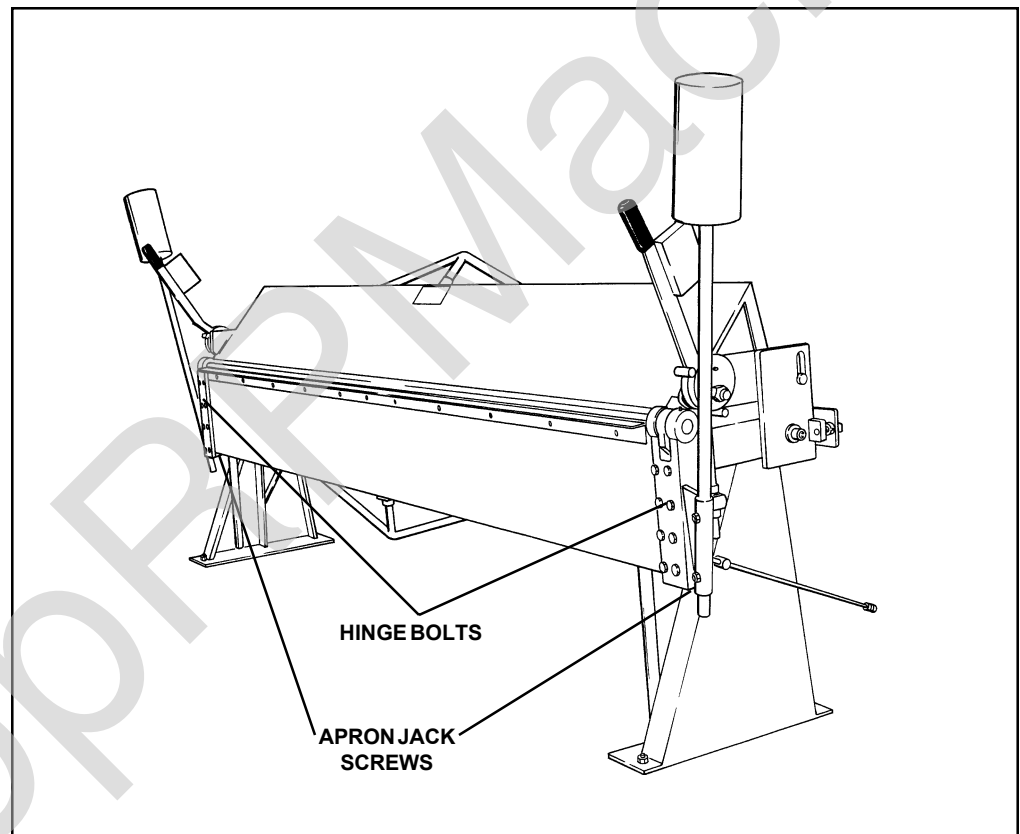

**Figure 13. Apron Adjusting Components.**

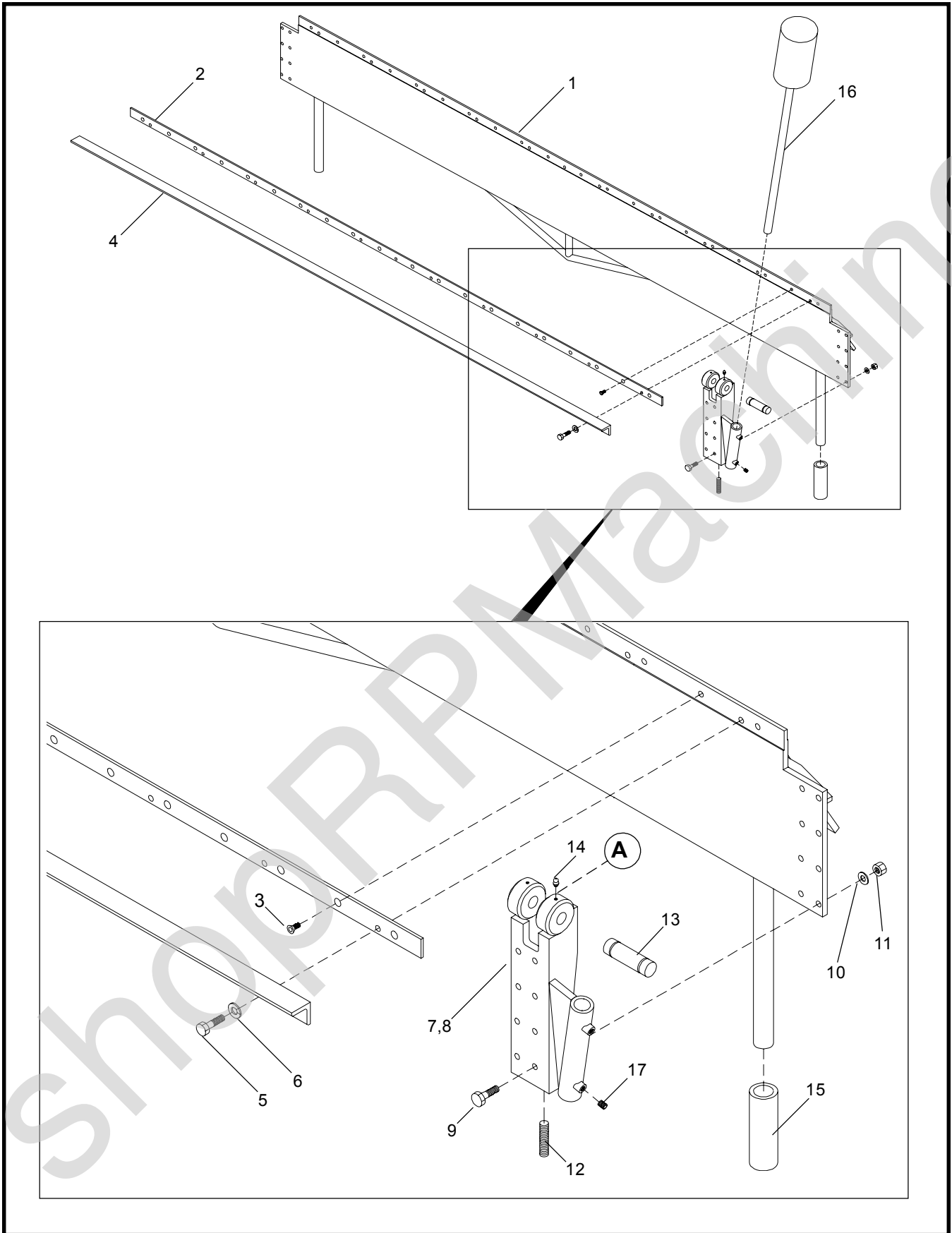

Figure 14. Exploded View of Replacement Parts

## SECTION 9 REPAIR PARTS

The table below identifies parts which may be replaced on the Roper Whitney manual bending brake. Parts may be ordered directly from your Roper Whitney distributor. If you have no distributor in your area, you may order the parts directly from the company. Common hardware items such as screws and nuts may be purchased locally, so long as the items purchased are of equivalent quality to those originally supplied with the machine.

The **Ref. No.** column is keyed to the exploded view on the facing page. The **Part Number** columns provide part numbers for replacement parts for each model brake covered by this manual. The **Part Name** column provides a short descriptive name for each replacement part. The **Qty.** column identifies the quantity required for replacement.

Ref. No.	Part Number			Part Name	Qty.
	Model 1018	Model 1016	Model 816		
1	257020009	257020003	257020006	Apron Assembly	1
2	757030029	757030029	757030013	Bending Bar	1
3		613012131		Screw, Flat Head, 5/16-18 by 3/4	21
3	613012131		613012131	Screw, Flat Head, 5/16-18 by 3/4	17
4	757180028	757180028	757180012	Bending Angle	1
5	601012271	601012271		Cap Screw, Hex Head, 1/2-13 by 1	11
5			601012271	Cap Screw, Hex Head, 1/2-13 by 1	9
6	679033107	679033107		Washer, Lock, 1/2-inch	11
6			679033107	Washer, Lock, 1/2-inch	9
7	457500069	457500007	457500069	Hinge Assembly, right hand*	1
8	457500070	457500008	457500070	Hinge Assembly, left hand*	1
9	657012641		657012641	Cap Screw, Hex Head, 1/2-13 by 1-3/4*	12
9		657012641		Cap Screw, Hex Head, 1/2-13 by 1-3/4*	16
10	679033107		679033107	Washer, Lock, 1/2-inch*	12
10		679033107		Washer, Lock, 1/2-inch*	16
11	643023007		643023007	Nut, Hex, 1/2-13*	12
11		643023007		Nut, Hex, 1/2-13*	16
12	621012271	621012271	621012271	Screw, Set, Socket, 1/2-13 by 1	4
13	757160011	757160026	757160011	Pin, Hinge	2
14	600134000	600134000	600134000	Fitting, Grease, Straight	6
15	657356334	657356334	657356334	Handle Grip	2
16	757280017	757280027	757280010	Counterweight and Rod Assembly	2
17	621012266	621012266	621012266	Screw, Set, Cup Point, 1/2-13 by 1/2	4

continued....

\* Items 7-11 included with Apron Assembly (Item 1)

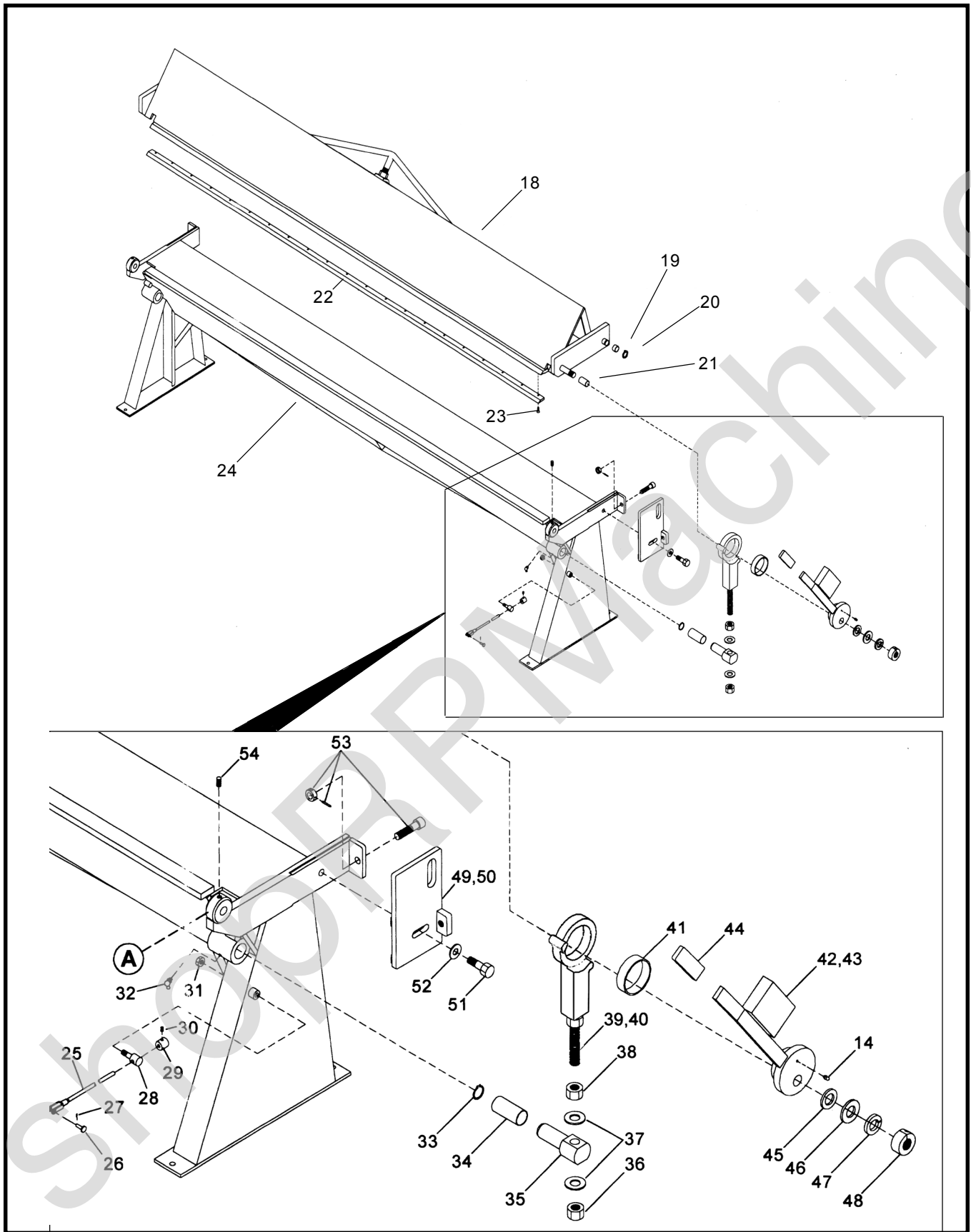

Figure 15. Exploded View of Replacement Parts

...continued from page 23

Ref. No.	Part Number			Part Name	Qty.
	Model 1018	Model 1016	Model 816		
18	257020007	257020001	257020004	Beam	1
19	757080015	757080056	757080015	Bushing, Slide Pin	2
20	656164302	600164307	656164302	Ring, Retaining, Slide Pin Bushing	2
21	457080076	457080009	457080076	Bushing, Eccentric (included with Items 42 and 43)	2
22	757030041	757030041	757030016	Radius Bar	1
23		613012131		Screw, Cap, Flathead, 5/16-18 by 3/4	21
23	613012131		613012131	Screw, Cap, Flathead, 5/16-18 by 3/4	17
24	257090008	257090002	257090005	Bed Assembly	1
25	757130036	757130036	757130036	Stop Rod, Apron	1
26	600083604	600083604	600083604	Pin, Clevis	1
27	600073516	600073516	600073516	Pin, Cotter, 3/32 by 1-inch	1
28	757160038	757160038	757160038	Stud, Apron Stop	1
29	757260072	757260072	757260072	Collar, Apron Stop	1
30	621012125	621012125	621012125	Screw, Apron Stop Collar, 5/16-18 by 5/16	1
31	666023007	666023007	666023007	Nut, Apron Stop Stud, Hex Nylock 1/2-13	1
32	600134006	600134006	600134006	Fitting, Grease, 45 Degree	2
33	657164324	657164322	657164324	Ring, Retaining	2
34	757080018	757080052	757080018	Bushing, Lower Toggle Pin	2
35	757160096	757160089	757160096	Pin, Lower Toggle	2
36	671023010	666023044	671023010	Toggle Nut, Lower - Nylock**	2
37	657033154	657033144	657033154	Washer, Spring	4
38	651023010	645023012	645023010	Toggle Nut, Upper**	2
39	757990015	757990028	757990015	Toggle Assembly, Right Hand	1
40	757990016	757990029	757990016	Toggle Assembly, Left Hand	1
41	757080009	757080053	757080009	Bushing, Toggle (installed in items 39 and 40)	
42	757030003	757030059	757030003	Clamping Lever, Right Hand	1
43	757030004	757030060	757030004	Clamping Lever, Left Hand	1
44	657356334	657356334	657356334	Handle, Grip	2
45	657245118	657245119	657245118	Bearing, Thrust	2
46	657033144	678033113	657033144	Washer	2
47	679033112	679033113	679033112	Washer, Split Lock	2
48	657000390	657000391	657000390	Collar, Clamping	2
49	757730005	757730001	757730005	Slide Plate, Right Hand	1
50	757730006	757730002	757730006	Slide Plate, Left Hand	1
51	611012410	611012410	611012410	Screw, Socket Head Cap, 3/4-10 by 1 1/2"	2
52	678033110	678033110	678033110	Washer, Clamping Screw	2
53	257940052	257940052	257940052	Adjusting Screw Assembly	2
54	617012266	617012266	617012266	Screw, Set, Socket Head, 1/2-13 by 1/2"	2

\*\* Included with Toggle Assemblies (items 39-40)

For your higher production jobs,  
Roper Whitney is  
pleased to offer.....

# Autobrake 2000

Offered in a range of models from 4-feet to 13-feet, and capacities through 1/4 mild steel, the Autobrake 2000 is designed to meet the needs of job shops, metal roofing contractors, and architectural sheet metal fabricators. These CNC metal folding systems incorporate automatic gauging, clamping, and pivot bending for versatile, efficient part production. Bending and gauge positioning accuracy allow a wide range of parts to be fabricated with repeat precision.

## Features of the Autobrake 2000 include:

- \* Precision backgauge with multiple stops for high-speed positioning of the work material.
- \* Integral material support table allows part production by a single operator, while reducing fatigue, and improving productivity.
- \* Flange-out pivot bending eliminates dangerous whip of the work piece.
- \* Easy-to-learn CNC controls allows part production the first day of operation.
- \* Clamping and bending beams driven from both ends provide consistent bends end-to-end as compared to systems driven from one end only.

