

PEXTO

NO. 137 & NO. 152
FOOT SQUARING SHEAR

INSTRUCTIONS AND PARTS IDENTIFICATION



ROPER WHITNEY

2833 HUFFMAN BLVD., ROCKFORD, ILLINOIS 61103-3990 * 815/962-3011 * FAX 815/962-2227

Website: www.roperwhitney.com * Email: info@roperwhitney.com

INSTRUCTIONS FOR ADJUSTING PEXTO FOOT SHEARS

-- BEFORE OPERATING --

Remove Shears From Skids and Log in Place

1. This shear has been tested to capacity at factory. Do not exceed rated capacity on nameplate.
2. To set up shear, remove from skids and place on level foundation. Back off all leg-to-bed bolts (19 & 20) and loosen adjusting screws (44) and (45). Bed must rest squarely on right and left hand leg ledges at all four corners when bolts are loose. If necessary, shim legs at the floor, to level bed on ledges. LAG SHEAR SECURELY TO FLOOR.
3. To adjust blade for cutting, (after setting up or changing blades), first make sure leg-to-bed bolts (19 & 20) are snug tight. CAUTION: Move bed toward crosshead blade by means of adjusting screws (44) and (45), screw (44) moves bed "out", increasing clearance between upper and lower blade - (45) moves bed "in", decreasing clearance. Position lower blade within a few thousandths of the upper blade, being careful that lower blade does not overlap the upper. Place a sheet of heavy paper (approx. .005") the full length of cut, between the blades and slowly depress the treadle. If shear does not cut paper, move bed blade in toward upper blade as necessary, by carefully readjusting screws (44 & 45) at either or both sides. If shear cuts paper on ends but not in center, it will be necessary to turn crosshead tie rod adjusting nut clockwise until paper cuts full length of blade. If shear cuts in center but not on ends, reverse direction of turn on crosshead tie rod adjusting nut.

NOTE: This adjustment is carefully made at the factory and should not be necessary on a new shear.

4. When blades are properly adjusted, tighten leg-to-bed bolts (19) securely before cutting stock.
5. Always keep blades sharp. Wiping blades occasionally with oil will increase blade life.
6. Lubrication should be maintained between crosshead and leg bearing surfaces. Lubricate all points (X) daily.
7. Front, back and side gauges are provided for use as required. Side and back gauges are graduated in sixteenths and adjustment is provided to keep graduations aligned with blade cutting edges.
8. Crosshead adjustment - use gib screws (48) to adjust gib setting. This setting should hold crosshead snugly against ways in legs (4 & 5), yet not bind the crosshead movement. This adjustment should not be necessary in new shear.
9. It is suggested that an extra pair of blades be available for use when blades are removed for sharpening. Blades should be returned to factory for regrinding.

10. Two leverage holes (A) are provided in each treadle lever arm for the lower connecting link pins. The treadle as shipped will give ample leverage for cutting soft steel within the rated capacity of the machine, but greater leverage can be obtained for cutting maximum capacity stock by moving the lower connecting link pins to the holes nearest the hinge pins.
11. To adjust shear after blades have been changed, back off the leg-to-bed bolts (19) and following instruction #3 above.

CAUTION: Use heavy gloves when handling shear blades.

12. When ordering replacement parts from the factory, be sure to give machine number, serial letter and part name.
13. Holddown adjustment - set holddown to engage sheet before blades.

MODELS 137 & 152 INSTRUCTIONS FOR INSTALLING SHEAR BLADES

To remove blades on the 137-152 Shear we ask that you follow the instructions listed below:

1. Unscrew the two holddown studs holding the holddown spring. Please make sure you take caution with the holddown spring because it is under tension.
2. Remove holddown spring, remove holddown to crosshead bolts (items 46 and 47). Remove holddown and set aside. Loosen bed to leg bolts (item 19) a half of a turn, loosen item 45 bed in adjusting screw two to three full turns, tighten item 44 bed out adjusting screw two to three full turns.

Place two blocks of wood between the upper and lower blades. Remove upper lade bolts and remove upper blade using extreme caution as to not cut your fingers with blade. Remove lower blade.

After regrinding the blade install upper and lower blades. Lower blade must be adjusted up flush with surface of bed, with square head adjusting screws located in bed blade seat.

Readjust shear to instructions on item no. 3 on instruction manual. Re-install the holddown and springs.

FOR SHARPENING MODEL 152 BLADE

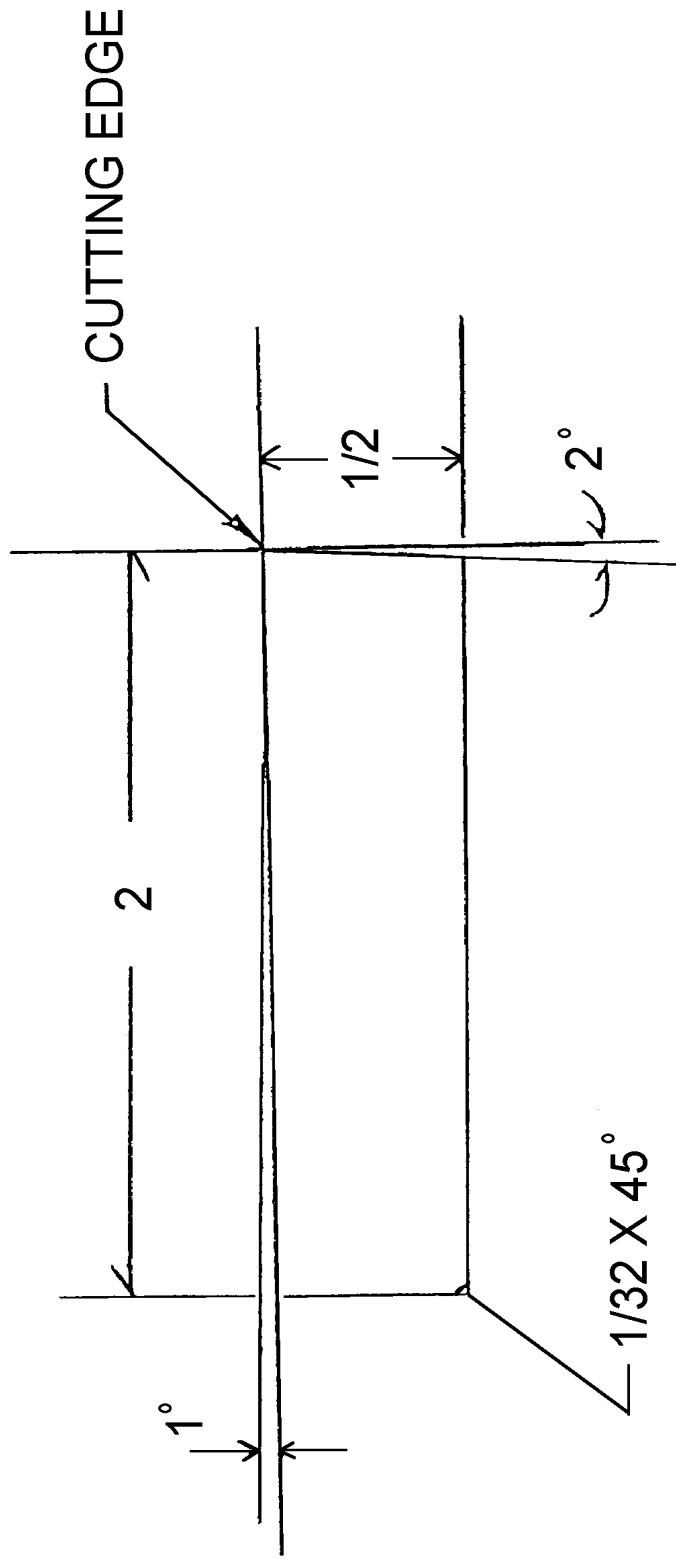

CUTTING EDGE AND THICKNESS

PARALLEL WITHIN .001 IN ANY 12"

PARALLEL WITHIN .003 OVERALL LENGTH

MODELS 137 & 152 PARTS IDENTIFICATION CHART

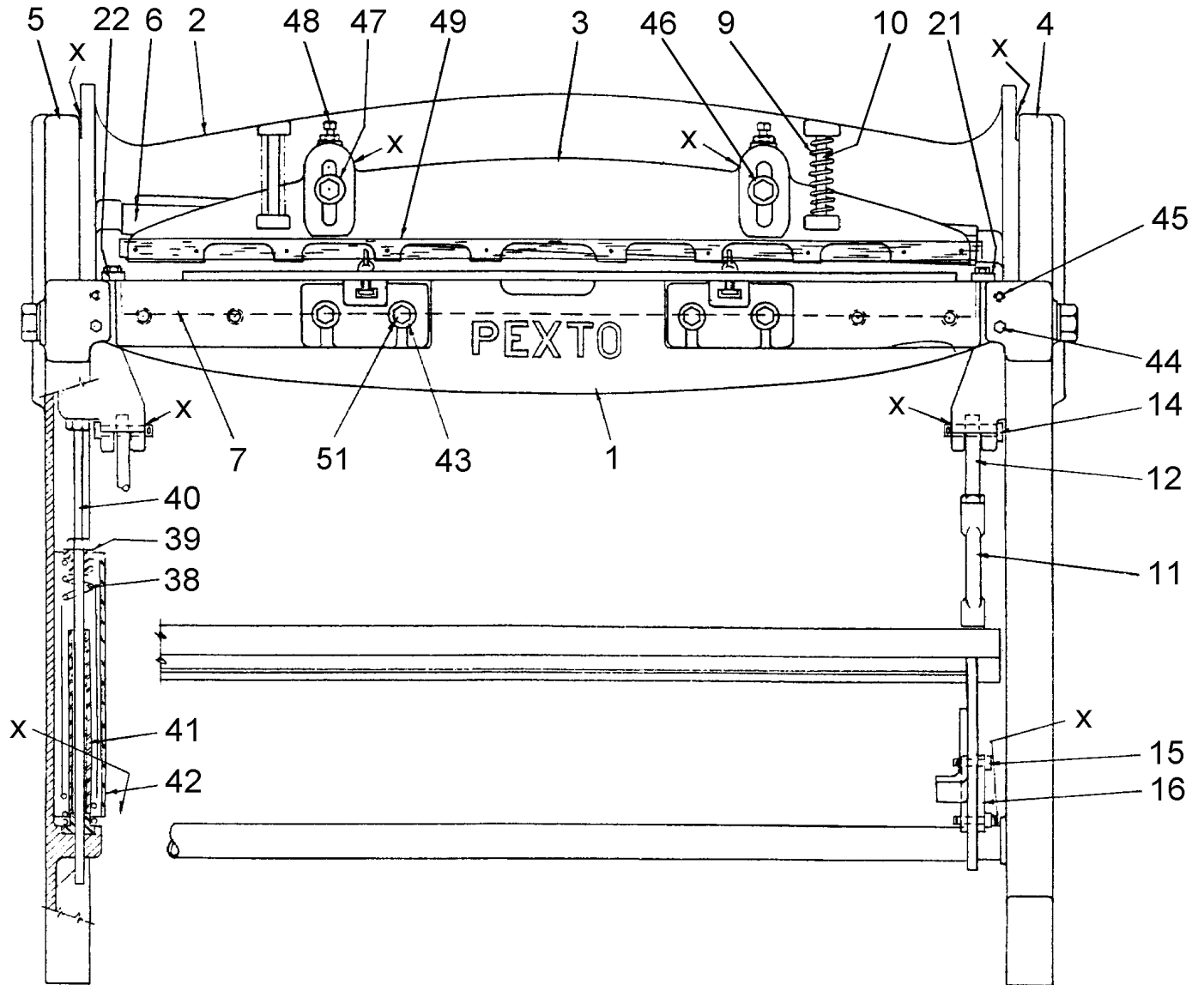

LUBRICATE POINTS X WITH SAE 30 OIL DAILY

MODELS 137 & 152 PARTS IDENTIFICATION CHART

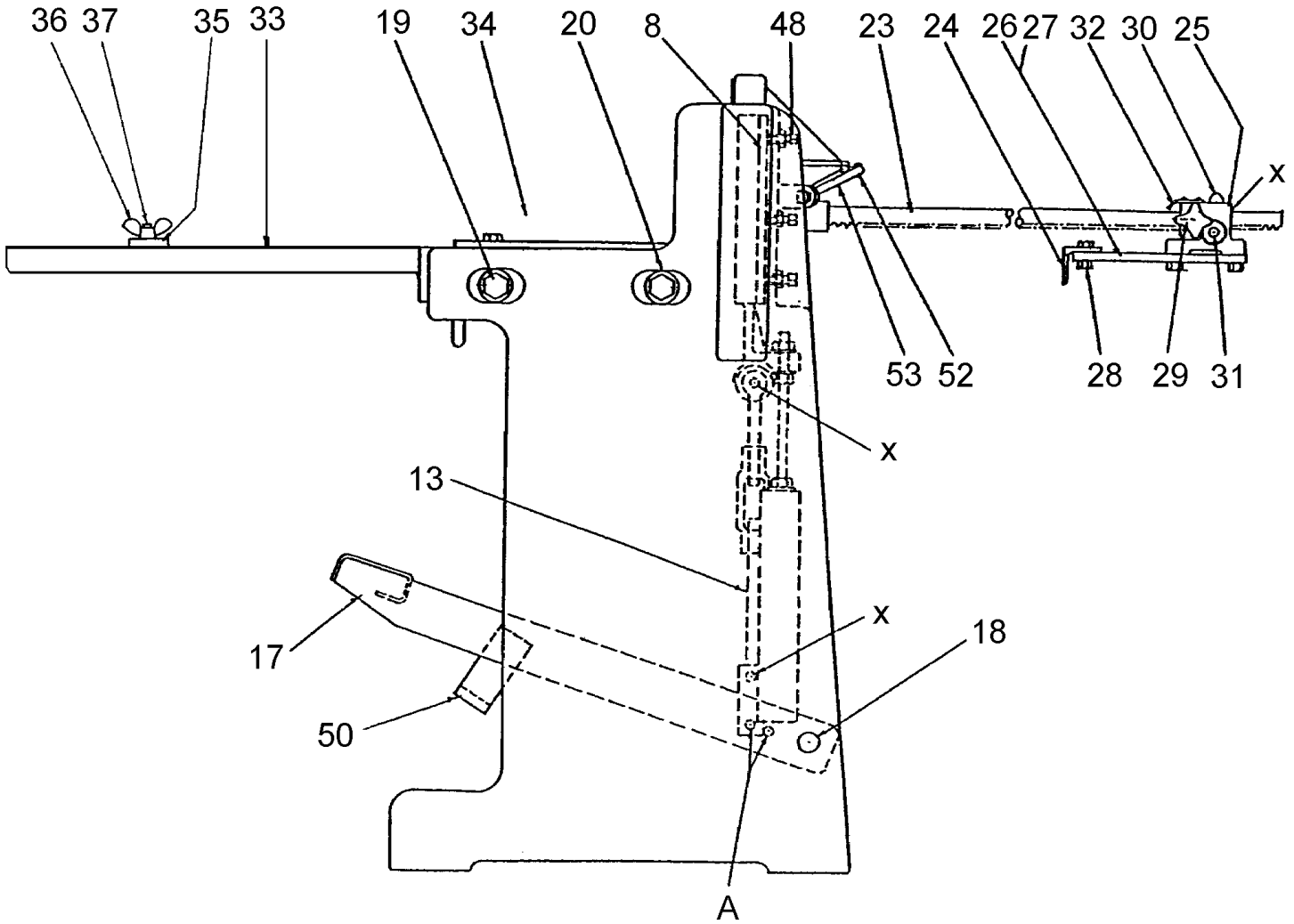

LUBRICATE POINTS X WITH SAE 30 OIL DAILY

**MODELS 137 & 152
PARTS IDENTIFICATION LIST**

ITEM NO.	MODEL 137 PART NO.	MODEL 152 PART NO.	PART NAME	NO. REQ'D
1	762090060	762090083	Bed	1
2	262940004	262940005	Crosshead Assembly	1
	(Crosshead Assembly consists of the following parts)			
	762610058	762610079	Crosshead	1
	762030059	762030002	Tie Rod	1
	762650003	762650003	Adjusting Screw	1
	643023009	643023009	Hex Full Nut, 5/8-11	1
	643023007	643023007	Hex Full Nut, 1/2-13	2
	678033107	678033107	Flat Washer, 1/2	2
	678033109	678033109	Flat Washer, 5/8	1
3	762010061	762010084	Holddown	1
4	762140069	762140069	R. H. Leg	1
5	762140070	762140070	L. H. Leg	1
6	350700190	350700193	Upper Blade	1
7	350700191	350700193	Lower Blade	1
8	762400071	762400071	Gib	2
9	662184546	662184548	Holddown Spring	2
10	762160062	762160085	Holddown Stud	2
11	600000125	600000125	Turnbuckles	2
12	600000126	600000126	Upper Treadle Rod	2
13	600000127	600000127	Lower Treadle Rod	2
14	762160250	762160250	Crosshead Pin	2
15	600000148	600000148	Connecting Link Pin	4
16	762240074	762240074	Connecting Link	4
17	762810063	762810080	Treadle Assembly	1
18	762160075	762160075	Treadle Hinge Pin	2
19	601012379	601012379	Bed to Leg Bolts	4
20	600033129	600033129	Washers	4
21	762420031	762420031	R. H. Side Gauge	1
22	762420032	762420032	L. H. Side Gauge	1
23	762030053	762030053	Backgauge Arm	2
24	762420057	762420056	Backgauge Bar	1
25	762200052	762200052	Backgauge Holder	2
26	762240054	762240054	R. H. Link	1
27	762240055	762240055	L. H. Link	1
28	762160051	762160051	Pivot Stud	3
29	600356311	600356311	Hand Knob	2

**MODELS 137 & 152
PARTS IDENTIFICATION LIST**

ITEM NO.	MODEL 137 PART NO.	MODEL 152 PART NO.	PART NAME	NO. REQ'D
30	762550049	762550049	Handwheel	2
31	762380050	762380050	Pinion	2
32	762420048	762420048	Pointer	2
33	762030257	762030257	Front Arm	2
34	762420034	762420034	Bevel Gauge	1
35	762420066	762420087	Front Gauge	1
36	673023007	673023007	Wing Nut	3
37	762160036	762160036	Tee Bolt	3
38	662184547	662184549	Treadle Spring	2
39	600000149	600000149	Spring Collar	4
40	762030077	762030077	Spring Rod	2
41	762450067	762450086	Spring Guide	2
42	600000192	600000192	Hose, Spring Guard	2
43	600033128	600033128	Washer	4
44	601012183	601012183	Bed Out Adjusting Screw	2
45	621012179	621012179	Bed In Adjusting Screw	2
46	601012277	601012279	R.H. Holddown to Crosshead Bolt	1
47	601012277	601012279	L.H. Holddown to Crosshead Bolt	1
48	633012181	633012181	Gib & Holddown Adjusting Screw	6
49	762440068	762440088	Finger Guard	1
50	On Treadle	On Treadle	Treadle Stop	
51	601012225	601012225	Front Arm Bolts	4
*52	See Crosshead Assembly			
*53	See Crosshead Assembly			
54	601012181		Lower Blade Screw (not shown)	6
55	601012177		Upper Blade Screw (not shown)	7
56	678033105		Upper & Lower Blade Washer (not shown)	13
57		601012181	Lower Blade Screw (not shown)	9
58		601012175	Short Upper Blade Screw (not shown)	7
59		601012179	Upper Blade Screw (not shown)	2
60		678033105	Upper & Lower Blade Washer (not shown)	18

NOTE: Part numbers are for current "L" Model for 137 Shear and the "K" Model for 152 Shear. All others please inquire. Always show serial number and model letter when ordering.

MODELS 137 & 152 BACKGAUGE IDENTIFICATION CHART

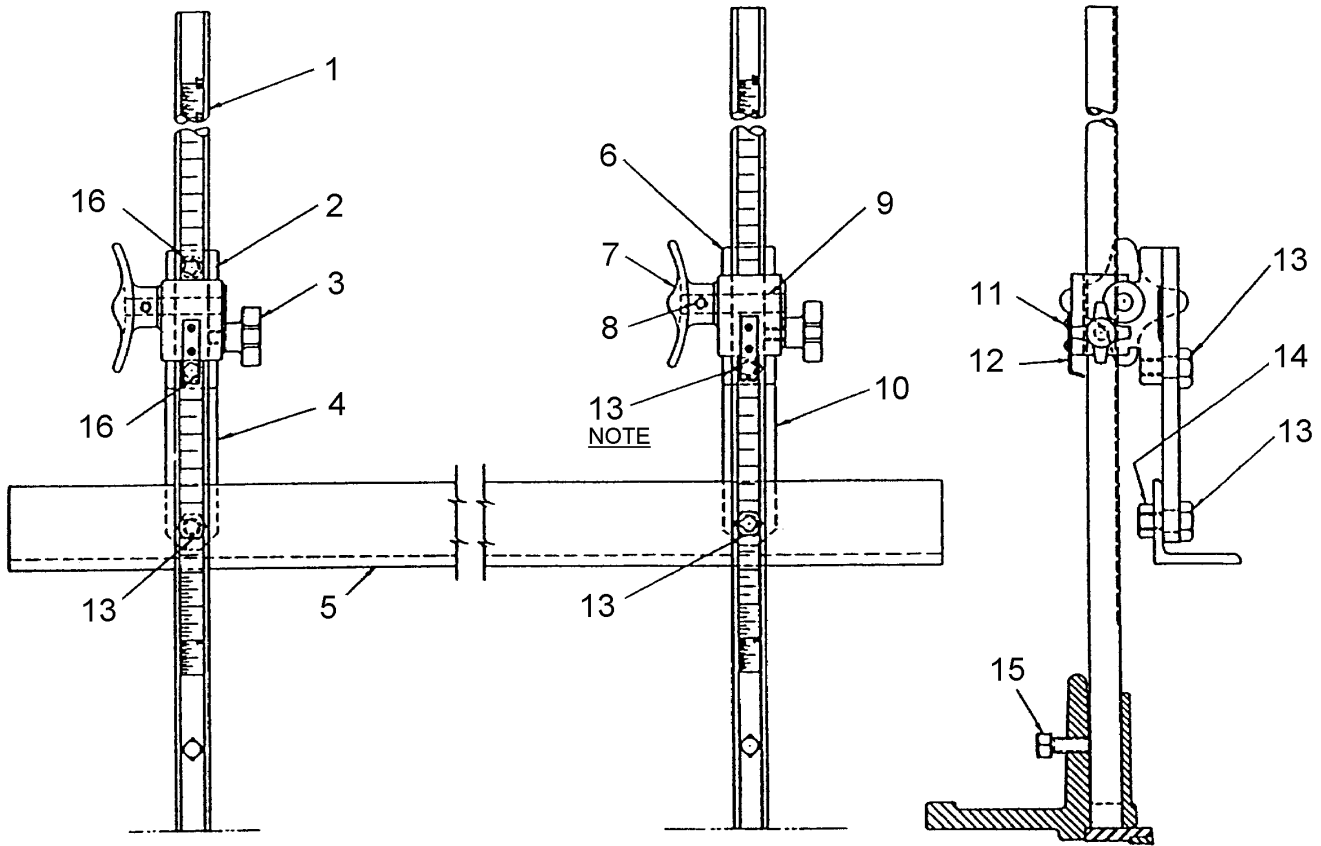

NOTE: R.H. LINK (10) IS ASSEMBLED TO R.H. GAUGE HOLDER (6) WITH ONE PIVOT STUD (13) TO PROVIDE FOR ANGULAR SETTING OF BACKGAUGE.

ITEM NO.	PART NO.	PART NAME	NO. REQ'D
1	762030053	Gauge Rod	2
2 & 6	762200052	Backgauge Holder	2
3	600356311	Hand Knob	2
4	762240055	L. H. Link	1
5	762420057	Backgauge Bar (137)	1
5	762420056	Backgauge Bar (152)	1
7	762550049	Handwheel	2
8	625012084	Allen Set Screw 1/4-20 x 3/8	2
9	762380050	Pinion	2
10	762240054	R. H. Link	1
11	615012024	Button Head Screw 8-32 x 1/4	4
12	762420048	Pointer	2
13	762160051	Pivot Stud	3
14	649023007	Hex Nut 1/2-13	2
15	621012273	SSCP Screw 1/2-13 x 1-1/4	
16	601012273	Hex Cap Screw 1/2-13 x 1-1/4	2

MODELS 137 & 152 FOOT SQUARING SHEAR LIMITED WARRANTY

All new Roper Whitney tools and machines are warranted, to the original purchaser for use, to be free of defects in material and workmanship for a period of one year from purchaser's date of purchase. Roper Whitney at its option will repair or replace, or refund the purchase price of, any tool or machine which falls within the warranty period and is found upon examination by Roper Whitney to be defective in material or workmanship, or both. This warranty does not cover failures attributable to improper use or maintenance, exceeding rated capacity, alteration, accident, or normal wear of moving parts. Accessories, controls, and hydraulic components not manufactured by Roper Whitney are excluded from this warranty. For services on such parts, refer to applicable manufacturer's warranty.

Purchaser must give written notice to Roper Whitney at the address below of any warrant claim within thirty days after failure, and if so instructed, return to Roper Whitney the parts to be replaced or repaired, with all transportation charges prepaid by purchaser. Replacement parts will be invoiced to purchaser, with credit issued for parts covered by this warranty and freight thereon. Removal and reinstallation of replacement parts shall be at purchaser's expense.

THERE IS NO OTHER EXPRESS WARRANTY, TO THE EXTENT PERMITTED BY LAW, ANY AND ALL IMPLIED WARRANTIES, INCLUDING MERCHANTABILITY AND FITNESS FOR PARTICULAR PURPOSE, ARE EXCLUDED: AND IMPLIED WARRANTIES NOT EXCLUDED ARE LIMITED IN DURATION TO ONE YEAR FROM DATE OF PURCHASE. INCIDENTAL AND CONSEQUENTIAL DAMAGES ARE EXPRESSLY EXCLUDED FROM THE REMEDIES AVAILABLE TO PURCHASER, AND THE REMEDIES PROVIDED IN THIS WARRANTY SHALL BE EXCLUSIVE TO THE EXTENT PERMITTED BY LAW.

(NOTE: Some states do not allow limitations on how long an implied warranty lasts or the exclusion or limitation of incidental or consequential damages, so the foregoing limitations and exclusions may not apply to you. This warranty gives you specific legal rights, and you may also have other rights which vary from state to state).

RETURN OF THE WARRANTY REGISTRATION CARD FURNISHED WITH THE PRODUCT PURCHASED IS NECESSARY TO OBTAIN WARRANTY COVERAGE THEREON. CARD MUST BE FULLY COMPLETED, SIGNED BY THE PURCHASER, AND IF APPLICABLE, SIGNED BY THE DISTRIBUTOR. RETURN REGISTRATION CARD TO:

ROPER WHITNEY
2833 Huffman Blvd., Rockford, IL 61103