

ROPER WHITNEY.®



**MODEL NO. STR 750
SQUARE TO ROUND DUCT FORMING MACHINE
OPERATION, PARTS & MAINTENANCE MANUAL**

Model:	Purchased From:
Serial #:	Date Received:

USA  MADE

An American Tradition Since 1910

Roper Whitney / 2833 Huffman Blvd. / Rockford, IL 61103 / 815-962-3011 / Fax 815-962-2227
www.roperwhitney.com

TABLE OF CONTENTS

WARRANTY.....	Page 3
SECTION 1: MACHINE INFORMATION.....	Page 5
SECTION 2: SAFETY INFORMATION.....	Page 9
SECTION 3: MACHINE ASSEMBLY & INSTALLATION.....	Page 17
SECTION 4: MACHINE FAMILIARISATION.....	Page 23
SECTION 5: MACHINE OPERATION.....	Page 31
SECTION 6: MACHINE MAINTENANCE	Page 41
SECTION 7: BASIC FAULT FINDING.....	Page 43
SECTION 8: ASSEMBLY DRAWING AND PARTS LIST.....	Page 45
SECTION 9: RECOMMENDED SPARES.....	Page 51

WARRANTY



Warranty Statement:

3 YEAR LIMITED WARRANTY

Roper Whitney ("Manufacturer") warrants, commencing with the date of shipment to first end-user ("Customer") and for a period of thirty-six (36) months thereafter, all machinery and parts manufactured by Manufacturer to be free of defects in workmanship and material. **This warranty remains in force for the above time period only if all of Manufacturer's operational procedures are followed and recommended maintenance is performed.** If, within such warranty period, any machinery or parts manufactured by Manufacturer shall be proved to Manufacturer's satisfaction to be defective, such machinery or parts shall be repaired or replaced, at Manufacturer's option. All warranty claims are made F.O.B Manufacturer's plant, providing such machinery or parts are returned freight prepaid to Manufacturer's plant or designated service center for Manufacturer's inspection. All failed parts or components must be returned to Manufacturer prepaid for inspection before credit will be issued for new parts or components. Manufacturer's obligation hereunder shall be confined to such repair or replacement and does not include any charges, direct or indirect, for removing or replacing defective machinery or parts. No warranty shall apply to machinery, or parts or accessories, which have been furnished, repaired, or altered by others so as, in Manufacturer's judgment, to affect the same adversely or which shall have been subject to negligence, accident or improper care, installation, maintenance, storage, or other than normal use or service, during or after shipment. No warranty shall apply to the cost of repairs made or attempted outside of Manufacturer's plant or designated service center without Manufacturer's authorization. No warranty shall apply with respect to machinery or part not manufactured by Manufacturer, including but not limited to motors, accessories, electrical and hydraulic components, if such machinery or part is subject to warranty by the manufacturer of such machinery or part. No warranty claims by Customer will be honored with respect to any machinery or part from which the name and date plate has been removed or is otherwise no longer located or exhibited on such machinery or part. **THE FOREGOING WARRANTIES ARE IN LIEU OF ALL OTHER WARRANTIES EXPRESSED OR IMPLIED, INCLUDING, BUT NOT LIMITED TO, ANY IMPLIED WARRANTY OF MERCHANTABILITY AND IMPLIED WARRANTY OF FITNESS FOR A PARTICULAR PURPOSE. MANUFACTURER SHALL NOT BE SUBJECT TO ANY OTHER OBLIGATIONS OR LIABILITIES WHATSOEVER WITH RESPECT TO MACHINERY, PARTS, ACCESSORIES, OR SERVICES MANUFACTURED OR FURNISHED BY IT OR ANY UNDERTAKINGS, ACTS, OR OMISSIONS RELATING THERETO. UNDER NO CIRCUMSTANCES SHALL MANUFACTURER BE LIABLE FOR ANY CONSEQUENTIAL OR OTHER DAMAGES, EXPENSES, LOSSES, OR DELAYS HOW SO EVER CAUSED. THERE ARE NO WARRANTIES THAT EXTEND BEYOND THE DESCRIPTION ON THE FACE HEREOF.**

Note: Consumable tooling is not covered under the 3 year manufacturer's warranty.

RETURN OF THE PRODUCT REGISTRATION CARD FURNISHED WITH THE PRODUCT IS NECESSARY TO OBTAIN WARRANTY COVERAGE THEREON. CARD MUST BE FULLY COMPLETED, SIGNED BY THE PURCHASER, AND IF APPLICABLE, SIGNED BY THE DISTRIBUTOR. RETURN REGISTRATION CARD TO:

Roper Whitney 2833 Huffman Blvd. Rockford, IL 61103
815-962-3011 / Fax 815-962-2227
www.roperswhitney.com

ShopRPM Machine

SECTION NUMBER

1

MACHINE INFORMATION



STR 750 EQUIPMENT BRIEF

The Square to Round Duct Forming Machine (STR 750) has revolutionised square to round duct forming.

Duct fittings can be made quickly and easily, ensuring production in other areas is not interrupted or slowed down, ensuring your main folding equipment is free to do other work.

This compact and very very versatile machine will form a square to round duct fitting under two minutes from a flat blank, generally resulting with only one joint to be made and no reshaping being required .

The machines versatility together with its mobility make it ideal for on-site work.

Below and on the following page are shown some samples of the finished product

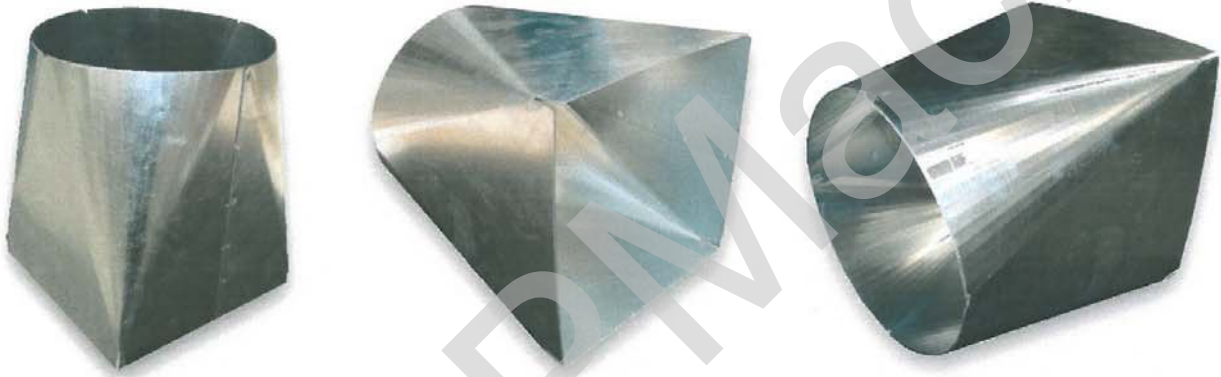

IN-LINE SQUARE TO ROUND- WITHOUT FLANGE



IN-LINE SQUARE TO ROUND- WITH FLANGE

STR 750 EQUIPMENT BRIEF



IN-LINE RECTANGULAR (WITH ROUNDED CORNERS) TO ROUND- WITH FLANGE



IN-LINE RECTANGULAR TO ROUND- WITH FLANGE



OFFSET SQUARE TO ROUND- WITH FLANGE

STR 750 SPECIFICATIONS

MACHINE: Square to Round Duct Forming Machine STR 750.

MACHINE DIMENSIONS: 41.3" Wide (1050 mm) x 24.4" Deep (620mm) x 43.3" High (1100mm).

MACHINE WEIGHT: 176.37 lbs (80 Kilograms).

AIR REQUIREMENT: 6 to 7 Bar, Regulated and filtered clean air.

MATERIAL GAUGE: 0.6mm to 1.2mm (European)/ up to 18 gauge metal thickness (USA).

PATTERN: The maximum creasing length of the Square to Round pattern is 29.5" (750mm).

The STR 750 machine is capable of making offset pieces as well as in-line square to round pieces.

DIAMETER: The minimum diameter is 4" (100mm).

SHIPPING CRATE WEIGHT: 200 lbs (91 Kilograms).

SECTION NUMBER

2

SAFETY INFORMATION



SAFETY INFORMATION

GENERAL

It is the responsibility of the customer to ensure that future operators and maintenance personnel are fully trained in the correct use, upkeep and maintenance of the machine and that this practice is maintained throughout its working life. It is recommended that each operator take the time to read through this manual in full before operating the machine.

IMPORTANT!

The safety instructions contained in this section must be followed at all times. It is important that all safety devices provided with the machine are always fully operational and that all guarding is in place and secured before the machine is operated.

SAFETY FEATURES

1. Removable guards are provided at strategic points on the machine. Their removal should be strictly restricted/limited to future maintenance activities.
2. All guards removed should be replaced as soon as any of the above activities have been completed.



SAFETY FEATURES CONTINUED

3. The shrouded foot operated pneumatic switch will only operate when an operators foot is fully engaged on and into the foot pedal.



POTENTIAL PINCH POINT

While in the design of the STR 750 Duct Forming Machine the blade guards cover the creasing area when in operation it is advised that operators as a matter of course, keep their hands clear from this area when the machine is operated.



MANUAL HANDLING

Some of the flat packed STR 750 Duct Forming machine parts are heavy and require care when handled manually.

There are some basic principles that everyone should observe, prior to carrying out a manual handling operation:

1. Ensure that the object is light enough to lift, is stable and is unlikely to shift or move.
2. Heavy or awkward loads should be moved using a handling aid.
3. Make sure that the route to be taken is clear of obstructions.
4. Stand as close to the load as possible and spread your feet to shoulder width.
5. Bend your knees and try and keep the back's natural upright position.
6. Grasp the load firmly as close to the body as you can.
7. Use the legs to lift the load in a smooth motion as this offers more leverage, reducing the strain on your back.
8. Carry the load close to the body with the elbows tucked into the body.
9. Avoid twisting the body as much as possible by turning your feet to position yourself with the load.

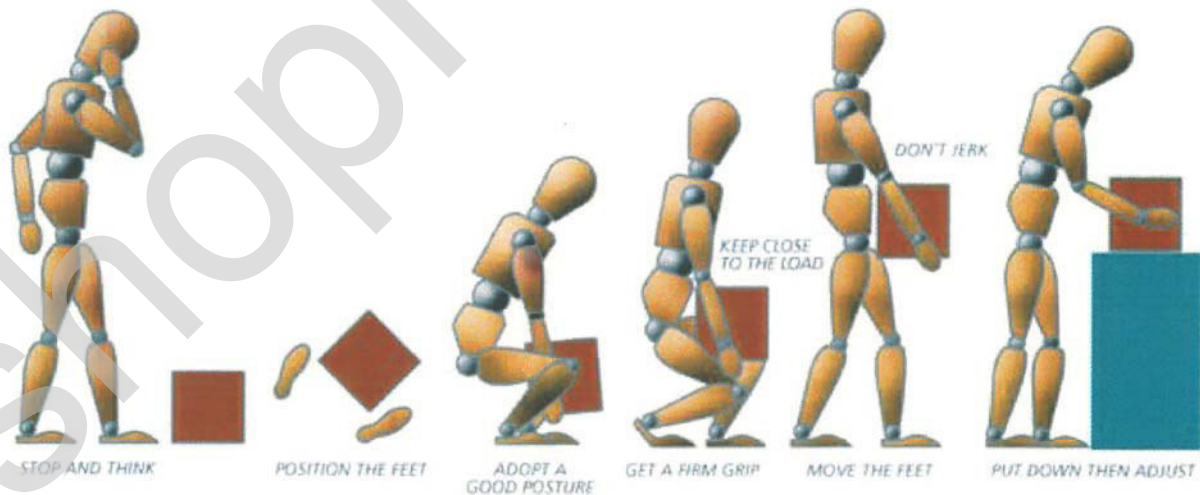

PERSONAL PROTECTIVE EQUIPMENT (PPE)

The Personal Protective Equipment at Work Regulations 1992 require all employers to self assess the health and safety risk to their employees and, where appropriate, provide them with suitable personal protective equipment. Legislation demands that each employee be fully trained in the use of any such PPE supplied.

The following personal protective equipment (but not limited to) has been identified as being required when operating the STR 750 Duct Forming Machine.

1. Appropriate protective overalls.
2. Safety boots with steel protective toe caps and souls.
3. Appropriate safety gloves for handling sheet steel etc.

SAFETY GUIDELINES

MECHANICAL:

1. Read the machine manual before operating the machine.
2. Use the machine only for its intended purpose.
3. The machine should be installed in a cool dry area.
4. Avoid build up of scrap, debris and off cuts etc around moving components.
5. Do not operate the machine if any mechanical damage or wear has occurred.
6. Do not leave inexperienced operators unsupervised.
7. Keep hands away from moving components.
8. Keep machine clean and in optimum working condition for efficient and safe operation.
9. Ensure access to the machine is clear at all times.

GENERAL SAFETY CONSIDERATIONS WHEN USING COMPRESSED AIR

USING COMPRESSED AIR TO CLEAN:

1. If allowed by the company, compressed air may be used to clean hard-to-reach areas as long as safety procedures are followed.
2. When using compressed air for cleaning, you must use an air nozzle that allows no more than 30 pounds per square inch of pressure. Since most air lines range in pressure from 90 psi to 120 psi, a pressure-reducing nozzle must be used.
3. In addition, a “dead man” switch or constant pressure trigger must be used to stop air flow once the nozzle is released.
4. One danger of cleaning with compressed air is particles and debris flying back into the face of the operator.
5. To reduce this hazard, some air guns are equipped with chip guards or provide an “air curtain” around the nozzle to help reduce fly back.
6. These types of devices do not offer complete protection. Proper protective equipment should always be worn when cleaning with compressed air.
7. Safety goggles offer better protection than regular safety glasses. In addition, a face shield should also be worn for complete facial protection.
8. Once you have protected yourself by using an approved nozzle and wearing the proper PPE, you must make sure to protect the other workers in your area.

CLEANING OFF THE BODY WITH COMPRESSED AIR:

1. Blowing dust and dirt off of clothes, hair and the face is a very hazardous misuse of compressed air. This practice is very dangerous and is not permitted under any circumstances.
2. Contact with compressed air can lead to serious medical conditions and even death. Our mouths, ears and eyes are very sensitive and can be easily damaged by compressed air.
3. Don't be fooled into thinking that safety nozzles which regulate pressure to 30 psi can be safely used to clean the human body. Even 30 psi is too much pressure for these sensitive areas.
4. As little as 12 pounds of pressure can blow an eye out of its socket. Compressed air entering the mouth can rupture the oesophagus with as little as 5 pounds of pressure.

CLEANING OFF THE BODY WITH COMPRESSED AIR CONTINUED

5. When compressed air enters the ear canal, serious damage can occur that may lead to permanent hearing loss.
6. Perhaps the most serious type of air-related injury occurs when compressed air is blown under the skin. Known as an air embolism, this type of injury can be fatal.
7. When an air pocket reaches the heart, it causes symptoms similar to a heart attack. Upon reaching the brain, pockets of air may lead to a stroke.
8. Because compressed air contains small amounts of oil and other contaminants, anytime compressed air is blown under the skin these contaminants enter the body and may cause dangerous infection.

INSPECTING COMPRESSED AIR EQUIPMENT

1. Before using compressed air equipment, always inspect it and make sure every thing is in good working order.
2. Hoses should be checked carefully for any sign of damage. Air hoses with cracks or other damage should be removed from service.
3. Air fittings and couplings should also be inspected, they should fit tightly into the hose and be clamped securely with an approved machine clamp.
4. If your couplings require locking pins, make sure they are in place before use.
5. Using compressed air with loose or improper fittings can be dangerous and lead to serious injury. If a connection blows out, a hose can begin whipping violently.

ShopRPM Machine

SECTION NUMBER

3

MACHINE ASSEMBLY & INSTALLATION



STR 750 ASSEMBLY

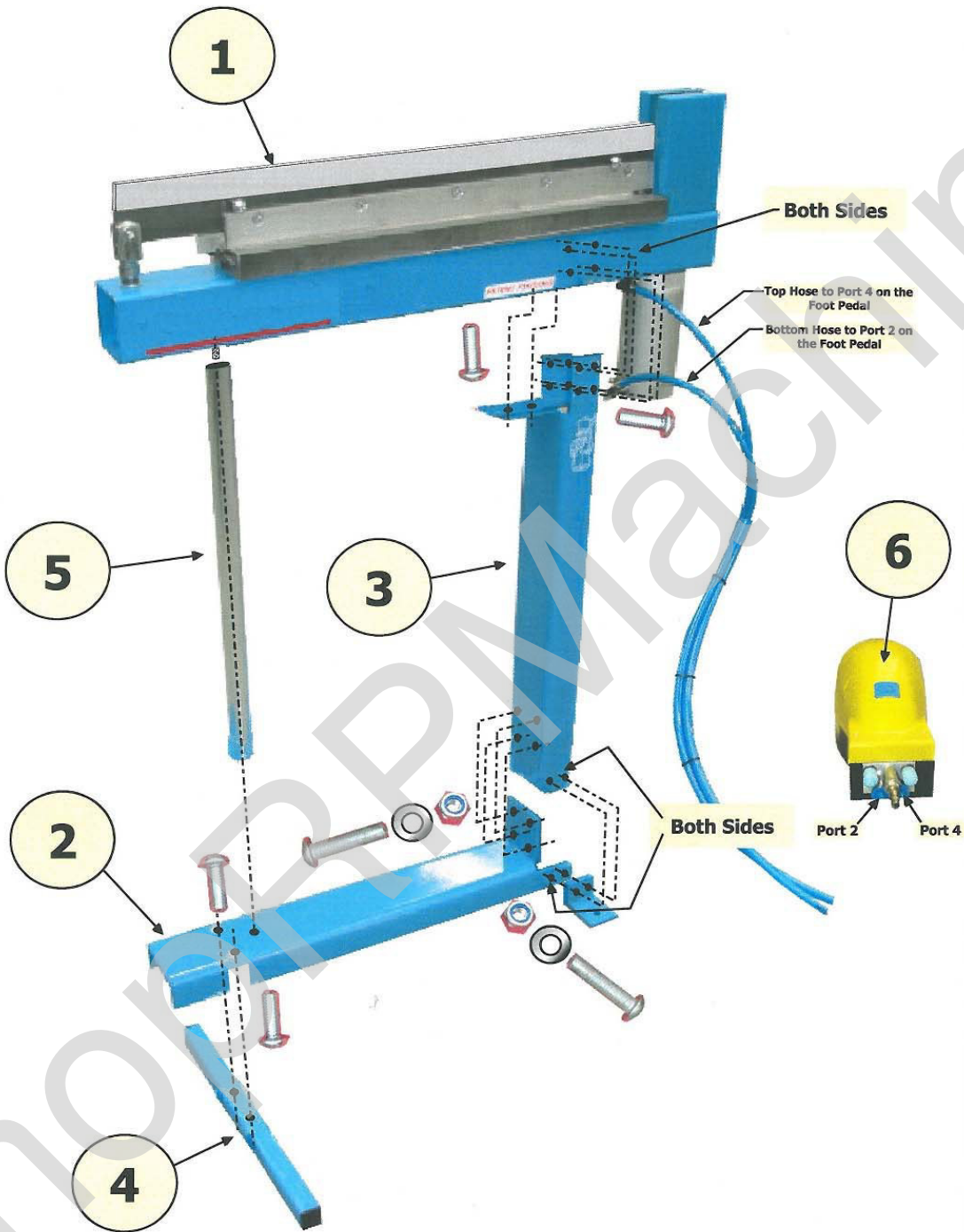







 Fully assembled STR 750 Duct Forming Machine from flat packed.

STR 750 ASSEMBLY INSTRUCTIONS

The STR 750 machine is delivered flat packed and the following instructions in conjunction with the exploded view opposite should be followed.

After removing the various parts from the packaging, identify them against the parts shown in the figure opposite. (Report any shortages immediately).

1. Attach item 4 to item 2 with the fixing hardware provided. 
(This immediately adds stability to the machines base channel).
2. Attach item 3 to item 2 with the fixing hardware provided. 
3. Screw item 3 onto the stud attached under item 1.
4. Lift and place item 1 onto item 3 ensuring that the fixing holes on each side and underneath line up with each other. Secure both these items together with the fixing hardware provided. 
5. Attach item 5 to item 2 by carefully tipping the machine upwards at the folder blade hinge end to gain access to the fixing hole in the machines base channel. Secure with the fixing hardware provided,  screwing it into the tapped hole in the bottom of the item.
6. Connect the pneumatic cylinder air lines to the appropriate connections on item 6.
NOTE! Connect the cylinder top hose to port 4 on the foot pedal and the bottom hose to port 2.

STR 750 INSTALLATION

For optimum performance it is recommended that the following points are considered.

1. The environment where the machine is to be installed should be safe, clean and dry.
2. The immediate and surrounding area should be well lit.
3. An appropriate compressed air supply must be available (6 to 7 Bar Regulated and Filtered clean air.)

LIFTING

The STR 750 machine should be lifted via two people or a suitably rated fork lift truck (the weight of the STR 750 is 176 lbs.)

SECURITY AND LEVELLING

It is very important that the machine is secured (provision is made to accommodate two anchor type floor bolts) and levelled correctly to ensure it is free from any distortion.

NOTE! Do not attempt to operate the machine until it is secured and levelled.

**Machine to Floor
Securing Points**



STR 750 INSTALLATION



Connect the pneumatic hoses from the cylinder to the foot pedal. Top hose to Port 4, Bottom hose to Port 2.



Push the end of each hose into the connector on the foot pedal. Ensure they are fully inserted into each connector.

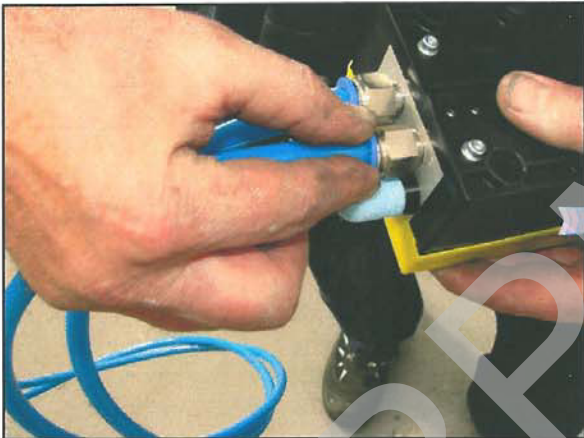

In the event a hose has to be disconnected, grip the hose and push the blue plastic flange of the connector inwards.



This action releases the hose which should be pulled out of the connector.



With the cylinder to foot pedal pneumatic connections made engage the main air in hose line with the air in connector on the foot pedal.



The above picture shows all the pneumatic connections to the foot pedal made/completed.

ShopRPM Machine

SECTION NUMBER

4

MACHINE FAMILIARISATION



STR 750 MACHINE EQUIPMENT FAMILIARISATION INDEX

SIDE VIEW OF THE STR 750 MACHINE.

STR 750 MACHINE AS VIEWED FROM THE PNEUMATIC CYLINDER END.

STR 750 MACHINE AS VIEWED FROM THE CLEVIS END.

PART VIEW OF THE STR 750 MACHINE AS VIEWED FROM THE CLEVIS END.

PART VIEW OF THE STR 750 MACHINE AS VIEWED ON THE BOTTOM FORMING DIE SET.

ShopRP Machine

STR 750 MACHINE EQUIPMENT FAMILIARISATION

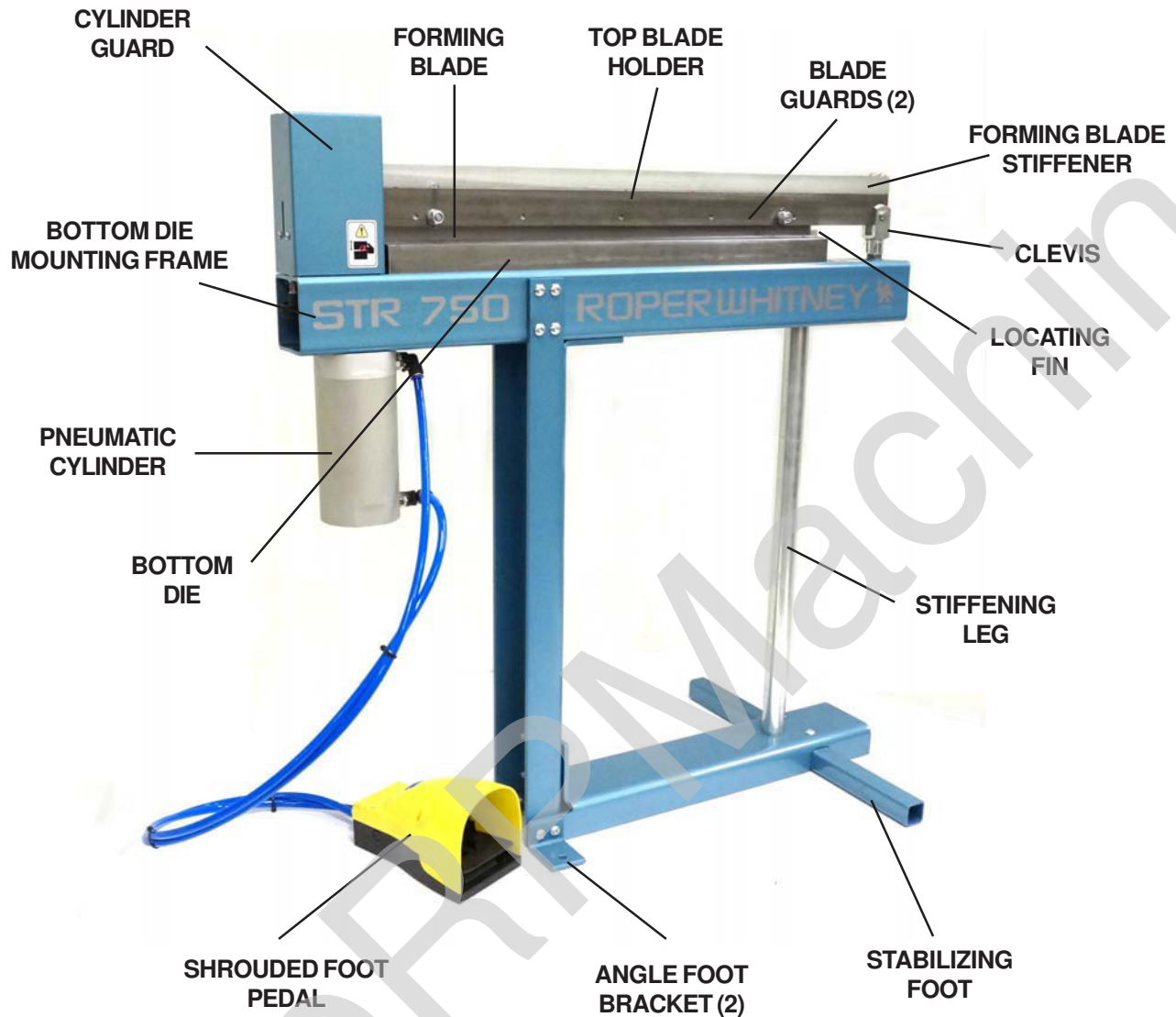

SIDE VIEW OF THE STR 750 MACHINE

STR 750 MACHINE EQUIPMENT FAMILIARISATION



STR 750 MACHINE AS VIEWED FROM THE PNEUMATIC CYLINDER END

STR 750 MACHINE EQUIPMENT FAMILIARISATION

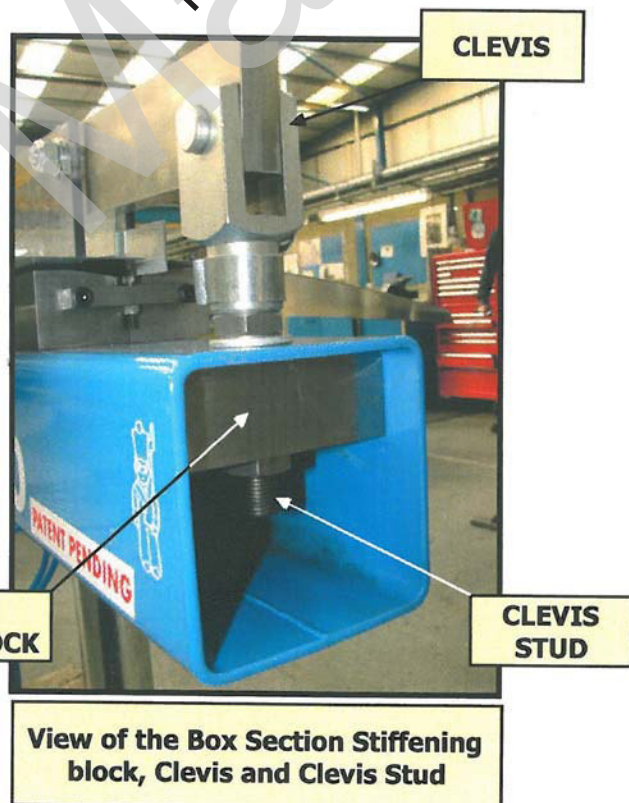

STR 750 MACHINE AS VIEWED FROM THE CLEVIS END

STR 750 MACHINE EQUIPMENT FAMILIARISATION

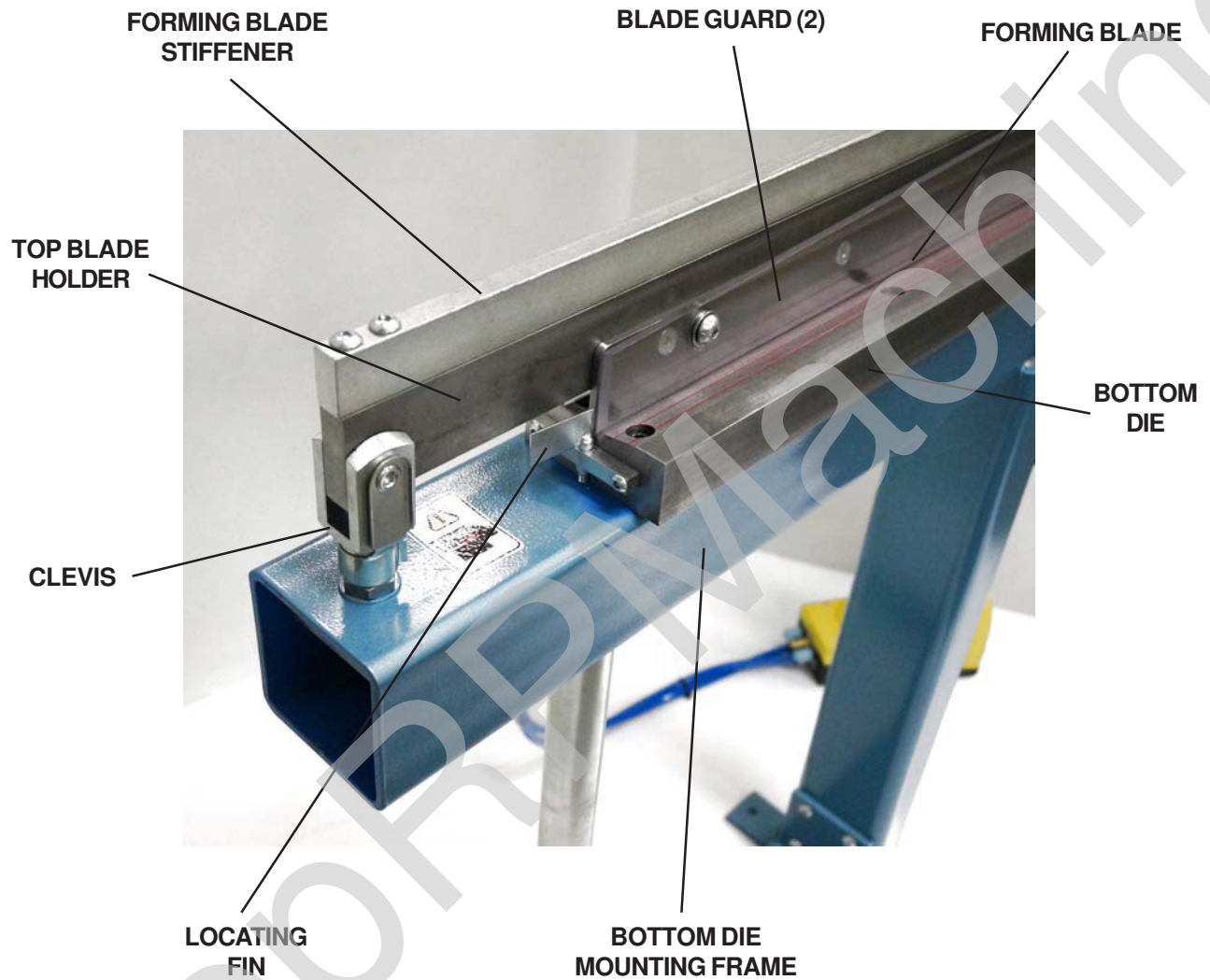

**PART VIEW OF THE STR 750 MACHINE
AS VIEWED FROM THE CLEVIS END**

STR 750 MACHINE EQUIPMENT FAMILIARISATION

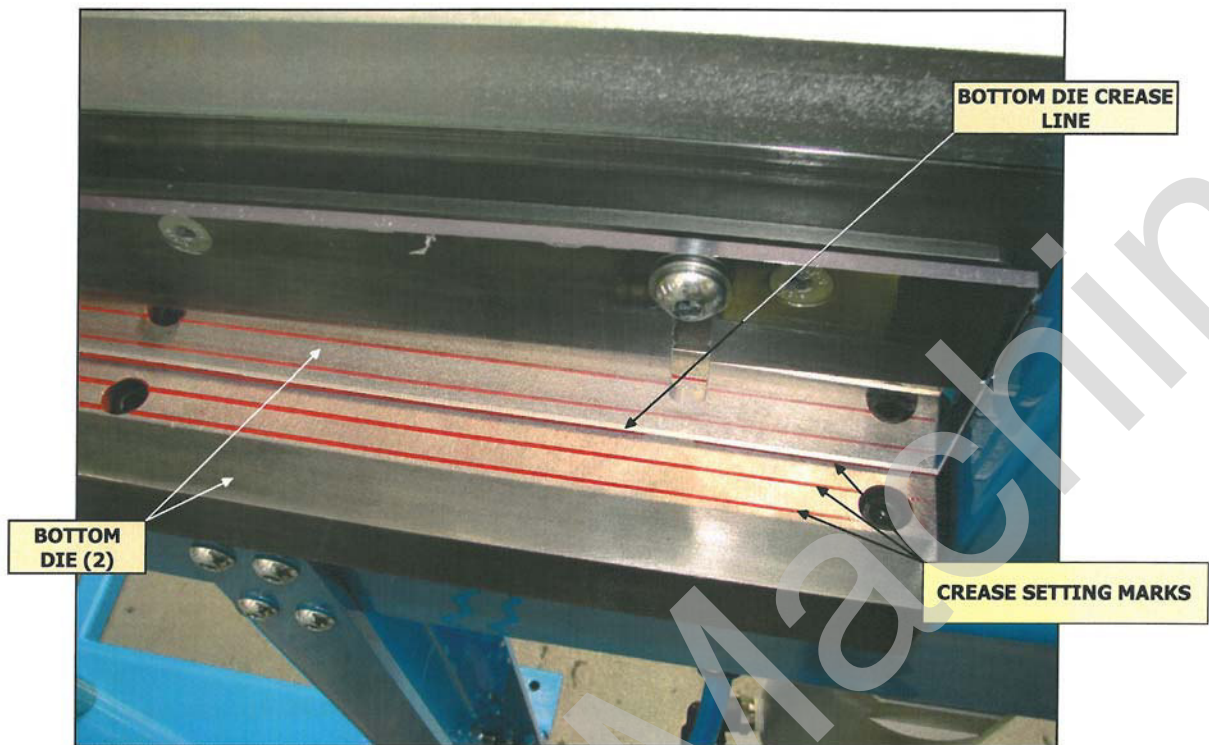

PART VIEW OF THE STR 750 MACHINE
AS VIEWED ON THE BOTTOM FORMING DIE SET

ShopRPM Machine

SECTION NUMBER

5

MACHINE OPERATION



STR 750 MACHINE OPERATION

PREPARATION/SETUP & OPERATION

PREPARATION

IMPORTANT! Prior to any machine operation the following actions should be taken:

1. Ensure that all the machine areas are clear and free from any obstructions.
2. Ensure that all the machine guards are fitted and are in good order.
3. Make sure that there are no liquid spills around the machine or trailing leads, that may lead to slips, trips and falls.
4. Wear the appropriate (PPE) personal protection equipment.

The following personal protective equipment (but not limited to) has been identified as being required when operating the STR 750 Machine.

Appropriate protective overalls.

Safety boots with steel protective toe caps and soles.

Appropriate safety gloves for handling sheet steel etc.



STR 750 DUCT FORMING MACHINE - SQUARE TO ROUND SIZE SCHEDULE.

square end size	round end size	equal	offset	22 gauge length	20 gauge length	18 gauge length	pitch marker line
100 x 100 to 400 x 100	100 dia	yes	yes	350 mm	300 mm	N/A	1
150x 150 to 400 x 150	150 dia	yes	yes	450 mm	400 mm	N/A	1.5
200 x 200 to 400 x 200	200 dia	yes	yes	550 mm	500 mm	N/A	2
250 x 250 to 500 x 250	250 dia	yes	yes	650 mm	600 mm	N/A	2.5
300 x 300 to 600 x 300	300 dia	yes	yes	700 mm	700 mm	600 mm	3
350x 350 to 700 x 350	350 dia	yes	yes	650 mm	650 mm	600 mm	adjust + half turn
400 x 400 to 800 x 400	400 dia	yes	yes	600 mm	600 mm	600 mm	adjust + 1 turn
450 x 450 to 800 x 450	450 dia	yes	yes	600 mm	600 mm	600 mm	adjust + 1.5 turn
500 x 500 to 800 x 500	500 dia	yes	yes	600 mm	600 mm	600 mm	adjust + 2 turn
550 x 550 to 800 x 550	550 dia	yes	yes	600 mm	600 mm	600 mm	adjust + 2 turns
600 x 600 to 800 x 600	600 dia	yes	yes	600 mm	600 mm	600 mm	adjust + 2.5 turns
750 x 750 to 800 x 750	750 dia	yes	yes	600 mm	600 mm	600 mm	adjust + 2.5 turns
800 x 800	800 dia	yes	yes	600 mm	600 mm	600 mm	adjust + 3 turns

Relate to the diameter size for the duct length if you wish the circle to be bigger than the square end

Minimum re- shaping may be needed in some hard setting items

SHEET METAL GAUGE CONVERSION CHART

IMPERIAL GAUGE	IMPERIAL IN MM	METRIC SHEET MM
18	1.22	1.2
20	0.91	0.9
22	0.71	0.7

ShopRPMMachine

STR 750 MACHINE OPERATION

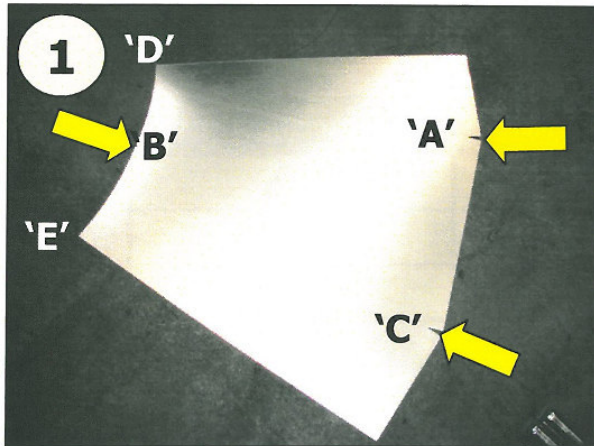

Above is shown the pattern to produce one half of an in-line rectangular to round duct.

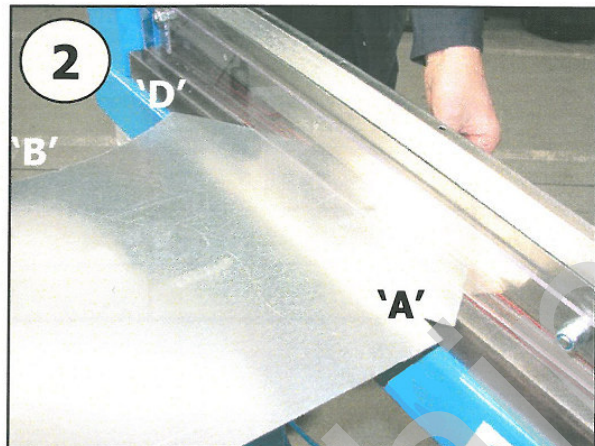

Place the flat pattern under the Forming blade as shown above.

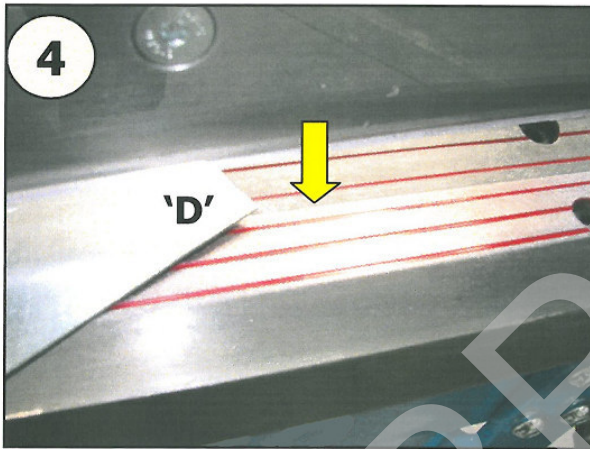

Position the corner 'D' with the bottom die crease line, as shown above.

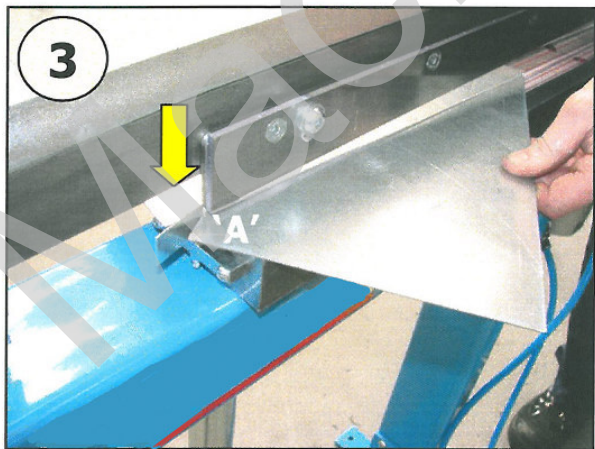

Position the notch ref 'A' up to and into the locating fin.



With both positions set correctly, press the foot pedal to form the first crease.

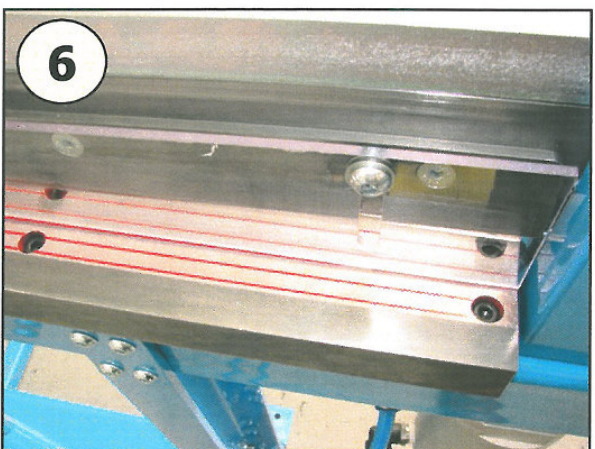

The above picture shows the crease setting marks on the bottom die set.

STR 750 MACHINE OPERATION CONTINUED

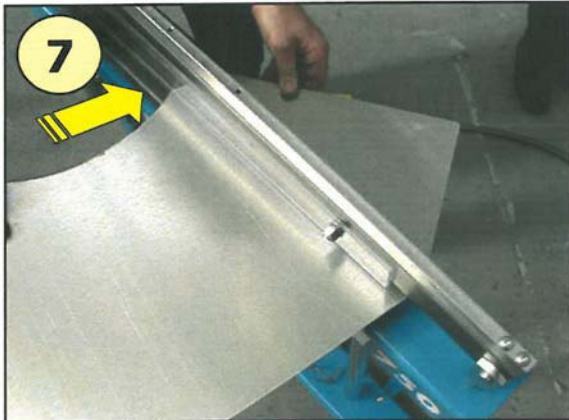

With the first crease completed, push the pattern under the open forming blade and align it with the appropriate outer alignment mark, press the foot pedal to complete the second crease.

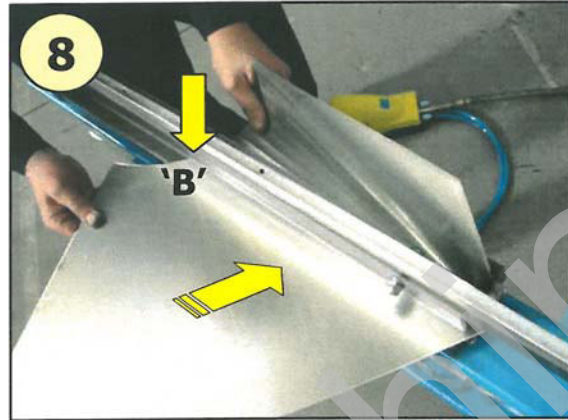

Continue to move the pattern inwards and applying creases until the notch 'B' is reached and apply the final crease on this side of the pattern.



Position the notch ref 'C' up to and into the locating fin.

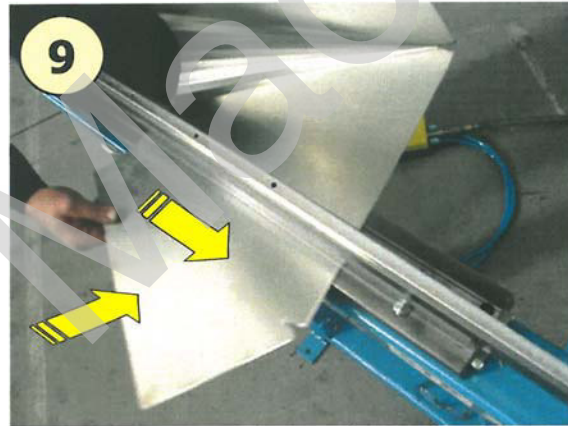

With the final crease on this side completed move the pattern away at notch 'A' from the locating fin, pushing the pattern forward under the open forming blade.

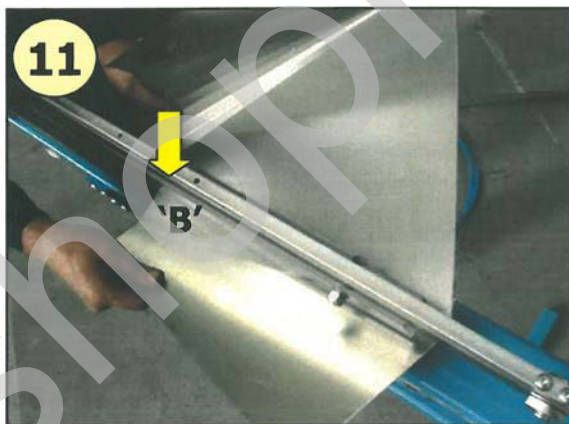

Position the notch ref 'B' with the bottom die crease line, as shown above and press the foot pedal to form the first crease on this side of the pattern.

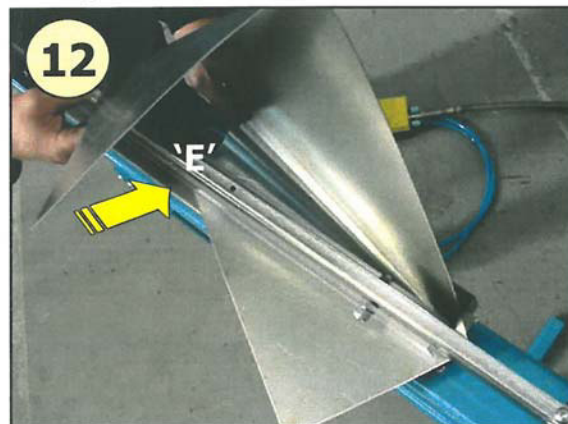

With the first crease completed, continue to move the pattern inwards using the alignment marks for each crease until corner 'E' is reached and the final crease is made.

STR 750 MACHINE OPERATION CONTINUED

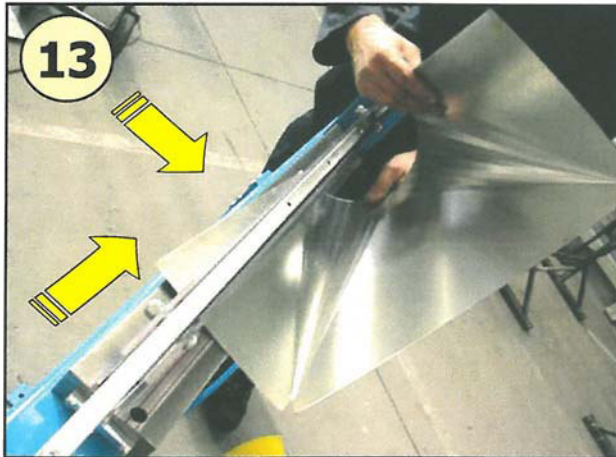

With all creases complete move the half formed duct piece away and out of the locating fin.

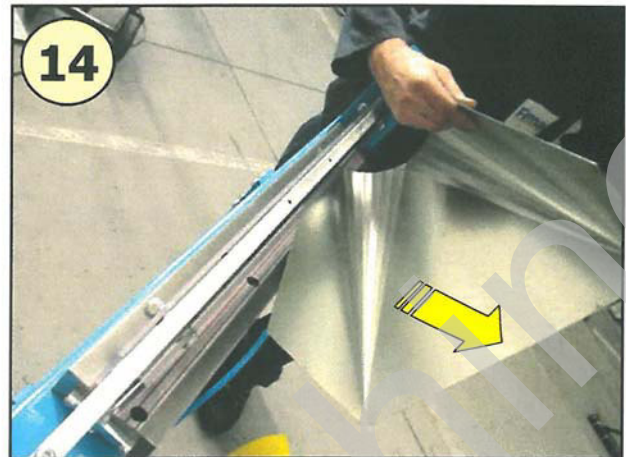

Remove the half completed duct piece away and from under the forming blade.

16



The picture above shows the two halves of the in-line rectangular to round, spot welded together with flanges and corner pieces.



The picture above shows one half of the in-line rectangular to round duct completed.

STR 750 MACHINE OPERATION CONTINUED

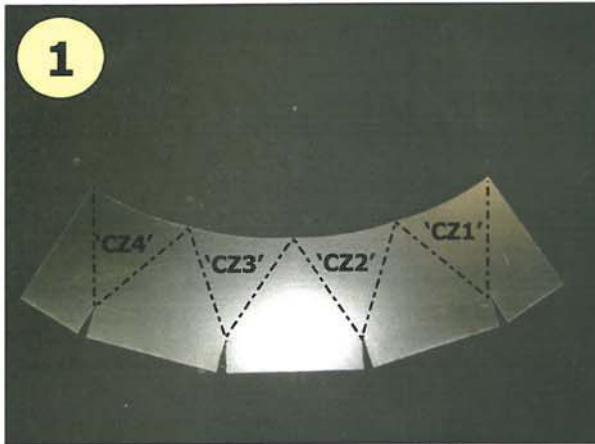

Above is shown the pattern to produce one full in-line square to round (crease zones are shown as 'CZ1', 'CZ2', 'CZ3' and 'CZ4')

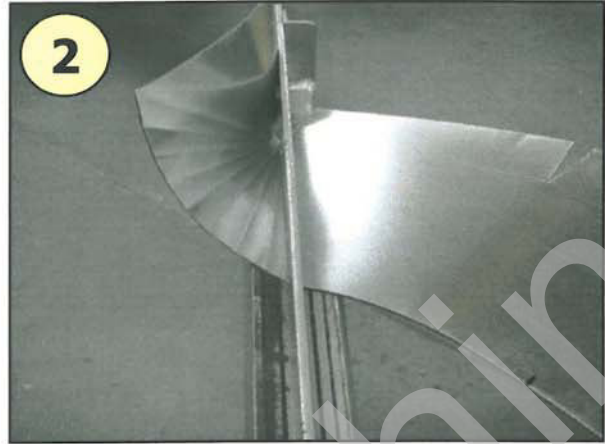

The above picture shows the forming taking place of the 'CZ1' zone.

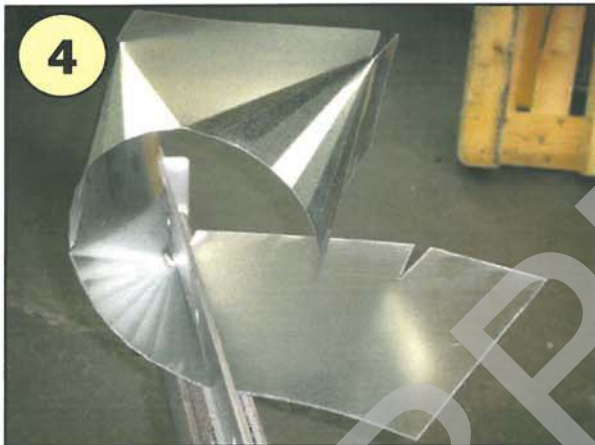

The above picture shows the forming taking place of the 'CZ3' zone.



The above picture shows the forming taking place of the 'CZ2' zone.



The above picture shows the forming taking place of the 'CZ4' zone.

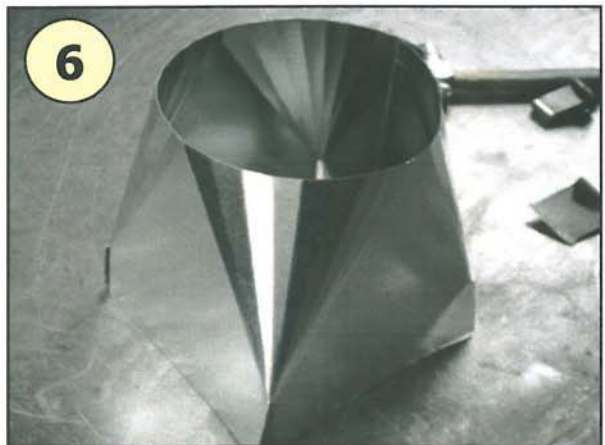

The above picture shows the completed in-line square to round.

STR 750 MACHINE OPERATION CONTINUED



7

The picture above shows the completed in-line square to round, spot welded together with flanges and corner pieces .

ShopRPM Machine

BASIC MAINTENANCE ROUTINES



STR 750 MACHINE BASIC MAINTENANCE ROUTINES

LOCATION	LUBRICATION	MAINTENANCE ACTION	FREQUENCY
General	Not Applicable	Before use, check for obstructions, leaks and spills.	Daily when in use
Machine Guards	Not Applicable	Check that all guards are in place and are secure before operation.	Daily when in use
Bottom Die	Not Applicable	Check for damage and build up of Galv and other foreign material. Remove any build up and replace any damaged tooling	Daily when in use
Forming Blade	Not Applicable	Check for damage and build up of Galv and other foreign material. Remove any build up and replace if damaged.	Daily when in use
Pneumatic Circuit	Not Applicable	Check cylinder for correct operation, security of mounting hardware, connections & pipe work for damage and/or leaks	Daily when in use
STR 750 Forming Machine	Not Applicable	Clean and Inspect the complete machine for signs of damage or excess wear, check security of fixings and guards etc.	Monthly

SECTION NUMBER

7

BASIC FAULT FINDING



BASIC FAULT FINDING INSTRUCTIONS.

FAULT	DIAGNOSIS	SOLUTION
Forming Blade Assembly operates in reverse when the foot pedal is pressed. Is driven upwards and not down.	Air hose connections from foot pedal incorrect	Swap connections at the foot pedal, then check for correct operation
Forming Blade Assembly does not operate at all when the foot pedal is pressed	<ol style="list-style-type: none"> 1 Air hose connections from the foot pedal to the cylinder not made 2 Main air in connection not made 3 Air compressor not turned on 	<p>Make the required connections, then check for correct operation</p> <p>Make the required connection, then check for correct operation</p> <p>Turn on the air compressor, then check for correct operation</p>
Pneumatic Cylinder is slow or stops part way of its stroke	<ol style="list-style-type: none"> 1 Air compressor regulator set too low 2 Air hoses from the foot pedal to the cylinder loose on their connection and/or damaged (leaking) 3 Faulty seals in the pneumatic cylinder 	<p>Adjust regulator for correct pressure, then check for correct operation</p> <p>Investigate, secure and/or replace</p> <p>Change the Pneumatic Cylinder</p>
When creasing, depth of crease too much or too little	Crease depth adjustment incorrect for size and gauge of material being formed	Adjust the depth of the crease via the knurled knob in the end of the forming head assembly (Cylinder End)

SECTION NUMBER

8

MACHINE ASSEMBLY DRAWINGS & PARTS LIST



SQUARE TO ROUND DUCT FORMING MACHINE (STR 750) ASSEMBLY DRAWINGS AND PARTS LIST.

INTRODUCTION.

This section of the user manual contains the necessary information to help with the continued safe use and maintenance of the **STR 750**.

One of the prime uses of this section of the manual is to help to expedite the process of obtaining replacements for worn or damaged components.

By using the appropriate assembly drawings, maintenance personnel are able to locate and identify the required part and via the individual ballooned item obtain the appropriate item part number from the accompanying parts list.

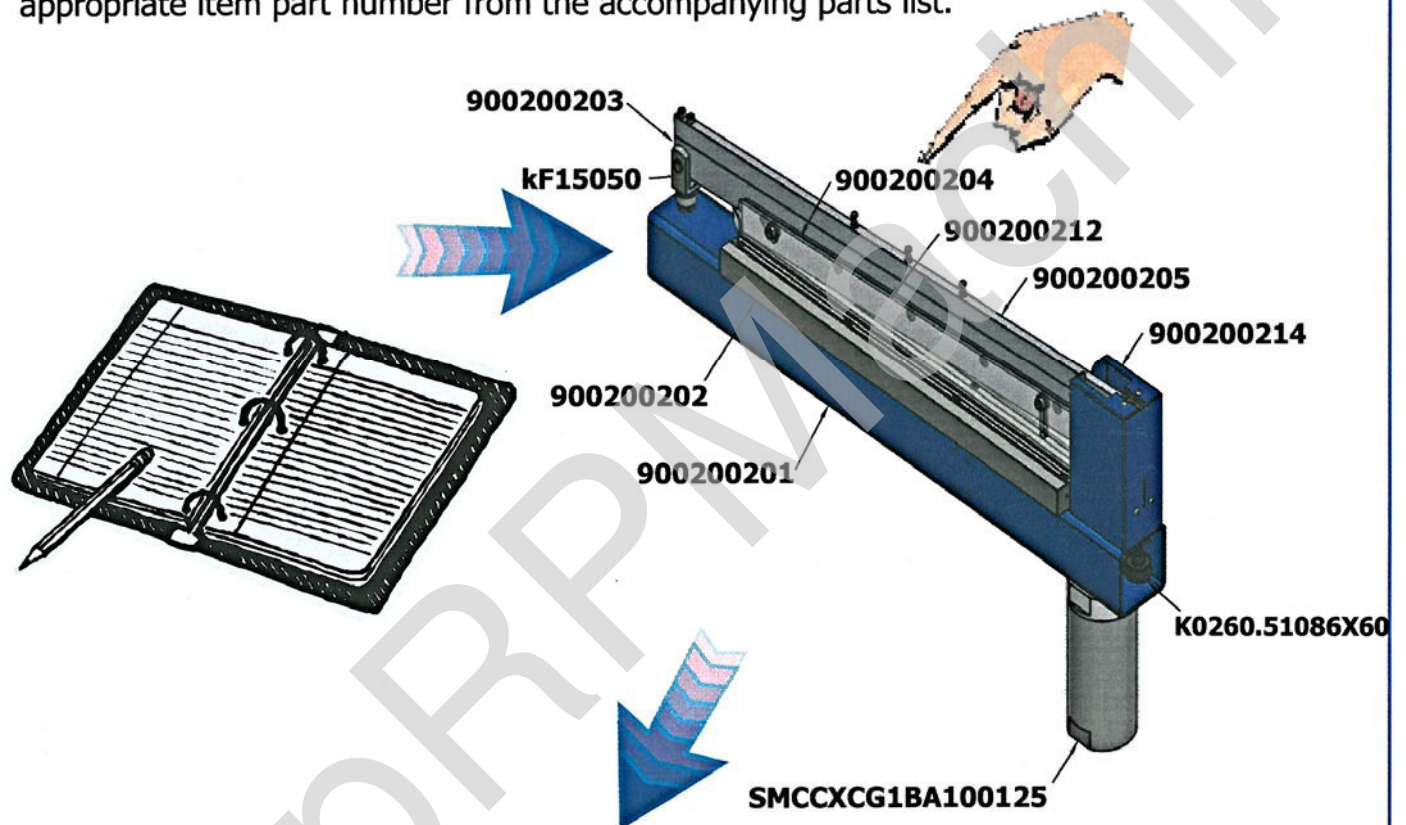

PART NUMBER	DESCRIPTION	QTY
900200201	Bottom Die Mounting Frame	1
900200202	Bottom Die	2
900200203	Forming Blade Holder	1
900200204	Forming Blade	1
900200205	Forming Blade Stiffener	1

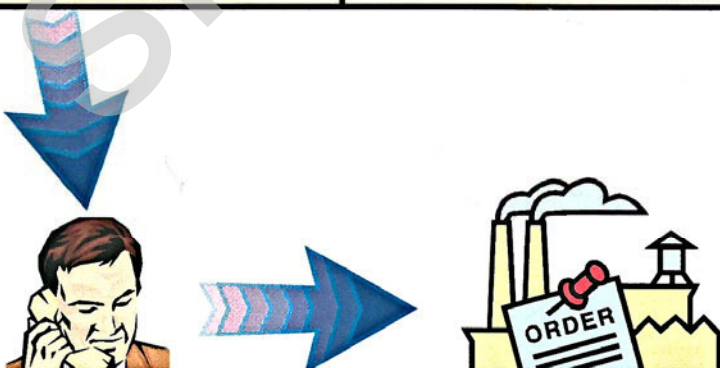

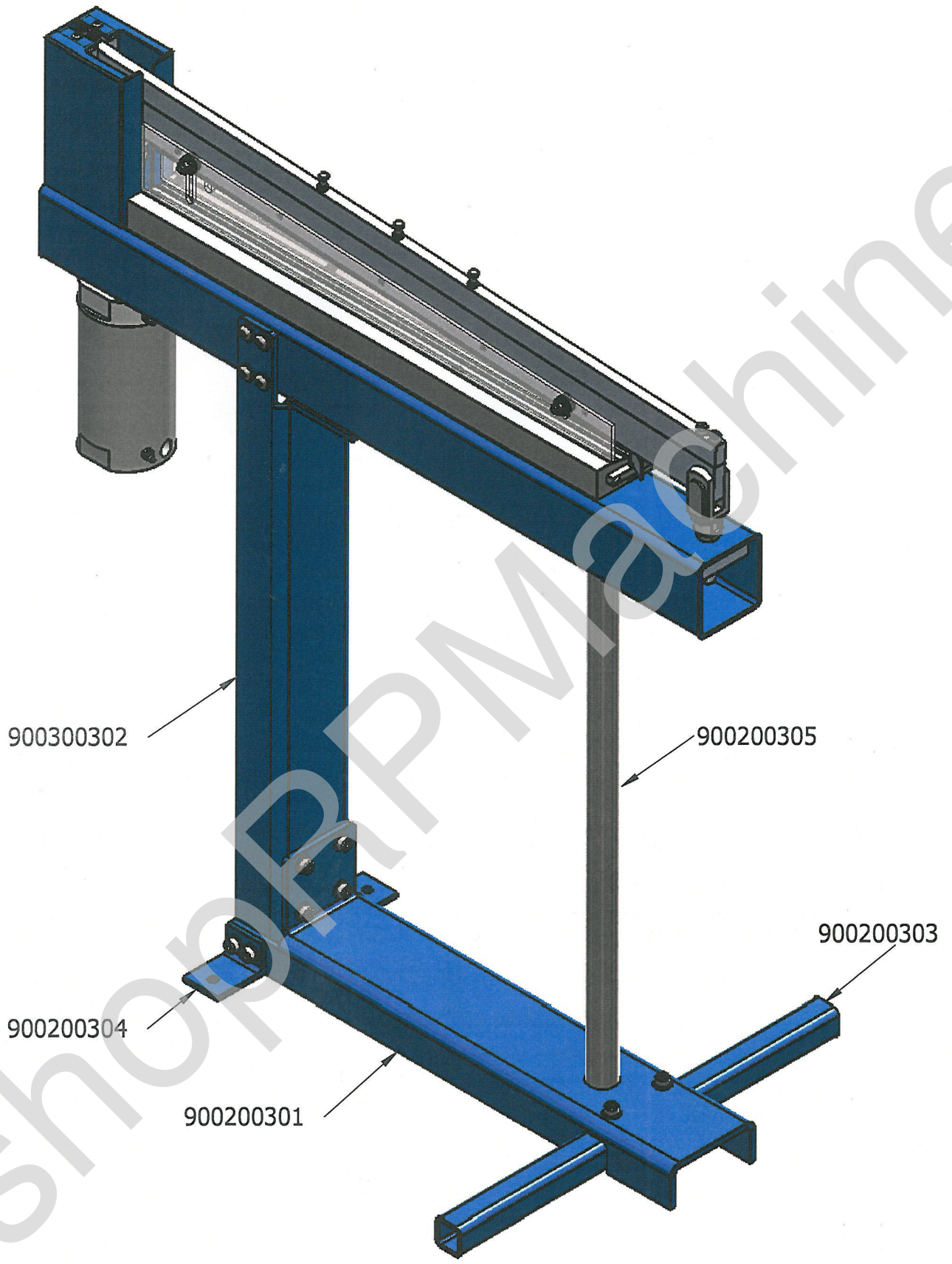

STR 750 GENERAL ASSEMBLY.

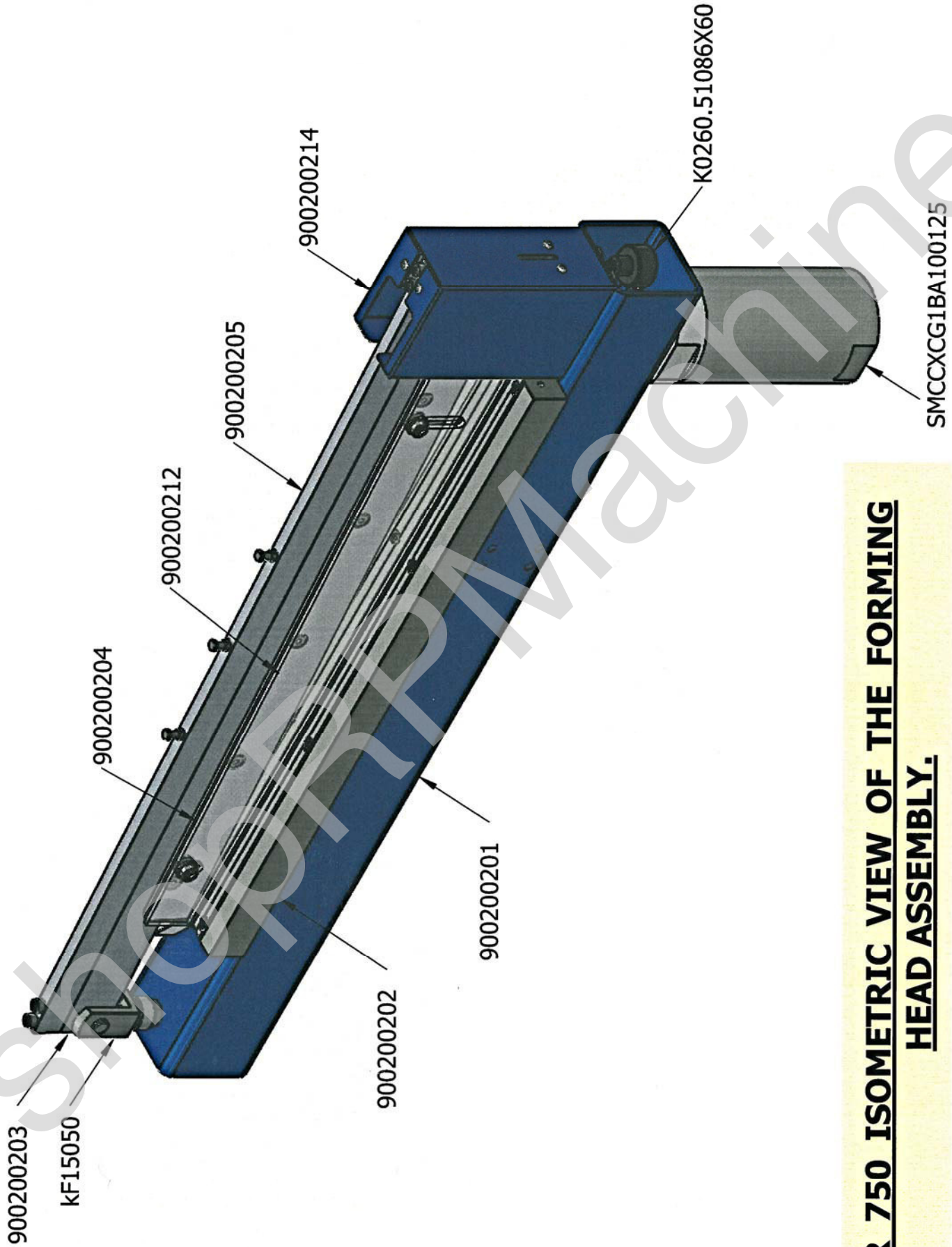

STR 750 ISOMETRIC VIEW OF THE FORMING HEAD ASSEMBLY.



M16x1.5
HALF-NUT

900200213

900200206

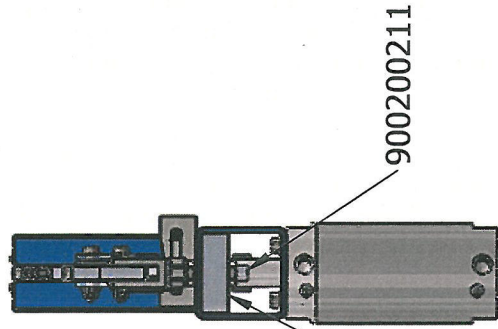

900200210

900200211

STR 750 SIDE AND END VIEWS OF THE FORMING HEAD ASSEMBLY.

SQUARE TO ROUND DUCT FORMING MACHINE (STR 750)
PARTS LIST.

Part No	Description	Qty
9002-002-01	Bottom Die Mounting Fame	1
9002-002-02	Bottom Die	2
9002-002-03	Top Blade Holder	1
9002-002-04	Forming Blade	1
9002-002-05	Top Blade Stiffener	1
9002-002-06	Pivot Pin Holder	1
9002-002-07	Guide Bar A	1
9002-002-08	Guide Bar B	1
9002-002-09	Jacking Block	1
9002-002-10	Box Section Stiffening Block	1
9002-002-11	Clevis Stud	1
9002-002-12	Blade Guard	2
9002-002-13	Locating Fin	1
9002-002-14	Cylinder Guard	1
9002-003-01	Base Frame Part 1	1
9002-003-02	Base Frame Part 2	1
9002-003-03	Stabilising Foot	1
9002-003-04	Angle Foot Bracket	2
9002-003-05	Stiffening Leg	1

SECTION NUMBER

9

RECOMMENDED SPARES LISTING



ShopRPM Machine